

TECHNICAL MANUAL

OPERATOR'S, AVIATION UNIT, AND

INTERMEDIATE

MAINTENANCE MANUAL

INCLUDING

REPAIR PARTS AND SPECIAL TOOLS LIST

FOR

AIRCRAFT WEIGHING KIT

TYPE A/S 37M -1

NSN 6670-00-148-9395

* This manual supersedes TM 55-6670-201-14, dated October 1974, including all changes.

HEADQUARTERS DEPARTMENT OF THE ARMY
17 JUNE 1985

CHANGE

NO. 2

HEADQUARTERS
DEPARTMENT OF THE ARMY
WASHINGTON, D. C., 28 May 1993

Operator's, Aviation Unit and Intermediate
Maintenance Manual
Including
Repair Parts and Special Tools List
for
AIRCRAFT WEIGHING KIT
TYPE A/S 37M-1
NSN 6670-00-148-9395

DISTRIBUTION STATEMENT A: Approved for public release distribution is unlimited

TM 55-6670-201-13&P, 17 June 1985, is changed as follows:

1. Remove and insert pages as indicated below. New or changed text material is indicated by a vertical bar in the margin. An illustration change is indicated by a miniature pointing hand.

Remove pages

i and ii
1-1 and 1-2
3-13 and 3-14
4-85/(4-86 blank)
A-1/(A-2 blank)
C-15 through C-18

Insert pages

i and ii
1-1 and 1-2
3-13 and 3-14
4-85/(4-86 blank)
A-1/(A-2 blank)
C-15 through C-18

2. Retain this sheet in front of manual for reference purposes.

By Order of the Secretary of the Army

GORDON R. SULLIVAN
General, United States Army
Chief of Staff

Official:

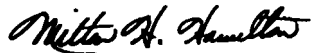

MILTON H. HAMILTON
**Administrative Assistant to the
Secretary of the Army**

04384

DISTRIBUTION

To be distributed in accordance with DA Form 12-31-E, block no. 2019, requirements for
TM 55-6670-201-13&P.

CHANGE }
NO. 1 }

HEADQUARTERS
DEPARTMENT OF THE ARMY
WASHINGTON, D.C., 8 December 1987

OPERATOR'S, AVIATION UNIT AND
INTERMEDIATE MAINTENANCE MANUAL
INCLUDING
REPAIR PARTS AND SPECIAL TOOLS LIST
FOR
AIRCRAFT WEIGHING KIT
TYPE A/S 37M-1
NSN 6670-00-148-9395

TM 55-6670-201-13&P, 17 June 1985, is changes as follows:

1. Remove and insert pages as indicated below. New or changed text material is indicated by a vertical bar in the margin. An illustration change is indicated by a miniature pointing hand.

Remove pages	Insert pages
1-1 through 1-4	1-1 through 1-4
1-9 and 1-10	1-9 and 1-10
2-5 through 2-8	2-5 through 2-8
4-1 and 4-2	4-1 and 4-2
A-1/A-2	A-1/A-2
B-3 and B-4	B-3 and B-4
- - -	B-4.1/B-4.2

2. Retain this sheet in front of manual for reference purposes.

By Order of the Secretary of the Army:

CARL E. VUONO
General, United States Army
Chief of Staff

Official:

R. L. DILWORTH
Brigadier General, United States Army
The Adjutant General

DISTRIBUTION:

To be distributed in accordance with DA 12-31, AVUM and AVIM Maintenance requirements for All Fixed and Rotary Wing Aircraft.



WARNING

HIGH VOLTAGE

is used in the operation of this equipment

DEATH ON CONTACT

may result if personnel fail to observe safety precautions.

Learn the areas containing high voltage in each piece of equipment.

Be careful not to contact high-voltage connections when installing
or operating this equipment.

Before working inside the equipment, turn power off and ground points
of high potential before touching them.

Use caution when operating around unguarded 115 Vac energized circuits.

For Artificial Respiration, refer to FM 21-11.

WARNING

TOXIC AND FLAMMABLE CHEMICALS

When you use solvents, be sure that the place you work in is well ventilated, **WEAR GLOVES AND EYE PROTECTION**. If you don't have good ventilation, read TB MED 223 and use the recommended respiratory (breathing) protection as directed by your servicing medical activity.

DON'T USE FLAMMABLE SOLVENTS AROUND HEAT, OPEN FLAME, OR SPARKS.

IF YOU GET SOLVENT IN YOUR EYES OR ON YOUR SKIN, FLUSH THE CHEMICAL AWAY WITH WATER FOR 15 MINUTES; THEN GET MEDICAL HELP.

**OPERATOR'S, AVIATION UNIT, AND
INTERMEDIATE MAINTENANCE MANUAL
INCLUDING
REPAIR PARTS AND SPECIAL TOOLS LIST
FOR
AIRCRAFT WEIGHING KIT
TYPE A/S 37M-1
NSN 6670-00-148-9395**

REPORTING ERRORS AND RECOMMENDING IMPROVEMENTS

You can help improve this manual. If you find any mistakes or if you know of a way to improve the procedures, please let us know. Mail your letter or DA Form 2028 (Recommended Changes to Publications and Blank Forms), or DA Form 2028-2 located in the back of this manual directly to: US Army Aviation and Troop Command, ATTN: AMSAT-I-MP, 4300 Goodfellow Blvd., St. Louis, MO 63120-1798. A reply will be furnished to you.

DISTRIBUTION STATEMENT A: Approved for public release; distribution is unlimited

TABLE OF CONTENTS

CHAPTER 1	INTRODUCTION	1-1
Section I	General Information	1-1
Section II	Equipment Description and Data	1-3
Section III	Technical Principles of Operation	1-9
CHAPTER 2	OPERATING INSTRUCTIONS	2-1
Section I	Description and Use of Operator's Controls and Indicators	2-1
Section II	Operator Preventive Maintenance Checks and Services	2-9
Section III	Operation Under Usual Conditions	2-10
Section IV	Operation Under Unusual Conditions	2-10

	Page	
CHAPTER 3	AVIATION UNIT MAINTENANCE (AVUM)-MAINTENANCE INSTRUCTIONS	3-1
Section I	Repair Parts, Special Tools, TMDE, and Support Equipment.	3-1
Section II	Service Upon Receipt	3-1
Section III	Preventive Maintenance Checks and Services (PMCS).	3-2
Section IV	Troubleshooting.	3-6
Section V	Maintenance Procedures	3-9
CHAPTER 4	AVIATION INTERMEDIATE MAINTENANCE (AVIM) - MAINTENANCE INSTRUCTIONS	4-1
Section I	Repair Parts, Special Tools, TMDE, and Support Equipment.	4-1
Section II	Service Upon Receipt.	4-2
Section III	Preventive Maintenance Checks and Services (PMCS).	4-2
Section IV	Troubleshooting.	4-10
Section V	Maintenance Procedures	4-36
Section VI	Preparation for Storage or Shipment.	4-85
Appendix A	REFERENCES.	A-1
Appendix B	MAINTENANCE ALLOCATION CHART (MAC)	B-1
Appendix C	REPAIR PARTS AND SPECIAL TOOLS LIST.	C-1
Section I	Introduction.	C-1
Section II	Repair Parts List.	C-6
Group 00	Aircraft Weighing Kit.	C-6
Group 01	Accessory Kit.	C-8
Group 02	Electronic Weighing Indicator.	C-10
Group 03	Amplifier/Oscillator Printed Circuit Card.	C-12
Group 04	Cable Assemblies, Cells, Weighing Accessories.	C-15
Section III	Tool and Test Equipment Requirements	C-17
Section IV	NSN Part Number Index.	C-18
Appendix D	EXPENDABLE SUPPLIES.	D-1
Glossary	G-1
Alphabetical Index	I-1
Foldouts	FO-1

HOW TO USE THIS MANUAL

This manual has 4 chapters, 4 appendixes, a glossary, an alphabetical index, and three fold-outs.

1. Chapter 1 contains general information, equipment description and data, and technical principles of operation.
2. Chapter 2 contains operating instructions, use of controls and indicators, preventative maintenance checks and services, and operation under usual conditions.
3. Chapters 3 and 4 contain maintenance procedures at AVUM and AVIM levels.
4. The appendixes contain general reference information.

HOW TO FIND WHAT YOU NEED

1. Troubleshooting - Refer to Chapters 3 and 4
2. Operational Test - Refer to Chapters 3 and 4
3. Schematic Diagram - FO-2
4. Inspections - Refer to Chapters 2, 3, and 4
5. Maintenance - Refer to Chapters 3 and 4. To find a task use the index in the back of this manual.

- a. Each task is listed under the name of the component that it applies to.

Example:

	<u>TASK</u>	<u>PAGE</u>
INDICATOR COVER REMOVAL/ INSTALL	4	3-9
FUSE REMOVAL/REPLACEMENT	5	3-11
AC AND DC POWER CABLE INSPECTION/REPLACEMENT	6	3-13

HOW TO USE THE TASK

1. Preparation: Each task begins with initial set-up information. Read it carefully before starting. It tells what you will need and what you have to know to do the job.

<u>APPLICABLE CONFIGURATION</u> -	Tells what configuration the task applies to.
<u>TOOLS/TEST AND SUPPORT EQUIPMENT</u> -	If any tools from a tool kit are needed, the tool kit is listed. If two of the same tools are required and the tool kit includes only one, the additional tool required is listed. Tools needed that are not in the kit are called out by name. Tools, containers, and special test equipment are listed in table 1-2.
<u>MATERIALS</u> -	Lists bulk items such as solder, cloth, packing, and the like may be necessary to service or protect equipment.
<u>PARTS</u> -	Lists parts required or refers reader to Appendix C, RPSTL.
<u>PERSONNEL REQUIRED</u> -	Each MOS needed to do the task is listed. When more than one of any MOS is needed, the number is shown in parenthesis.
<u>REFERENCES</u> -	Lists the figures that support installation or assembly of components. Also lists related tasks or paragraphs that are referenced in task steps.
<u>EQUIPMENT CONDITION</u> -	Procedures that will be performed before starting the task are listed. Install tasks and assembly tasks are not normally listed in equipment condition.
<u>GENERAL SAFETY INSTRUCTIONS</u> -	Provides safety precautions that must be observed throughout tasks. Warnings include basic first aid instructions.
<u>LOCATOR FIGURE</u>	The area of the indicator where the task will be performed is shown, with components to be worked on called out.

2. Example:

3-17. FUSE REMOVAL/REPLACEMENT.

3-17

Initial Set-up:

APPLICABLE CONFIGURATION:

Aircraft Weighing Kit, Type A/S 37M-1

TOOLS/TEST AND SUPPORT EQUIPMENT:

Tool Kit: Electrical Repairer:
Army Aircraft, NSN 5180-00-323-4915.

PARTS :

Fuses: 1/2A, 1/4A, as required.

PERSONNEL REQUIRED:

68F Aircraft Electrician

REFERENCES:

3-12. TASK 1 NULL METER FUNCTION CHECK.
3-16. TASK 4 INDICATOR COVER REMOVAL/
INSTALL.
Appendix C, Figure C-3.

EQUIPMENT CONDITION:

Power disconnected. Kit on workbench,
cover open; indicator cover removed
from indicator housing.

Performance:

- a. Before starting, read the entire task. Familiarize yourself with the entire procedure before beginning the task.
- b. As you read, pay attention to WARNINGS, CAUTIONS, and NOTES.
- c. A glossary follows Appendix D. It lists the special words and terms used in this manual and gives their meanings.

CHAPTER 1 INTRODUCTION

SECTION I - GENERAL INFORMATION

1-1. SCOPE.

1-1

a. This manual includes operation and maintenance instructions for the Aircraft Weighing Kit, Type A/S 37M-1 (Revere Part Numbers C-55800-3-50, 155800-03) illustrated below.

b. The Aircraft Weighing Kit is a complete, portable system that is used to measure individual force reactions exerted on three hermetically-sealed/weight-sensing cells called load cells. This weight data is used to determine the gross weight and center of gravity of an aircraft.

c. The Aircraft Weighing Kit is capable of weighing up to 50,000 pounds on each load cell, or a maximum total of 150,000 pounds for the three load cells. When the aircraft is properly leveled, and other operating instructions are followed, the Aircraft Weighing Kit accuracy is within $\pm 0.1\%$ of the applied load, or ten pounds, whichever is greater.

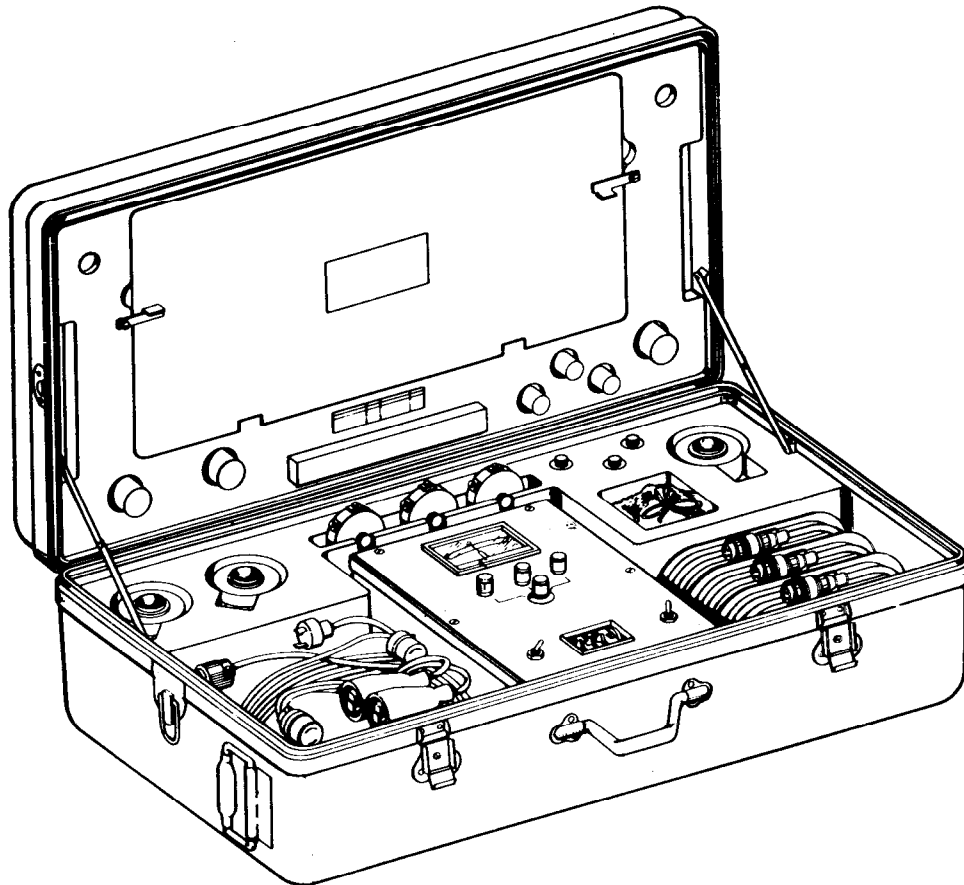

1-2. MAINTENANCE FORMS, RECORDS, AND REPORTS.

1-2

Department of the Army forms and procedures used for equipment maintenance will be those prescribed by DA PAM 738-751, Functional Users Manual for The Army Maintenance Management System-Aviation (TAMMS-A).

1-3. DESTRUCTION OF ARMY MATERIEL TO PREVENT ENEMY USE.

1-3

Refer to TM 750-244-1-4, Electronic materiel, Procedures for Destruction to Prevent Enemy Use.

1-4. PREPARATION FOR STORAGE OR SHIPMENT.

1-4

For storage and shipment information, refer to Chapters 3 and 4.

1-5. REPORTING EQUIPMENT IMPROVEMENT RECOMMENDATIONS (EIR).

1-5

If your Aircraft Weighing Kit needs improvement, let us know. Send us an EIR. You, the user, are the only one who can tell us what you don't like about our equipment. Let us know why you don't like the design or performance. Put it on an SF 368 (Product Quality Deficiency Report). Mail it to: U.S. Army Aviation and Troop Command, ATTN: AMSAT-I-MDO, 4300 Goodfellow Boulevard, St. Louis, MO, 63120-1798. A reply will be furnished directly to you.

SECTION II - EQUIPMENT DESCRIPTION AND DATA

1-6. EQUIPMENT CHARACTERISTICS, CAPABILITIES, AND FEATURES.

1-6

a. Function.

- (1) General. The Aircraft Electronic Weighing Kit is a null balance system, that compares a primary voltage developed within the indicator with a voltage developed by each load cell.
- (2) Load Cell. The load cell is a transducer that converts mechanical forces into electrical voltages. This process results from the fact that a steel column deforms when a force is applied along the axis of the column. The deformation due to compressive loads is proportional to the force applied. In the transducer, resistance strain gages are bonded to a steel column. When the column compresses under load, the strain gages change their electrical resistance. When the load is removed, the resistance returns to normal. A known input voltage is applied to a Wheatstone bridge circuit consisting of the strain gages, as illustrated; thus, changes in force are converted to an electrical output voltage that is proportional to the force applied.

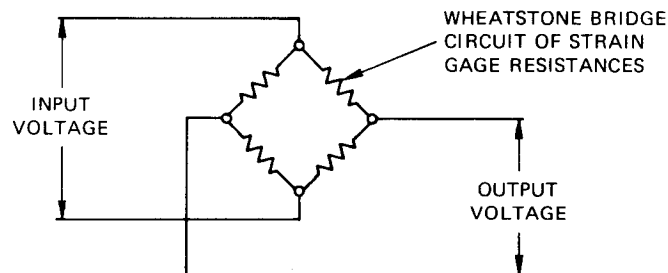

Simplified Load Cell Schematic

- (3) Electronic Weighing Indicator. The electronic weighing indicator contains a meter that acts as a galvanometers to give a centered, or null indication when the voltage from a load cell is balanced with the output from the indicator calibrating network. The calibrating network voltage is changed by adjusting the indicator POUNDS switch. The POUNDS switch contains four thumbwheel switches, which when positioned to a weight indication, produce a voltage proportional to that weight. Thus, when the indicator meter is nulled or balanced, the two voltages are equal and the weight applied to the load cell can be determined by directly reading the POUNDS switch setting. The output from each of the three load cells is applied to the indicator separately, and the total weight of the aircraft is determined by summing the values for each load cell.

1-6. EQUIPMENT CHARACTERISTICS, CAPABILITIES, AND FEATURES. (Cont)

b. Leading Particulars. The leading particulars to the Aircraft Weighing Kit are listed in Table 1-1.

Table 1-1. Leading Particulars

Characteristic	Description
Dimensions	
Depth	17.50 inches
Width	32.88 inches
Height	8.75 inches
Weight (complete with accessory kit)	72 pounds
Voltage input AC	100-130 Vat, 60 Hz, single phase
Voltage input DC	22-28 Vdc
Usable temperature range	(32°F to 120°F)
Power consumption AC DC	AC - 11-1/2 W, DC - 4 W
Load capacity (maximum)	150,000 pounds. 50,000 pounds per load cell.
Accuracy (design)	$\pm 0.1\%$ of applied load or 10 pounds, whichever is greater.
Zero adjustment	± 2000 pounds minimum for each load cell.
Meter sensitivity	210 pounds or less (meter swing from null to green area).
Load Cells	
Excitation, electrical, Volts	Function of instrument 4 Vac (approx)
Terminal resistance, input (ohms)	530 ohms $\pm 10\%$
Load cell output resistance (ohms)	460-500 ohms
Zero balance (% of rated output)	Less than 4% of cell full scale capability.

NOTE:



Accuracy is verified to 0.25% of Applied Load or 25lbs, whichever is greater (Limitation of Calibration Standards).

1-6. EQUIPMENT CHARACTERISTICS, CAPABILITIES, AND FEATURES. (Cont)

1-6

Table 1-1. Leading Particulars (Cont.)

Characteristic	Description
Insulation resistance (megohms)	
bridge to ground	greater than 5,000 Megohms
shield to ground	greater than 5,000 Megohms
bridge to shield	greater than 5,000 Megohms
Indicator resolution	Function of instrument (greater than 10,000 counts)

c. Test Equipment Features. Refer to Table 1-2 for test equipment characteristics.

Table 1-2. Test Equipment Characteristics/Features

Item	Characteristics/Features
AC Power Supply	Adjustable, 100-135 Vac, 60 Hz
DC Power Supply	Adjustable, 22-28 Vdc
Oscilloscope	Triggerable, dual beam, 500 kc minimum bandwidth
Multimeter	AN/PSM-45, or equivalent
Load Cell Simulator	Revere Model R941, or equivalent
Adapter Cable	Adapter cable for load cell to simulator connection: Connector number GS02-14S-5P-001 attached to four 8" color-coded wires
Pliers, Strain Relief Bushing	Heyco No. 29

1-7. LOCATION AND DESCRIPTION OF MAJOR COMPONENTS.

a. General. The equipment furnished with the Aircraft Weighing Kit is shown in the accompanying illustration.

b. Case Assembly. The complete kit is housed in a fiberglass case assembly (1). During operation, the shock-mounted electronic weighing indicator (2) remains in the case assembly, while the load cells (3), cables (4, 5, 6, 7, and 8), adapters (9, 10, 11, and 12), and accessory kit (13) are removed as required.

c. Electronic Weighing Indicator. The electronic weighing indicator (2) is a complete unit that can be operated and monitored without removal from the case assembly. All controls, power connection receptacles, and fuses are located on the indicator.

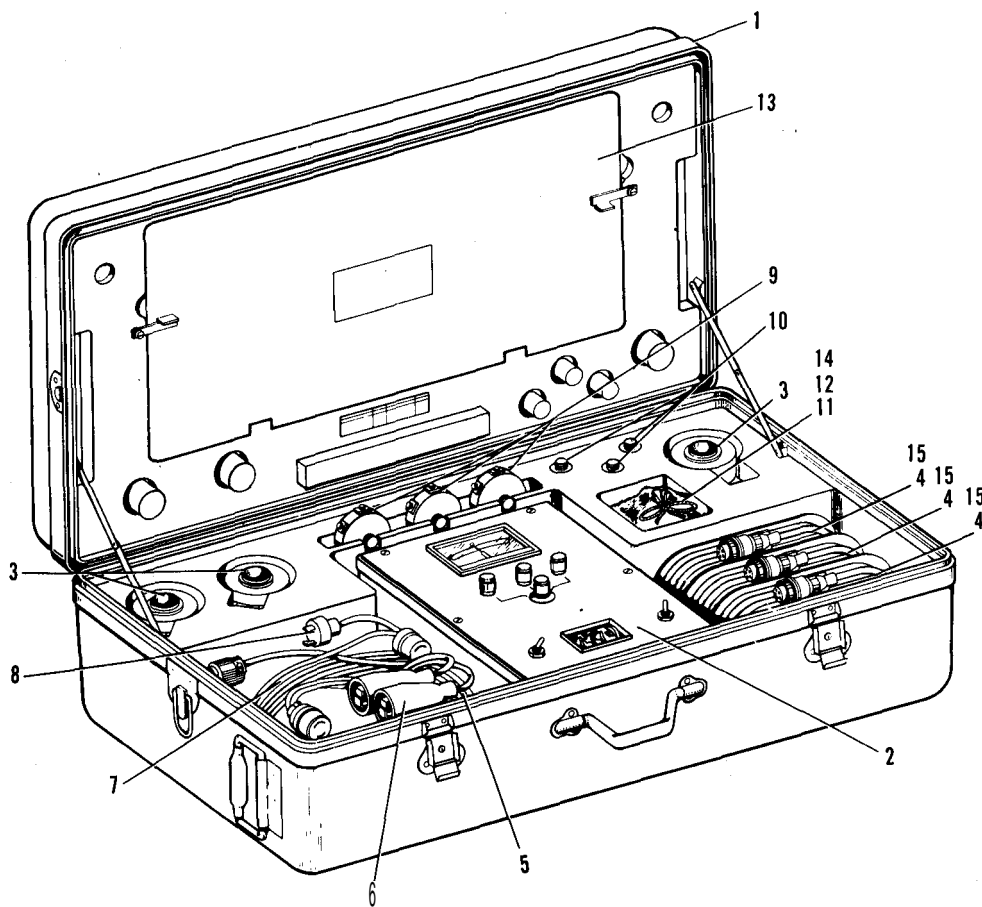

- | | | |
|----------------------------------|---------------------------------|---------------------------|
| 1. Case Assembly | 6. Battery Extension Cable (1') | 11. Spherical Adapter (3) |
| 2. Electronic Weighing Indicator | 7. DC Cable (15') | 12. Pipe Type Adapter (2) |
| 3. Load Cell Assembly (3) | 8. AC Cable (25') | 13. Accessory Kit |
| 4. Load Cell Cable (50') (3) | 9. Ring Adapter (3) | 14. Allen Wrench (2) |
| 5. Adapter Cable (2') | 10. Plug Adapter (3) | 15. Reel Assembly (3) |

1-7. LOCATION AND DESCRIPTION OF MAJOR COMPONENTS. (Cont)

1-7

d. Load Cells. The Aircraft Weighing Kit contains three hermetically-sealed load cells (3) of 50,000-pound capacity each. The load cells, while similar in appearance, are not electrically interchangeable; thus, each load cell must be matched to its corresponding color-coded load cell cable. An electrical receptacle is located on the side of each cell that mates with a 50-foot cable which in turn connects each cell to the indicator.

e. Adapter. Adapters (9, 10, 11, and 12) and Allen wrenches (14) are provided to adapt the load cells for various mounting arrangements. Each load cell has a threaded hole on the bottom to receive either a plug or a ring adapter that will mate with an aircraft lifting jack. The top of the cell is shaped to receive spherical adapters that are designed to mate with aircraft jack pads or aircraft axles.

f. Cables. Three dc power cables of different length are furnished for connection to a 24-Vdc power source. One cable (5) is a short two-conductor adapter, two-feet long, with a female plug at one end to connect to the indicator assembly and a male plug on the other end to connect to the 15-foot cable (7). The 15-foot cable is also a two-conductor cable with a female plug to connect to the adapter cable or the indicator and a male plug to connect to the dc power source. The positive (+) and negative (-) plug connections are shaped differently to ensure correct polarity. The third cable (6) is a one-foot long, two-conductor, battery extension cable with a female plug at one end and color-coded battery clips at the other end. A single, three-conductor, ac power cable (8), 25-foot long, is supplied with grounded ac male and female plugs on opposite ends. Three four-conductor, shielded, 50-foot load-cell cables (4) are supplied. The cables are terminated with plugs at one end to mate with the load-cell receptacle, and soldered at the other end inside the indicator assembly. When not in use, the load-cell cables are wound on reels (15) located in the case assembly.

1-7. LOCATION AND DESCRIPTION OF MAJOR COMPONENTS. (Cont)

g. Accessory Kit. The accessory kit, accompanying illustration, is a self-contained unit that is mounted in the weighing kit cover. Individual components of the accessory kit are used in conjunction with the weighing kit when determining the gross weight and center of gravity (cg) of an aircraft.

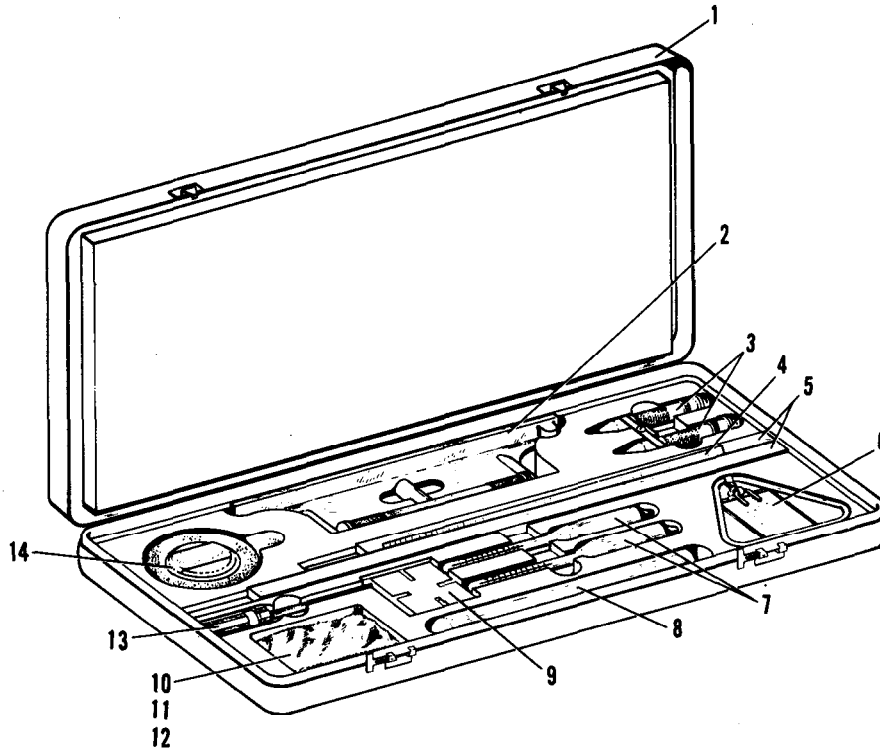

- | | | |
|------------------|-------------------------|-----------------|
| 1. Case Assembly | 6. Fuel Dipper | 11. Chalk |
| 2. Level | 7. Hydrometer (2) | 12. Chalk Line |
| 3. Plumb Bob (2) | 8. Hydrometer Jar | 13. Screwdriver |
| 4. Rule | 9. Hydrometer Jar Stand | 14. Tape |
| 5. Leveling Bar | 10. Bag | |

1-8. DIFFERENCES BETWEEN MODELS.

This manual covers all A/S 37M-1 Aircraft Weighing Kits. However, a single variation exists through a January 1982 addition of RFI shields and EMI filters at power and load cell cable terminations on the electronic weighing indicator. While not essential to kit operation, the shields and filters reduce interference in areas of disturbance, which might result from nearby power line noise or airport control tower operations. Further, in January 1983 a change in the configuration of filters FL3, FL4, and FL5 on power cable connections necessitated modification in the RFI shield on which the filters are mounted. When replacing filters in kits with a - serial number between 5740A and 5894A, replace all filters and the RFI shield as a matched set.

SECTION III - TECHNICAL PRINCIPLES OF OPERATION

1-9. FUNCTIONAL DESCRIPTION.

1-9

a. The purpose of the Aircraft Weighing Kit is to determine the gross weight and center of gravity of an aircraft. Normal procedures for preparing the aircraft for weighing should be used. Refer to the applicable TM for the type of aircraft being weighed. Comply with each maintenance procedure as outlined in the aircraft TM and in TM 55-1500-342-23 Weight and Balance Manual, Before proceeding. The components in the Aircraft Weighing Kit -Accessory Kit are to be used as described in TM 55-1500-342-23 to perform the pre-weighing tasks. The accompanying illustration (items 1 through 9) shows a typical Aircraft Weighing Kit installation. The functional description of items 1 through 9 is given on page 1-10.

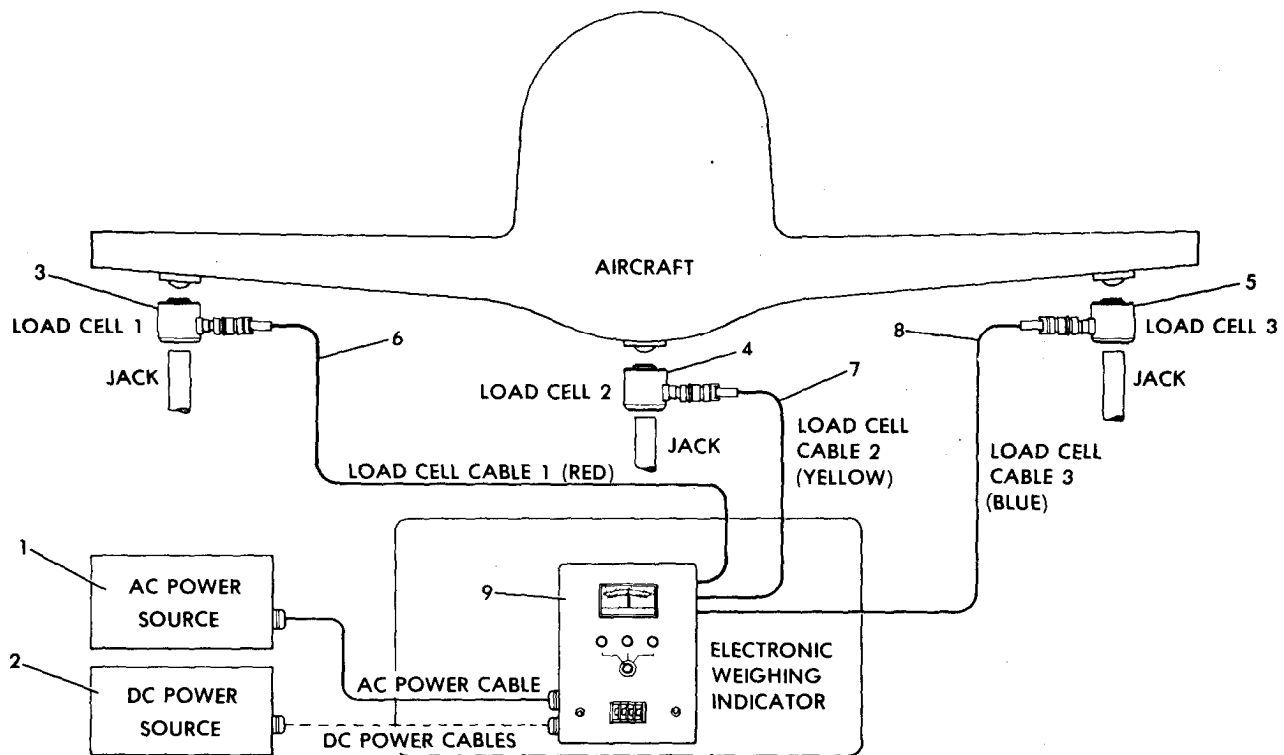

1-9. FUNCTIONAL DESCRIPTION. (Cont)

1-9

b. Aircraft Weighing Kit Major Components Functional Diagram

- (1) AC Power Source and Cable (25-foot). Provides power to system.
- (2) DC Power Source and Cable (15-foot), adapter cable (2-foot), and battery cable. Provides alternate power to system.
- (3) Load Cell 1. Provides an electrical signal equivalent to aircraft weight for a single support point.
- (4) Load Cell 2. Provides an electrical signal equivalent to aircraft weight for a single support point.
- (5) Load Cell 3. Provides an electrical signal equivalent to aircraft weight for a single support point.
- (6) Load Cell 1 Cable. Transmits input voltage from electronic weighing indicator to load cell and differential voltage from load cell to indicator when weight is applied to load cell.
- (7) Load Cell 2 Cable. Transmits input voltage from electronic weighing indicator to load cell and differential voltage from load cell to indicator when weight is applied to load cell.
- (8) Load Cell 3 Cable. Transmits input voltage from electronic weighing indicator to load cell and differential voltage from load cell to indicator when weight is applied to load cell.
- (9) Electronic Weighing Indicator. Compares electrical signal from cell with signals in calibrating network to provide a reading in pounds.

1-10. GENERAL DESCRIPTION.

1-10

a. General. The Aircraft Weighing Kit is a null balance system that compares a primary voltage developed within the indicator with a voltage developed by each load cell. Indicator circuit function is illustrated on the overall block diagram. Components designated in GENERAL DESCRIPTION and PRINCIPLES OF OPERATION are shown in Figure FO-2, Aircraft Weighing Kit Schematic Diagram.

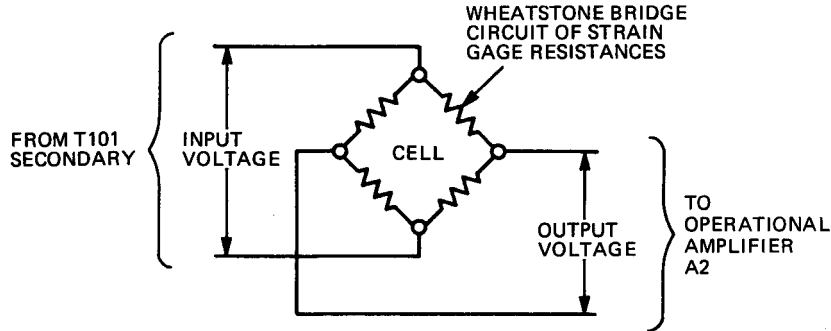

b. Load Cell. Each load cell contains four steel columns with resistance strain gages bonded to them. The resistances are connected together to form a Wheatstone bridge. When the weight of an aircraft is exerted on a load cell, the steel columns are compressed, and the strain gages react by changing resistance. A secondary winding on transformer T101 supplies a sine wave voltage to the resistance strain gages in the measuring bridge. Therefore, when a load cell is compressed and strain gages change resistance, load cell output voltage changes proportionally to the compression applied. Load cell output voltage goes to operational amplifier A2.

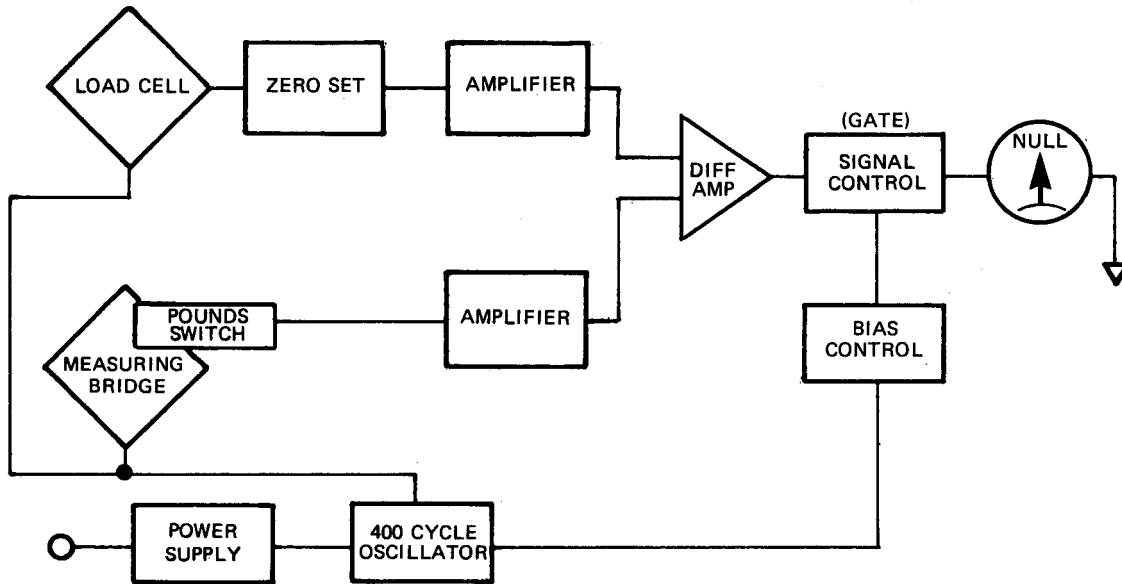

c. Measuring Bridge Circuitry. Transformer T101 also supplies an input voltage to the measuring bridge and the POUNDS switch. The POUNDS switch contains one thumbwheel switch and three thumbwheel potentiometers operating as a Kelvin-

1-10. GENERAL DESCRIPTION. (Cont)

1-10

Varley potentiometer. The thumbwheel switch (MSD) operates relays to introduce the resistance of the Kelvin-Varley potentiometer into the measuring bridge circuitry. When the thumbwheel controls are positioned to a weight indication, a voltage proportional to that weight is produced.

d. Input Amplifier and Differencing Amplifier. The output voltage from the selected load cell and the output voltage of the POUNDS switch are fed to an instrumentation amplifier that consists of operational amplifiers A2, A3, and A4. The two output voltages are compared. Any difference between the two signals appears at the output of A4. A difference between the two output voltages indicates that POUNDS switch setting (weight indication) is incorrect for the amount of weight exerted on the load cell. No difference voltage at the output of A4 indicates that the cell output voltage has been matched by the output voltage of the POUNDS switch. The weight indicated by the POUNDS switch will be the weight exerted on the load cell.

e. Output Control.

- (1) The output of operational amplifier A4 is fed to an output control circuit that consists of field-effect transistor Q2, diode D3, transistor Q3, and a secondary winding on transformer T101. The output of A4 is fed to transistor Q2. The gate of Q2 is controlled by Q3, which is switched on by positive peaks from T101. Thus, only a controlled portion of A4 output reaches resistor R61 and capacitor C13 to create a dc-level for meter M101.
- (2) The null meter, M101, indicator normally rests at mid-scale when not energized. During operation it is held in balance by the output of A4 through Q2. The indicator is driven to the left or right depending on whether the POUNDS switch output voltage is above or below the load cell output voltage level. When the POUNDS switch output voltage matches the load cell voltage output, the meter is in balance or at a null reading. The weight of the aircraft is obtained by reading the POUNDS switch readout for each cell and totalling the three readings.

f. Power Sources.

- (1) Three power sources operate the Aircraft Weighing Kit. External power source required is 22 to 28 Vdc or 115 Vac. If 115 Vac is selected to power the Aircraft Weighing Kit, transformer T2 and diodes D5 and D6, and capacitor C16 convert 115 Vac to 24 Vdc operating voltage.
- (2) The second power source, transistor Q1 and zener diode D4, provides a regulated 20 Vdc source. Operational amplifier A1 provides a source of mid-point voltage used as signal common.
- (3) The third power source, transistors Q6, Q4, and Q5, and transformer T101 provide sine wave voltages that power the load cells, the zero set circuitry, and the POUNDS switch, as well as transistor Q2 biasing circuitry.

1-11. PRINCIPLES OF OPERATION.

a. Load Cell.

- (1) Each load cell contains four steel columns with resistance strain gages bonded to them. All of the strain gages within each cell are wired together to form a Wheatstone bridge. Such an arrangement, when supplied with an input voltage (3-4 Vac), can produce accurate and easily detected changes in output voltage (8 mVac) for a full scale meter reading.

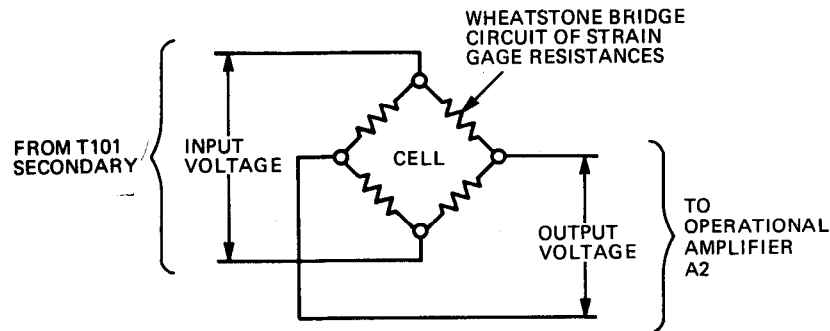

- (2) The sine wave voltage is supplied by a secondary winding of transformer T101. When a load cell is compressed by the weight of an aircraft, the strain gages change resistance. A change in strain gage resistance changes the output voltage proportionately to the amount of weight exerted on the steel columns.
- (3) Each load cell output voltage is selected and measured individually by operating CELL SELECTOR switch S101. The output voltage of the selected load cell goes to operational amplifier A2.
- (4) The zero set circuitry is required because of minor manufacturing variations in load cell zero output when no weight is present. The circuitry consists of resistors R9, R11, (with zero set control R101 in parallel), and R10 arranged as a voltage divider across the load cell bridge. The divider is powered by the same transformer T101 secondary sine wave as the load cell. Resistors R9 and R10 reduce the T101 sine wave to the millivolt level. Depending on which cell is selected by CELL SELECTOR switch, S101, zero set controls R101, R102, or R103 is adjusted to provide zero output with no load applied.

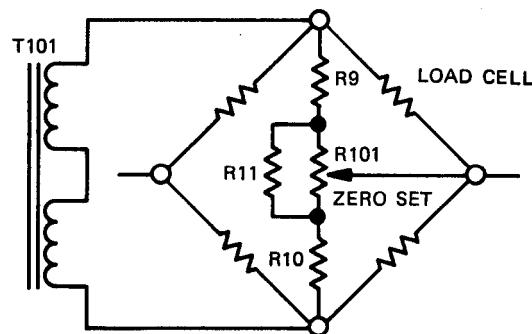

- (5) The phase potentiometers R1, R2, and R3 (along with capacitors C1, C2, and C3) recenter the mid-point of the load cell bridge to compensate for capacitance introduced by the individual cells and connecting cables.
- (6) The load cell span potentiometers R5, R6, and R7 are required to equalize cell outputs. Load cell output may vary from cell to cell; therefore, each cell is designed to produce more output than is needed. The span potentiometers are connected across each cell output to adjust the cells to the lowest cell output of the three.

b. Measuring Bridge

- (1) The sine wave input voltage that is applied to the load cell is supplied by transformer T101. The same winding on T101 also supplies a sine wave input voltage to the measuring bridge and related resistances but at 180° phase shift. Therefore, regulation of T101 is unnecessary.

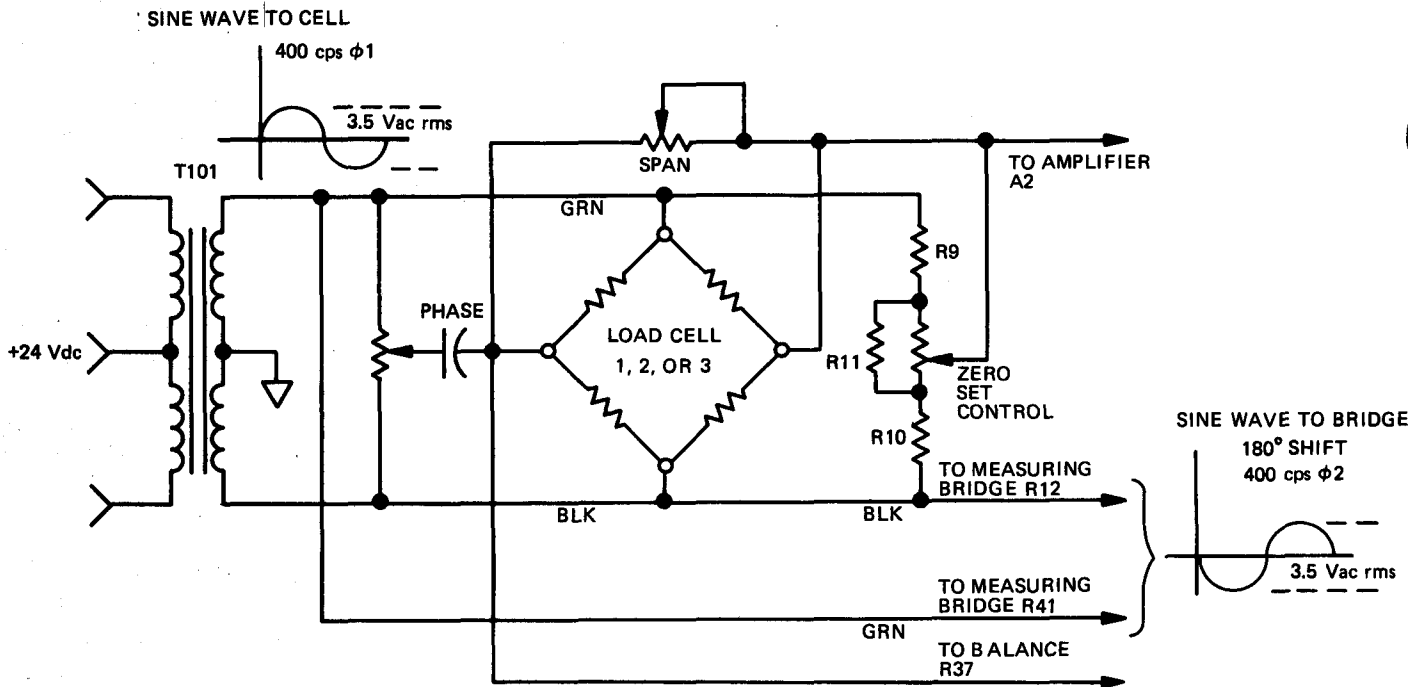

- (2) The input voltage (typically 3.5 Vac rms) is dropped to the millivolt level through resistors R12 and R41. As a bridge, the output voltage from the load cell appears at R37 between the left arms R35 and R39. An imbalance results and current flows until the resistances of the right arms R40 and the POUNDS switch is adjusted to restore balance to the bridge.

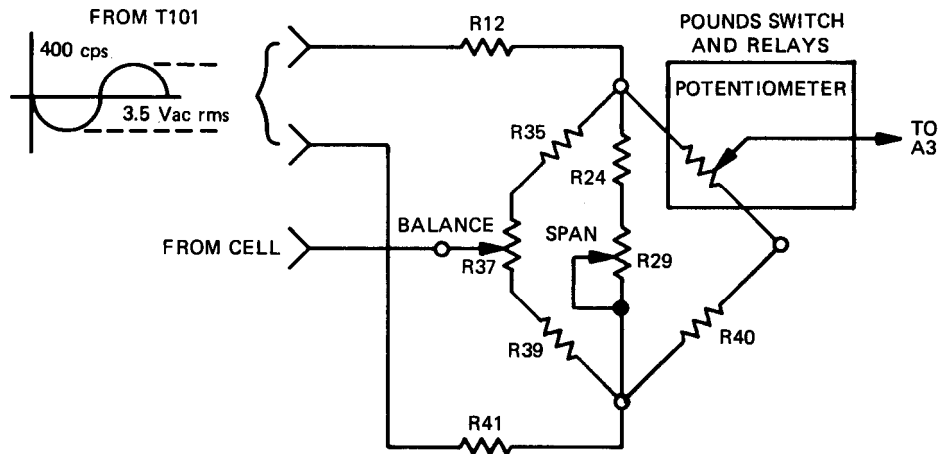

- (3) The balance potentiometer R37 is provided to adjust the measuring bridge output voltage. It is adjusted for zero output with the POUNDS switch set at 0-0-0-00, the zero set controls (R101, R102, and R103) set at exactly five turns from extreme counterclockwise, and the load cells producing zero output. Adjusting R37 for a state of balance in the bridge also eliminates minor amplifier offsets and circuit phase shifts. A state of balance in the bridge is indicated by null meter M101 reading at center.
- (4) POUNDS switch (Figure 1-1)
- (a) The POUNDS switch contains one thumbwheel switch and three thumbwheel potentiometers. The thumbwheel switch, which represents the most significant digit (MSD) on the POUNDS switch readout, operates low thermal emf, dual contact relays that remove resistance (10,000-pound increments) and introduce the POUNDS switch resistance. The POUNDS switch is a Kelvin-Varley potentiometer that provides a constant input impedance throughout the range of thumbwheel adjustments.
 - (b) A -(minus) position on the MSD at the POUNDS switch is also provided. When a load cell is compressed, the output will shift more positive or possibly negative with time. When the weight exerted on a cell is removed, some zero return will still be present for awhile. The -(minus) POUNDS switch position allows any amount of possible zero return in the load cell output voltage to be evaluated (no load on cell).
 - (c) When the thumbwheel controls are positioned to a weight indication, an output voltage proportional to the weight is produced that is 180° out of phase with the load cell output voltage. The output voltage from the POUNDS switch goes to operational amplifier A3 and the output of A3 goes to operational amplifier A4 to be compared with the load cell output voltage from A2.

1-11. PRINCIPLES OF OPERATION. (Cont)

1-11

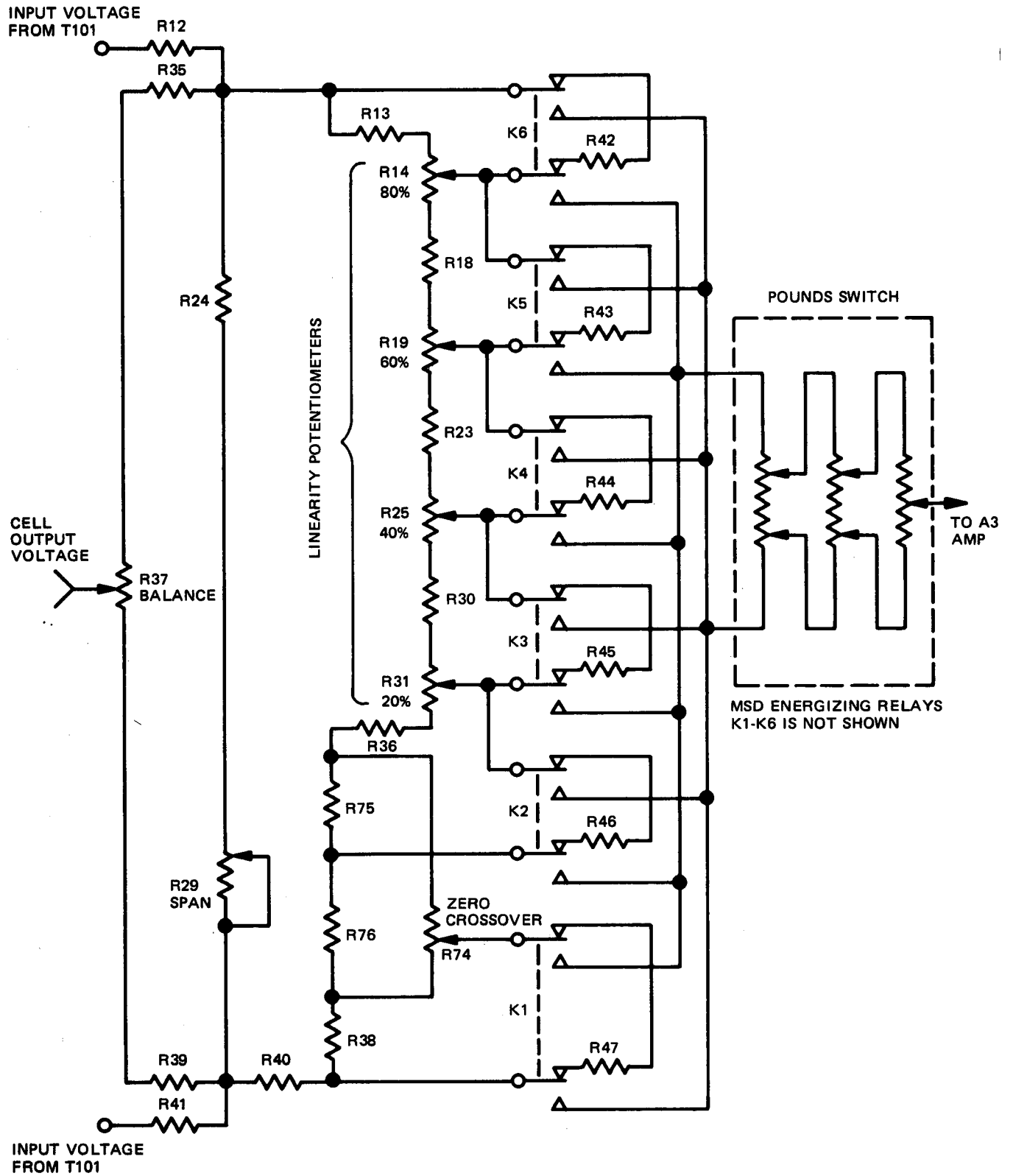
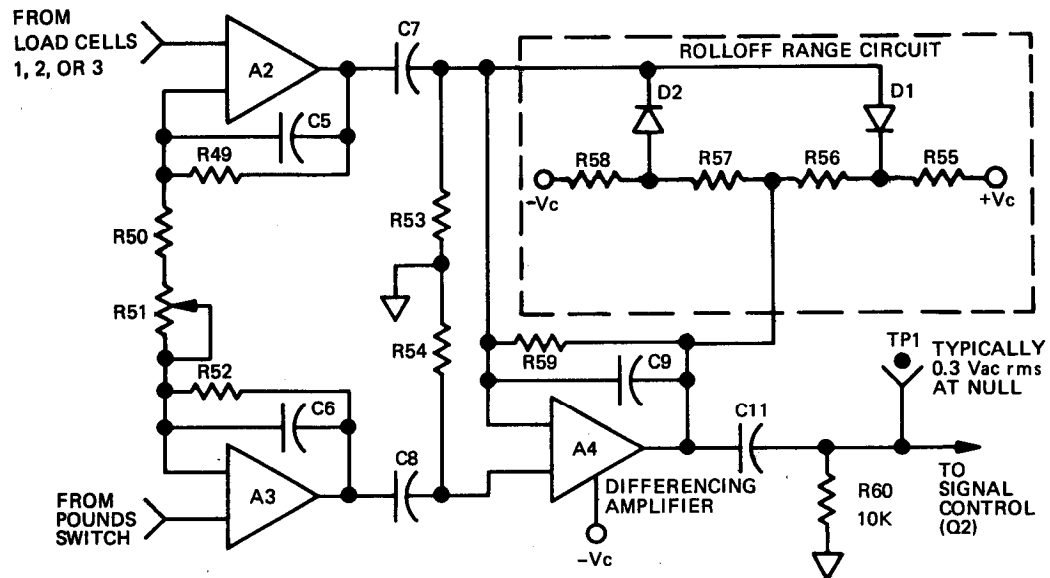

Figure 1-1. Pounds Selector Circuitry

- (5) The use of linearity potentiometers with the POUNDS switch is required because load cell voltage output from 0 to 50,000 pounds is not linear. As load cell steel columns are compressed, resistance to compression increases (output voltage decreases proportionally). Therefore, the POUNDS switch must produce a similar nonlinear output voltage curve in order to compare the load cell output curve at the measuring bridge.
 - (6) The zero crossover potentiometer R74 adjusts the resistances associated with the POUNDS switch S104 MINUS and 0 positions so that null meter M101 reading remains constant (null) at either setting.
 - (7) The main span potentiometer R29 (along with R24) is used to adjust the full scale millivolts output of the measuring bridge so that it compares with the full-scale load cell output voltage of the selected load cell.
- c. Input Amplifiers and Differencing Amplifier.
- (1) Operational amplifier A2 receives the low-level load cell output voltage, while operational amplifier A3 receives the low-level POUNDS switch output voltage 180° out of phase (as shown). Each signal is amplified approximately X100. The gain of both A2 and A3 are simultaneously adjusted by potentiometer R51. Potentiometer R51 is part of the feedback circuitry (C5, R49, C6, R52, and R50) that controls A2 and A3 gain. The feedback circuitry introduces in opposition part of the output of each amplifier back into the negative input of each. Any high frequency noise or harmonics entering A2 and A3 inputs reduces the gain, because a larger portion of the amplifier outputs passes through capacitors C5 and C6 to increase negative feedback.
 - (2) The output of A2 and A3 is ac coupled (C7 and C8) to operational amplifier A4, which functions as a differencing amplifier. The function of differencing amplifier A4 is to compare the amplified load cell sine wave output voltage to the amplified POUNDS switch sine wave output voltage, which is still 180° out of phase. Any voltage common to both the negative and positive inputs is the common-mode signal and is suppressed by A4. Any difference between the voltages at the negative and positive inputs of A4 is amplified and appears at the output of A4.

1-11. PRINCIPLES OF OPERATION. (Cont)

1-11



- (3) **Operational** amplifier A4 has negative feedback circuitry (R59, C9, R53, and R54) that functions in a manner similar to the feedback circuitry of operational amplifiers A2 and A3. The gain, however, is approximately 50. The output of A4 is also controlled by a rolloff range circuit consisting of diodes D1 and D2, and resistors R55, R56, R57, and R58. Resistors R55, R56, R57, and R58 are arranged as a voltage divider powered by plus and minus 10 Volts. The divider reverse biases diodes D1 and D2 so that they will conduct at the desired positive or negative amplitude of the signal out of A4. When the diodes conduct, additional negative feedback is produced to lower A4 signal gain. The rolloff range provided and the time constant of capacitor C13 and resistor R61 protect the pointer of null meter M101 from swinging violently away from NULL as the POUNDS switch thumb-wheels are operated. The combined effect of the feedback circuitry and the rolloff circuitry is that A4 gain increases as the pointer of the null meter approaches NULL and decreases as the pointer is swung away from NULL. The output of A4 goes to field-effect transistor Q2.

d. Signal Control.

- (1) Field-effect transistor Q2 controls the output of operational amplifier A4 to null meter M101 so that only a very small portion of the first 180° of each excitation sine wave cycle passes through from Q2 source to Q2 drain. The biasing circuitry of transistor Q2 alternately removes and restores cut-off bias to Q2 gate to provide control of A4 output.

1-11. PRINCIPLES OF OPERATION. (Cent)

1-11

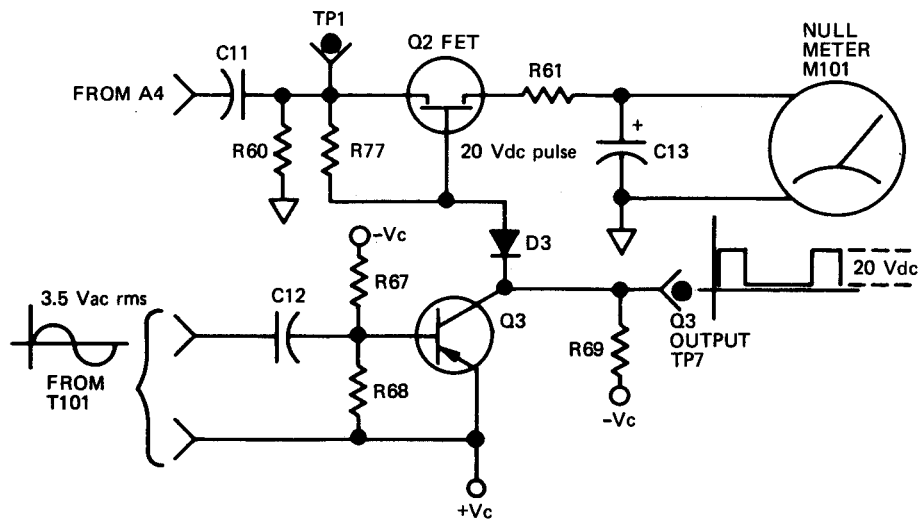

- (2) Field-effect transistor Q2 biasing circuitry consists of a resistor network R60, R67, R68, R77, and R69; transistor Q3, diode D3, and a secondary winding at transformer T101. The resistor network establishes approximately signal common (0V) at Q2 source and -10 Volts at Q2 gate. With Q2 gate biased at -10 Volts, no signal from operational amplifier A4 can pass from Q2 source to Q2 drain.

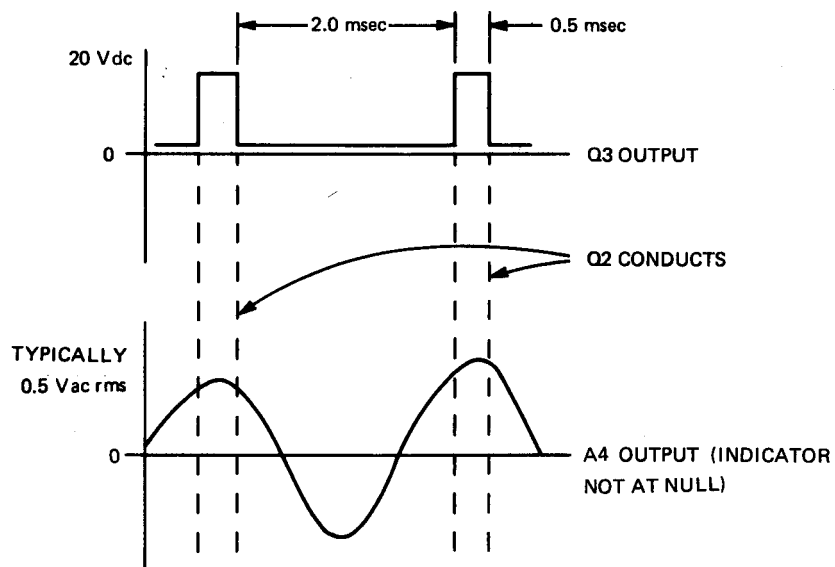

- (3) When the induced sine wave at the secondary winding T101 swings positive, capacitor C12 is charged until a positive potential develops that biases transistor Q3 on. A +10 Volts potential at the emitter of Q3 appears at the collector of Q3 and appears at the cathode of diode D3. Diode D3 stops conducting, effectively opening the resistor network. The -10 Volts bias at Q2 gate changes to 0 Volts, allowing operational amplifier A4 output to pass from Q2 source to Q2 drain. Since only positive peaks from T101 secondary can switch Q3 on, field-effect transistor Q2 gate bias cuts off every other 180° swing of operational amplifier A4 output.
- (4) The output of Q2 (as shown) then goes to a filter consisting of resistor R61 and capacitor C13 to become a varying dc level output for null meter M101.

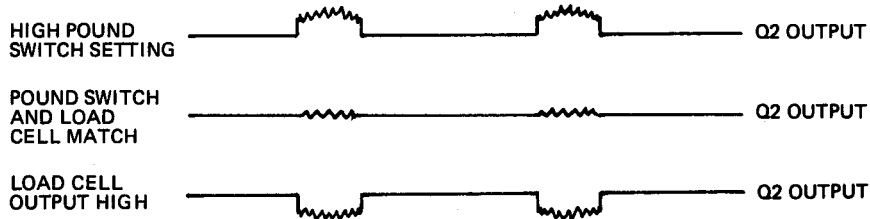

- (5) The null meter M101 is normally held in balance by the output of A4, which goes through R61, C31 filter network. Depending on the difference between the output of the load cell and the output of the POUNDS switch, M101 is driven left or right of center by operational amplifier A4 output. When the POUNDS switch output voltage matches the load cell output voltage, A4 output is typically 0.3 Vat, and M101 will show a null reading.

e. Power Sources.

- (1) Power inputs to the Aircraft Weighing Kit consists of 22 to 28 Vdc or 100-130 Vac. The choice of external power is made by operating the POWER switch S102. The LOAD INDICATOR/BATTERY CHECK switch S103 and resistors R105, R106, and R108, are designed to utilize null meter M101 as a voltmeter so that the level of the incoming operating voltage and polarity can be checked. When dc power is selected by operating POWER switch S102, the positive side goes through fuse F102 to a 1-megohm resistor R105. Resistor R105 reduces the voltage, which then goes through S103 to operate the meter. The degree of meter swing and direction shows the level and polarity of the incoming dc power. The green area of the meter indicates correct polarity and voltage. If the polarity of the dc power is mistakenly reversed, the meter pointer will swing into the yellow area. If the POWER switch S102 is also operated, diode D101 prevents the current from flowing to the rest of the indicator circuitry.

1-11. PRINCIPLES OF OPERATION. (Cent)

1-11

(2) If 115 Vac is selected to power the Aircraft Weighing Kit, a circuit consisting of transformer T2 and diodes D5 and D6 are used to convert 115 Vac to direct current.

(a) Full-wave rectification is accomplished by arranging the components T2, D5, and D6 in a center-tapped design that inverts the negative half of each cycle so that it flows in the same direction as the positive half cycle of the sine wave. The resulting output is a series of positive pulses (two for each sine wave cycle) that is fed to filter capacitor C16. Capacitor C16 produces an approximately steady dc level from the positive pulses.

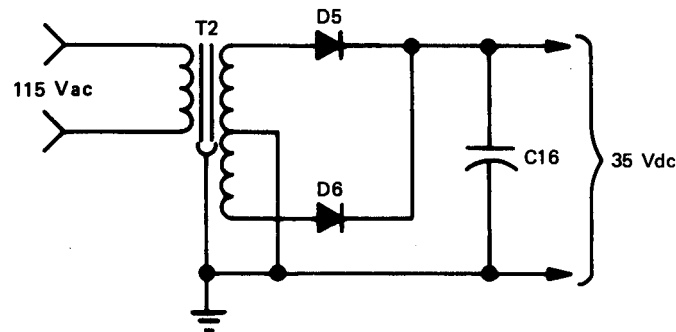

(b) The output of the full-wave rectifier circuit goes through resistors R106 and R108 (1.340 megohms total). These resistors perform the same function as resistor R105, reducing the dc level to drive null meter M101. Resistor R106 is required because the output of the full-wave rectifier is higher (approximately 35 Vdc) than the external dc input (22 to 28 Vdc).

(c) When the choice of external power has been selected by POWER switch S102, power goes to the indicator circuitry. When S103 is momentarily held at the BATTERY CHECK position, null meter M101 shows if the voltage is within range and of the correct polarity. When switch S103 is turned from BATTERY CHECK to LOAD INDICATOR, the null meter ceases to function as a voltage meter.

(3) The voltage regulator consists of transistor Q1, resistor R73, and zener diode D4, arranged as an emitter follower circuit. The collector of Q1 receives between 22 and 35 Vdc, depending on which external power source has been selected by POWER switch S102. Diode D4, which is a 20 V, $\pm 5\%$ zener, sets the base of Q1 at 20 Volts. Resistor R73 functions as a current limiter to protect D4. Due to silicon transistor characteristics, the emitter of Q1 will produce a voltage that is 0.7 Volts less than Q1 base voltage. Thus, as the load current requirement fluctuates or if external dc source varies, Q1 maintains a 19.3-Volt emitter output for the indicator circuitry.

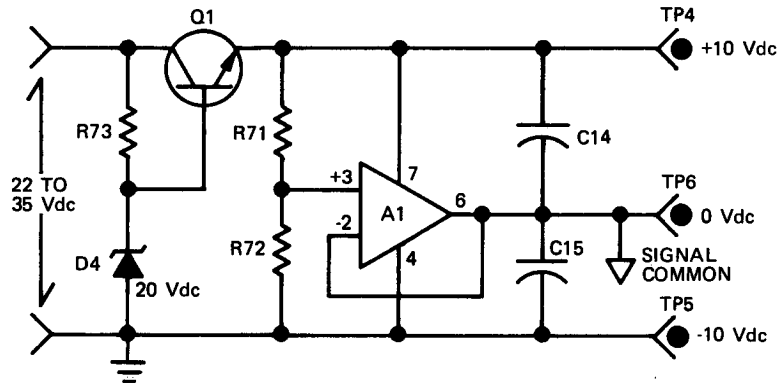

- (4) Operational amplifier A1 establishes a signal common point for the indicator 'circuitry. A voltage divider, consisting of resistors R71 and R72 across the voltage output of transistor Q1, sets a midpoint for the high impedance input of A1. The gain (1) of A1 is maintained by the output at pin 6 being fed to the negative input, pin 2. Power to A1 is through pins 7 and 4. The plus and minus 10 Vdc seen at TP4 and TP5, with reference to TP6 (A1 pin 6 output), is filtered by capacitors C14 and C15 before being used to power A2, A3, and A4. When measuring voltages in relation to the indicator case, the voltages at TP4, TP5, and TP6 are 20, 0, and 10 Vdc, respectively.
- (5) Another power source, consisting of transistors Q6, Q4, and Q5; transformer T101, choke L1, capacitors C10 and C10A, resistors R62, R63, R64, R65, and R66, and associated components, provides sine wave voltages that power the load cells, zero set controls, the measuring bridge, as well as the bias circuitry of field-effect transistor Q2.
 - (a) The sine wave voltages are developed by a push-pull oscillator consisting of transistors Q4 and Q5. Transistors Q4 and Q5 are arranged so that oscillation occurs because the output of each transistor collector passes through a 10K resistor (R65 or R66) to the base of the opposite transistor. Both transistors are operating in a linear region, and any increase in base potential increases collector output. Collector output of each transistor feeds into the opposite ends of transformer T101 primary winding, to the center tap, and then back to the dc source. The frequency of the oscillator is approximately 400 cps nominal and is established by choke L1, capacitor C10, and C10A. Capacitor C10A is used to fine tune the oscillator frequency to minimize indicator circuit ripple and to keep the frequency between the 6th and 7th harmonic of the ac power source frequency.

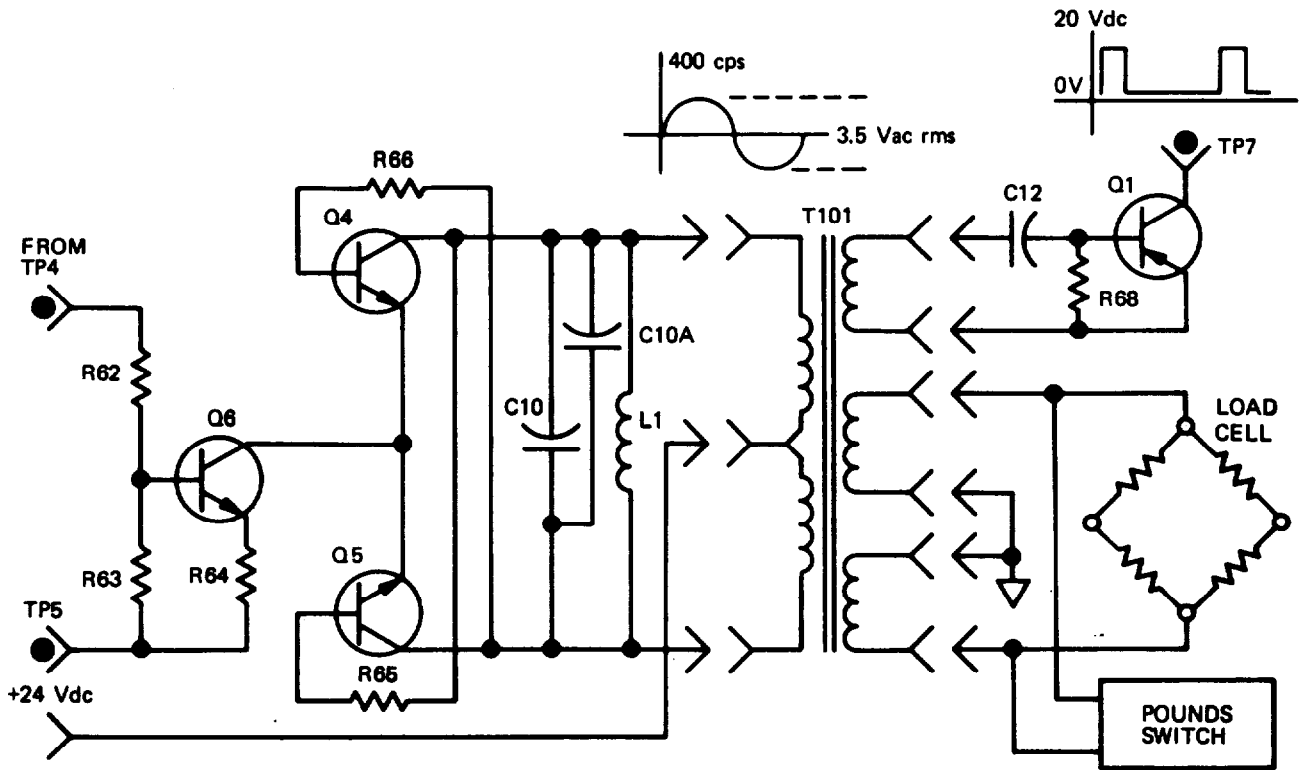

(b) Current regulation for the 400 cycle oscillator is provided by transistor Q6 and resistors R64, R62, and R63. By keeping the current to the 400 cycle oscillator constant, transistors Q4 and Q5 operate in a linear manner to produce a sine wave output. The current is regulated by having the emitter currents of Q4 and Q5 go through Q6 and R64. Two voltage drops occur, one from Q6 collector to emitter, the other across R64.

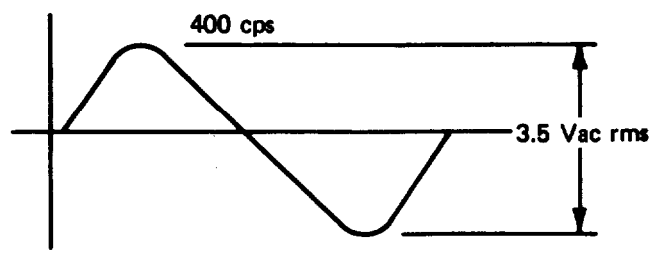

- (c) When current flow increases (sine wave amplitude increases), the voltage at Q6 emitter shifts (increases), approaching the voltage of the base. The reduced voltage difference at Q6 emitter and base decreases current flow from Q6 collector to emitter. Transistor Q6 conducts less, reducing current flow from the oscillator. When current flow decreases (peak of sine wave), current flow across Q6 collector to emitter and across R64 decreases. The voltage at Q6 emitter shifts (lowers), increasing the voltage difference between Q6 emitter and base. Transistor Q6 conducts more, allowing more current to flow from the oscillator. The two extremes of Q6 operation have been described in relation to sine wave development. However, it should be understood that Q6 current regulation happens instantaneously.

CHAPTER 2 OPERATING INSTRUCTIONS

SECTION I- DESCRIPTION AND USE OF OPERATORS CONTROLS AND INDICATORS

2-1. GENERAL.

2-1

This chapter contains instructions for operating the Aircraft Weighing Kit. Operating personnel should be familiar with jacking and leveling procedures necessary for weighing an aircraft.

2-2. PRE-OPERATION PROCEDURES.

2-2

a. Place the kit in a horizontal position, conveniently located so that each 50-foot load-cell cable can be extended to its selected support point of the aircraft to be weighed. Ensure that proper electrical power (100 to 130 Vat, 60 Hz, single phase; or 22 to 28 Vdc) is available to supply the Weighing Kit. Unreel the cell cables and connect each cable to its proper load cell, observing proper color coding (red-to-red, yellow-to-yellow, and blue-to-blue).

NOTE

Cells and cables are factory-calibrated and are not interchangeable for weighing purposes. However, they may be interchanged for test purposes as explained in the troubleshooting section.

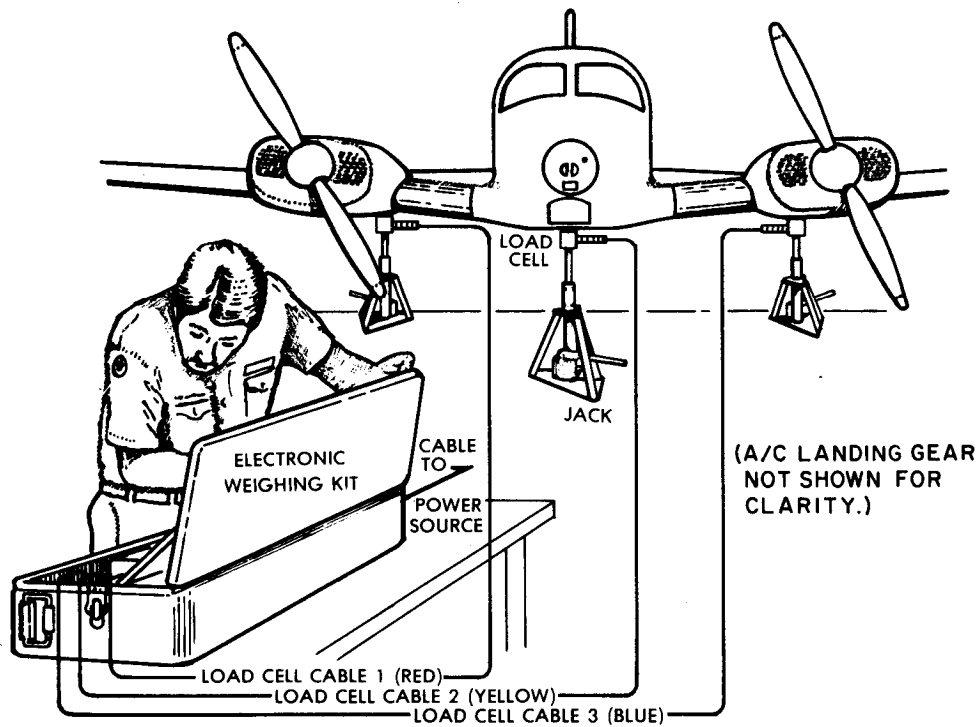

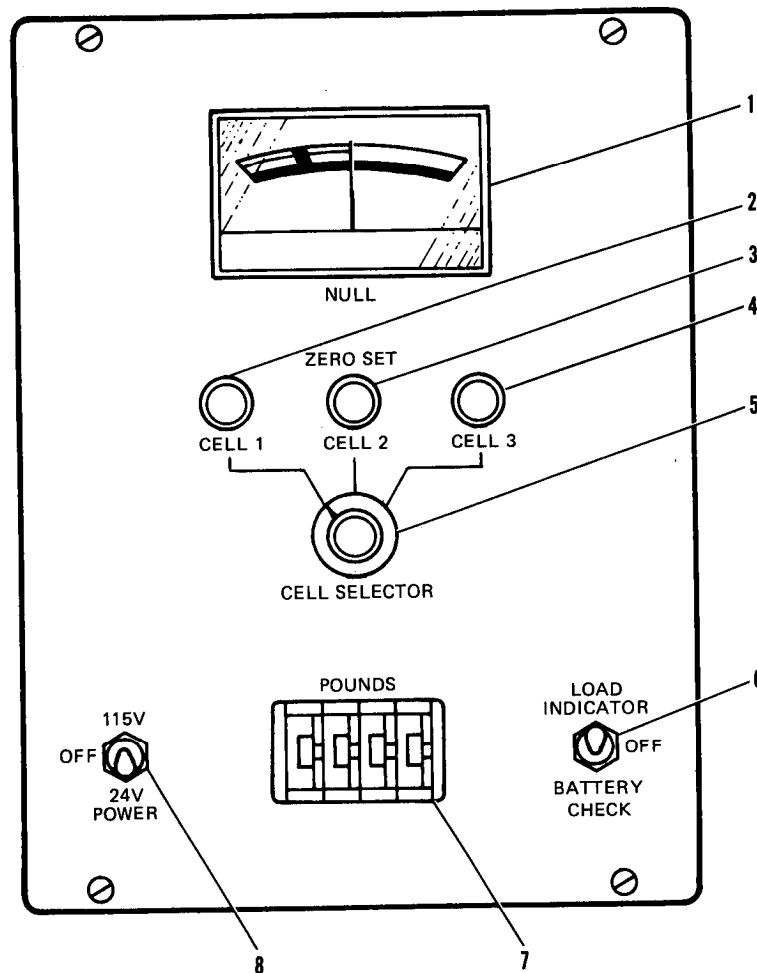

INDICATOR CONTROL FUNCTIONS

1. NULL meter. Used as a galvanometers to determine polarity, sensitivity, and balanced (NULL) voltage conditions.
2. CELL 1 ZERO SET control. Adjusted to balance meter when cell 1 has no load and is connected to the indicator.
3. CELL 2 ZERO SET control. Same except cell 2.
4. CELL 3 ZERO SET control. Same except cell 3.

2-2. PRE-OPERATION PROCEDURES. (Cont)

2-2

5. CELL SELECTOR switch. (Three-position) CELL 1: Connects input from load cell 1 to indicator circuitry.
- CELL 2: Connects input from load cell **2** to indicator circuitry.
- CELL 3: Connects input from load cell **3** to indicator circuitry.
6. LOAD INDICATOR/BATTERY CHECK switch. (Three-position)
- OFF : Disconnects indicator meter (NULL meter) from circuit.
- BATTERY CHECK: Momentarily connects dc input through circuitry to NULL meter in order to check polarity and voltage level which should be between 22 and 28 Vdc.
- LOAD INDICATOR: Connects NULL meter into circuit for normal operation.
7. POUNDS switch: Direct-reading, four-station thumbwheel switch assembly, variable from 0 to 50,000 pounds as follows:
- a. MSD (Most significant digit) left: 0 to 40,000 pounds in 10,000-pound increments. Also indicates minus.
 - b. MSD-1 : 0 to 9000 pounds in 1000-pound increments.
 - c. MSD-2: 0 to 900 pounds in 100-pound increments.
 - d. MSD-3 : 00 to 100 pounds, continuously variable, major divisions marked at five-pound increments.
8. POWER switch: (Three-position)
- a. OFF : Disconnects indicator from power cables.
 - b. 115 v: Connects indicator to 115 Vac power cable.
 - c. 24 V: Connects indicator to 24 Vdc power cable.

2-2. PRE-OPERATION PROCEDURES. (Cont)

2-2

b. Set the LOAD INDICATOR/BATTERY CHECK switch (6) to the OFF (center) position. Set the POWER switch (8) to the OFF (center) position.

(1) If an ac power source is used, connect the 25-foot at-power cable between the 115 VAC receptacle on the left side of the indicator and the power source. Set the POWER switch (8) to the 115 V position to apply power to the indicator. Variations in voltage are automatically compensated for and no adjustment is necessary. Proceed to paragraph 2-2c.

(2) If a dc power source is used, connect the 15-foot dc power cable to the 24 Vdc receptacle on the left side of the indicator and the power source. An auxiliary cable is provided for connection to a battery if required.

(3) Set the LOAD INDICATOR/BATTERY CHECK switch (6) to the momentary BATTERY CHECK position to determine if the dc source polarity is correct and the voltage is within tolerance. If the pointer of the NULL meter (1), swings to the yellow portion of the meter, reverse the power source connections.

(4) After the leads are connected properly, set the LOAD INDICATOR/BATTERY CHECK switch (6) to the momentary BATTERY CHECK position again. The NULL meter (1), must indicate within the green area of the scale (22 to 28 Vdc) for proper operation.

(5) Apply power to the indicator by switching the POWER switch (8) to 24 V.

NOTE

Repeat (4) above frequently to assure that correct voltage is maintained. Unless voltage is maintained within limits throughout the weighing operation, inaccurate readings can result.

c. Keep the power on and allow the equipment to warm up for a minimum of 20 minutes.

NOTE

To minimize temperature variables in the event of ambient temperature near the allowable extremes, attach load cells to jacks as described in paragraph 2-4, and place a partial load on each cell. A stabilizing period of 20 minutes running concurrently with warm-up period is recommended.

2-3. PREPARATION FOR WEIGHING AIRCRAFT.

2-3

Prepare the aircraft for weighing by complying with the specifications listed in TM 55-1500-342-23, Weight and Balance Manual. Refer to the TM of the specific aircraft type for location of proper support points and leveling lugs.

CAUTION

The aircraft should be on a level surface with the main wheels on the surface before installing jacks and load cells. When leveling, be sure there is no side load on the weighing cells. Excessive side loads may cause incorrect readings, cell breakage, and possible damage to the aircraft.

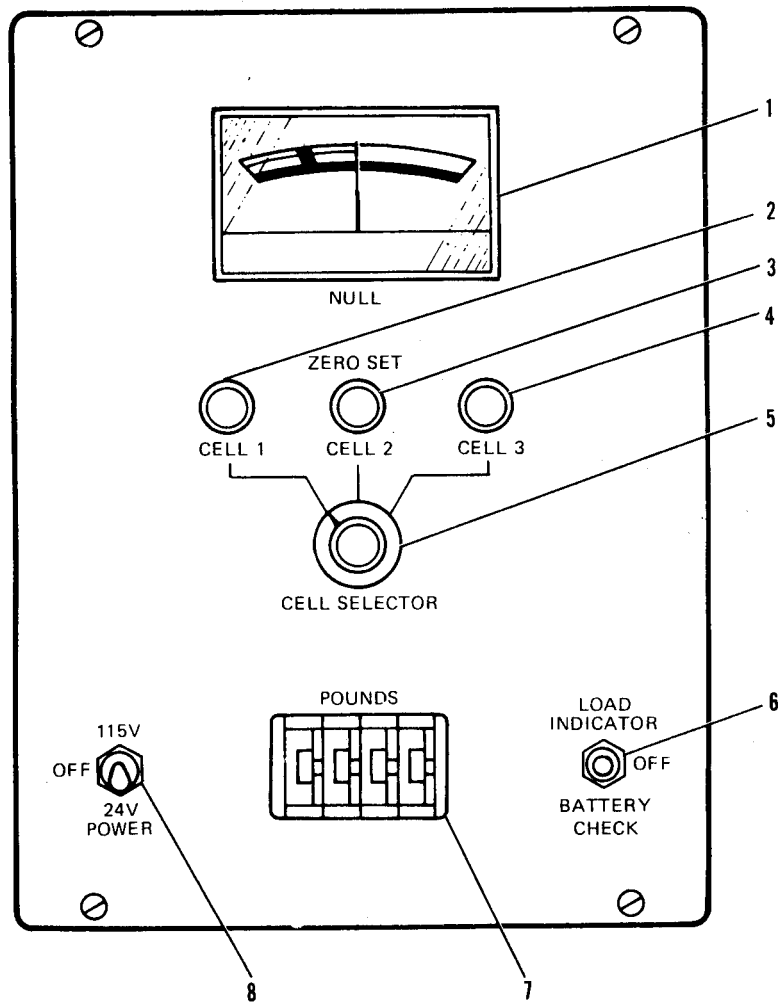

2-4. OPERATIONAL PROCEDURES.

2-4

a. Set the cells on their respective jacks, selecting jack adapters and spherical adapters in accordance with the illustration to the right. In attaching a load cell to jack adapter, be sure that the adapter is completely threaded into the cell. If a ring-type adapter is used, ensure that it is centered flush on the ram, applying a partial load to it before tightening the set screws. When screws have been tightened, release partial load.

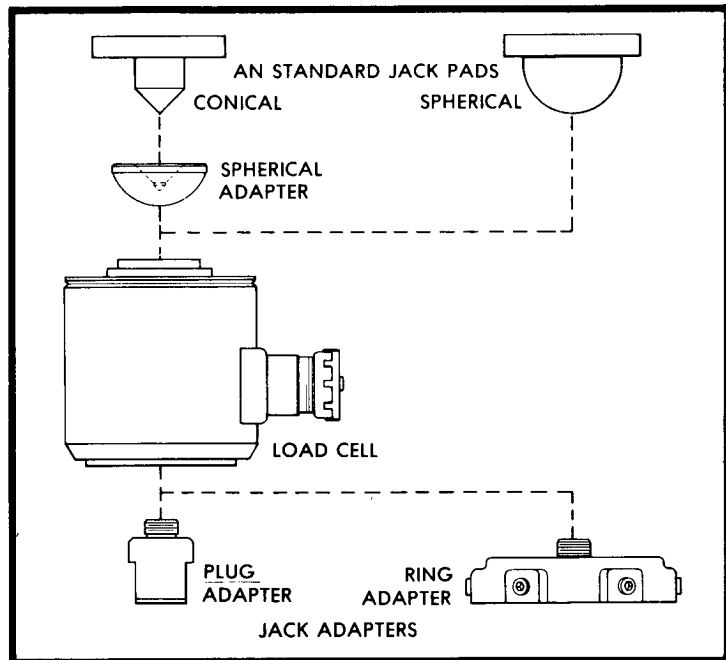

ADAPTER APPLICATIONS

CAUTION

Use proper adapters to prevent jacks from slipping or buckling. Damage to the aircraft or inaccurate weight readings may result if improper adapters are used. Never apply load to rim of cell.

- b. Set the jacks and cells at their respective support points.
- c. Turn LOAD INDICATOR/BATTERY CHECK switch (6) to LOAD INDICATOR. There must be no load on the cells at this time.
- d. Set the POUNDS switch (7) thumbwheels to 0-0-0-00.
- e. Set the CELL SELECTOR switch (5) to CELL 1. Adjust the pointer of the NULL meter (1) to null by adjusting the ZERO SET control (2) of CELL 1. The meter pointer moves in the same direction as the rotation of the knob. Repeat this procedure for the remaining cells (3) and (4). Once the cell circuits are zeroed, the ZERO SET control must not be touched until weight is off the cells.

CAUTION

The aircraft must be kept level while jacking; have a man operating each jack simultaneously, and another observing the level on the leveling lugs.

- f. Jack the aircraft until it is supported entirely by the cells.

2-4. OPERATIONAL PROCEDURES. (Cm)

2-4

g. To read the weight on the cell(s), turn the CELL SELECTOR switch (5) to the CELL 1 position. Adjust the POUNDS switch (7) thumbwheels to read all zeros. Start with the POUNDS switch thumbwheel on the left, MSD (most significant digit). Advance this thumbwheel until the pointer of the NULL meter (1) swings across zero from right to left, then move back one digit. Advance the POUNDS switch second thumbwheel from the left until the meter again swings across zero from right to left, then move back one digit. Repeat this procedure for the POUNDS switch third thumbwheel from the left. Finally, balance the pointer at zero on the meter scale by adjusting the far right POUNDS switch thumbwheel adjustment. Read the weight directly on the POUNDS switch thumbwheel dials.

h. Repeat this procedure for each of the remaining positions of the CELL SELECTOR switch (5). The total uncorrected weight is the sum of all loads on each cell. In order to determine the corrected weights on each load cell, multiply the indicated values by a latitude correction factor. This correction factor is needed because of mass-to-weight variations at different latitudes. The latitude correction factors are listed in table 2-1.

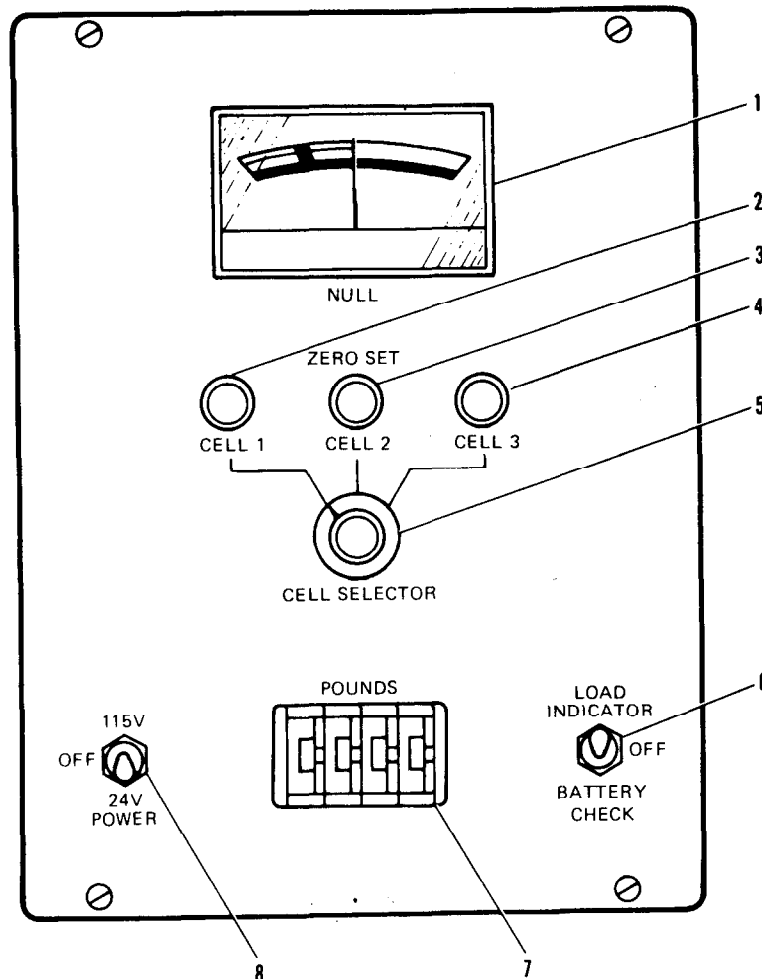

2-4. OPERATIONAL PROCEDURES. (Cont)

Table 2-1. Latitude Correction Factors

Latitude	Correction Factor	Latitude	Correction Factor
0	1.0027	50	0.9996
5	1.0026	55	0.9991
10	1.0025	60	0.9987
15	1.0023	65	0.9984
20	1.0021	70	0.9980
25	1.0017	75	0.9978
30	1.0014	80	0.9976
35	1.0010	85	0.9974
40	1.0005	90	0.9974
45	1.0000		

2-5. DETERMINING CENTER OF GRAVITY.

a. Record the corrected weight at the support points in the applicable spaces on the Airplane Weighing Record DD Form 365B, as shown in TM 55-1500-342-23, Weight and Balance Manual.

b. Make sure that the aircraft is in a level flight attitude. Use the plumb bobs, furnished in the accessory kit, to establish points on the ground that are directly beneath each cell and the aircraft's reference point as shown in the Weight and Balance Manual. Mark these points with the chalk provided.

c. Measure the horizontal distance from each support to the reference datum on a line parallel to the aircraft's longitudinal axis. Use the 600-inch tape that is marked in inches and tenths of inches. Enter these measurements on the weighing form (DD Form 365B) in the space provided.

d. At this point, determine scale correction. (Whether the zero set control of the cell has been altered). Use the following procedure:

(1) Remove all load from the cells.

(2) Adjust the POUNDS switch until the NULL meter pointer is on zero. If a small plus reading is obtained, divide the value by two and subtract it from the total weight reading for that cell. If there is a small minus reading, add one-half the amount indicated to the reading obtained for that cell. If there is an appreciable difference (greater than 10 pounds), repeat the entire weighing procedure.

e. With the completion of weighing operations, turn off all switches, disconnect cables and replace all components in their proper places in the case.

SECTION II - OPERATOR PREVENTIVE MAINTENANCE CHECKS AND SERVICES (PMCS)

2-6. BEFORE YOU OPERATE.

2-6

Always keep in mind CAUTIONS and WARNINGS. Handle the Aircraft Weighing Kit like you would any other delicate electronic equipment. See table 2-2 for normal preventive maintenance checks and services.

Table 2-2. Operator/Crew Preventive Maintenance Checks and Services

NOTE : Within designated interval, these checks are to be performed in the order listed.

Item No.	Interval			Item to be Inspected	Procedures Check for and have repaired or adjusted as necessary	Equipment is Not Ready/ Available if:
	B	D	A			
	●			Case Assy	Check for damage to fiberglass case.	Contents wet or damaged.
	●		●	Component parts	Check components for damage or dirt. Clean as necessary.	Indicator panel is damaged or broken, return for repair and calibration.
	●		●	Cable Assys	Check for loose or broken cables or connectors. Replace cables.	If replacement of load cell cable is necessary, unit must be recalibrated. Return for repair and calibration.
	●	●	●	AC-DC Power Cable	Check for loose or broken cables on connectors. Replace as necessary. Check BATTERY CHECK function using external dc power source.	Cables require repair. Indication not within green band.

SECTION III - OPERATION UNDER USUAL CONDITIONS

2-7. NORMAL OPERATION CONDITIONS.

2-7

The aircraft weighing procedure should be carried out in a hanger or suitably-enclosed area. Care should be taken to prevent wind loads on the aircraft or the indications will be in error. Allow the proper warm up time (20 minutes) for the equipment to stabilize. Do not use when ambient temperatures occur that are not within the limits (32°F to 120°F).

SECTION IV - OPERATION UNDER UNUSUAL CONDITIONS

2-8. OPERATION UNDER UNUSUAL CONDITIONS.

2-8

This equipment will not be used under unusual conditions. Parameters of paragraph 2-7 must be met.

CHAPTER 3

AVIATION UNIT MAINTENANCE (AVUM) - MAINTENANCE INSTRUCTIONS

SECTION I - REPAIR PARTS, SPECIAL TOOLS, TMDE, AND SUPPORT EQUIPMENT

3-1. GENERAL

3-1

This chapter contains maintenance procedures that are the responsibility of the aviation unit maintenance technician as authorized by the Maintenance Allocation Chart (MAC) and Source Maintenance and Recoverability (SMR) coded items in the Repair Parts and Special Tools List (RPSTL). The maintenance procedures in this chapter are prepared in the form of summary and detailed procedures.

3-2 MAINTENANCE OPERATIONS.

3-2

These instructions provide the proper technique and detailed procedures required to perform the maintenance operations. Each maintenance operation provides step-by-step instructions in the order in which the work is most logically accomplished. Any unusual or critical steps are covered in detail.

3-3. COMMON TOOLS AND EQUIPMENT.

3-3

Tools required for maintenance of the weighing kit are contained in Tool Kit: Electrical Repairer: Army Aircraft, NSN 5180-00-323-4915, SC 5180-99-CL-A06.

3-4. SPECIAL TOOLS, TMDE, AND SUPPORT EQUIPMENT.

3-4

There are no special tools required for test or inspection procedures at the AVUM level. The only support equipment required are standard aircraft jacks, appropriate to the size and weight of the aircraft being weighed. Refer to TM of aircraft being weighed for specific information.

3-5 REPAIR PARTS.

3-5

Repair parts are listed in the repair parts and special tools list (RPSTL), APPENDIX C of this manual.

SECTION II - SERVICE UPON RECEIPT

3-6. GENERAL.

3-6

Visually check the exterior of the weighing kit for any apparent damage. Check contents of weighing kit to assure that all components listed in the Repair Parts and Special Tools List (RPSTL, figures C-1, and C-2) of this manual are enclosed and undamaged.

SECTION III - PREVENTIVE MAINTENANCE CHECKS AND SERVICES (PMCS)

3-7. GENERAL.

3-7

Preventive maintenance for the Aircraft Weighing Kit is covered by the following paragraphs and information listed in table 2-2, as well as the Notes and Cautions in Chapter 2. These Notes and Cautions, if followed, assure that the equipment will be used in the proper manner.

3-8. CLEANING.

3-8

WARNING

Isopropyl alcohol is flammable; and toxic. Use with adequate ventilation, gloves and eye protection. Do not use around heat, open flames, or sparks.

CAUTION

Use a soft cloth dampened with isopropyl alcohol for cleaning. Isopropyl alcohol is the only acceptable cleaning solvent that may be used on the POUNDS thumbwheel switch S104. Fumes from other solvents will damage switch.

1. Keep equipment free of dirt and grease. Place protective dust covers over the receptacles on load cells when not in use.

2. Clean load cells prior to use to assure good mating surfaces for the adapters.

3-9. LUBRICATION.

3-9

There are no requirements for lubrication of the Aircraft Weighing Kit.

3-10. EXTREME ENVIRONMENTAL MAINTENANCE.

3-10

There are no requirements for extreme environmental maintenance for the Aircraft Weighing Kit.

3-11. PERFORMANCE CHECKS.

3-11

1. A complete performance check of the Weighing Kit is not possible at the aviation unit maintenance (AVUM) level because results cannot be verified without an accurate 0-50,000-pound dead weight machine, or equivalent. However, a function check of the null meter can be performed. Refer to TASK 1, paragraph 3-12.

2. Visually inspect the Aircraft Weighing Kit, accessory kit, electronic weighing indicator, switches, fuses, fuseholder, null meter, transformer oscillator, zero set control, resistors and capacitors, connectors, terminal board. circuit card assembly, load cells and cables, and power-cables. Refer to the tasks-in Chapters 3 (AVUM) and 4 (AVIM) for applicable procedures.

3-12 NULL METER FUNCTION CHECK.

3-12

TASK 1

Initial Set-up:

APPLICABLE CONFIGURATION:

Aircraft Weighing Kit, Type A/S 37M-1

PERSONNEL REQUIRED:

68F Aircraft Electrician

TOOLS/TEST AND SUPPORT EQUIPMENT:

Adjustable ac or dc power source.

EQUIPMENT CONDITION:

Kit operational.

Performance:

SET UP INDICATOR AND LOAD CELLS ACCORDING TO DIAGRAM.

- a. Connect each of the load cell cables to its respective load cell according to color code.
- b. Connect ac power cable to indicator and then to a 100- to 130-Vac power source, or connect dc power cable to indicator and then to a 22- to 28-Vdc power source.

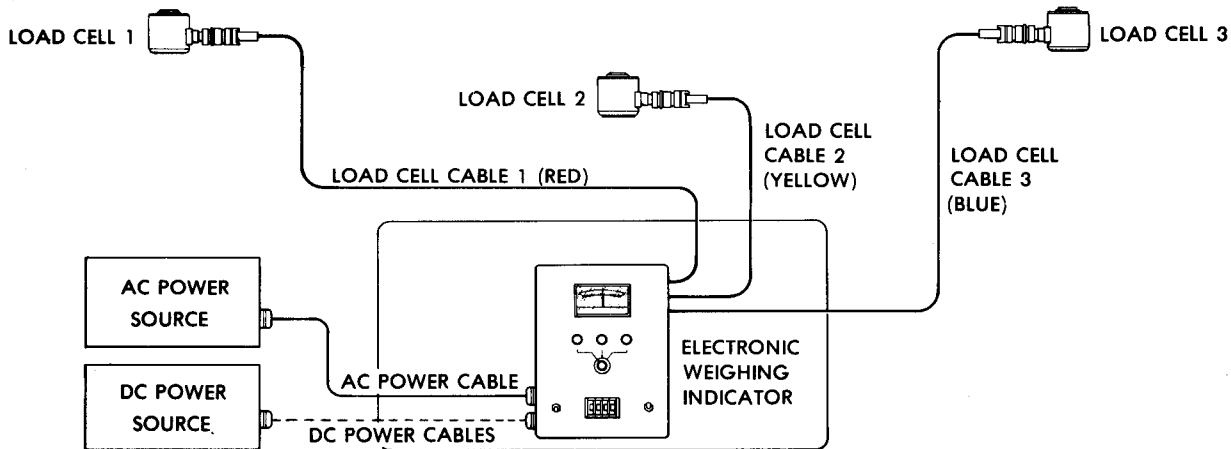

GO TO NEXT PAGE

NOTE

Set the LOAD INDICATOR/BATTERY CHECK switch to the momentary BATTERY CHECK position and note that the null meter deflects to the green portion of the meter; thus indicating that power cables, power switch, and fuse are good and that the null meter is operational. When using 115 Vac power source, set POWER switch (1) to 115 V in order to read null meter.

- c. Set the POWER switch (1) to 115 V or 24 V position as applicable.

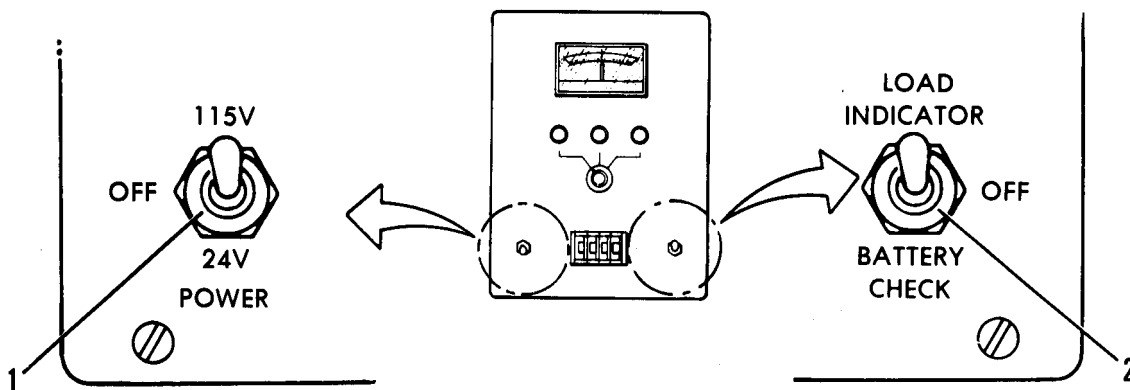

- d. Set the LOAD INDICATOR/BATTERY CHECK switch (2) to the LOAD INDICATOR position.
- e. Set the CELL SELECTOR switch (3) to the CELL 1 position.

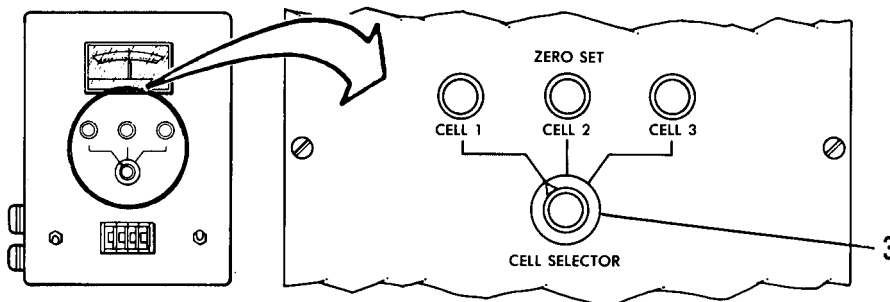

GO TO NEXT PAGE

3-12. NULL METER FUNCTION CHECK. (Cent)

3-12

- f. With no load on the cell, set the POUNDS switch (4) to 0-0-0-00, and adjust the CELL 1 ZERO SET control (5) in order to obtain a null indication on the meter (6). Momentarily rotate the CELL 1 ZERO SET control beyond a null reading to check condition of the control.

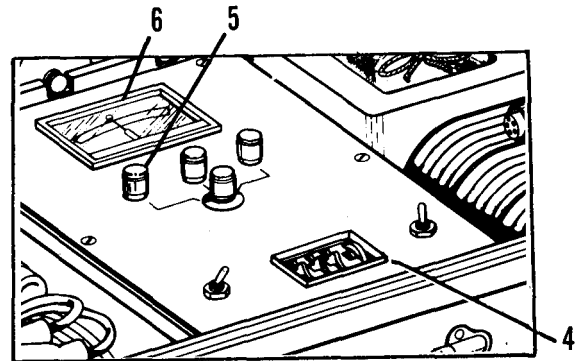

- g. Set the POUNDS switch (4) to 210 pounds.
- h. Observe that the pointer of the null meter (6) deflects to the green area. If meter does not deflect return kit for repair and calibration.
- i. Set the POUNDS switch (4) to 0-0-0-00.
- j. With a spherical adapter placed on load cell, exert pressure with the palm of hand and check that the pointer on the null meter (6) deflects to the beginning of the yellow band. If the pointer does not deflect, return the aircraft weighing kit for repair and calibration.
- k. Repeat steps f through j for CELLS 2 and 3.
- l. Shut off all switches and disconnect the power cable from power source, then from the indicator housing, disconnect load cell cables, and return all components to their storage compartments in the kit.

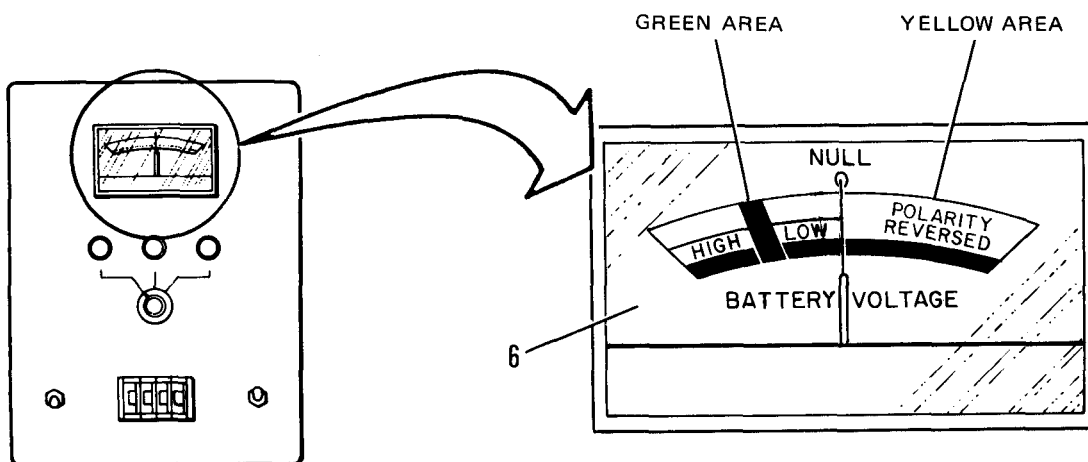

END OF TASK

SECTION IV - TROUBLESHOOTING

3-13. GENERAL.

3-13

Troubleshooting at the aviation unit maintenance (AVUM) level is limited to checking- the system for indications of normal operation (TASK 1), inspection, and replacing ac or dc cables and ac or dc fuses. Inspection and replacement procedures are described in TASKS 2 through 6 in the following pages.

NOTE

Electrical components (except fuses and power cables) are factory calibrated and will not be replaced or interchanged in the field because erroneous weight readings may result.

If the indicator is inoperative, switch to alternate power source (ac to dc, or dc to ac) before removing any of the cables or the indicator cover. If the indicator is operational in the alternate power mode, fuse failure in the initial power mode is probable. However, first check the initial power source for availability of power. If the source is functioning, perform TASK 6 and inspect the appropriate power cable for signs of damaged, shorted, or open wiring, or a faulty connector.

3-14. AIRCRAFT WEIGHING KIT INSPECTION.

3-14

TASK 2

Initial Set-up:

APPLICABLE CONFIGURATION:

Aircraft Weighing Kit, Type A/S 37M-1

MATERIALS:

Fiberglass kit as needed.

PARTS :

As needed.

PERSONNEL REQUIRED:68F Aircraft Electrician
68G Aviation Structural RepairerREFERENCES:TM 55-1500-204-25/1
Para 3-8. CLEANING
APPENDIX C, Figure C-1EQUIPMENT CONDITION:

Power disconnected. Kit on work bench.

Performance:

OPEN CASE ASSEMBLY COVER.

- a. Visually inspect Aircraft Weighing Kit for external damage.
- b. Repair fiberglass case if damaged; refer to TM 55-1500-204-25/1.
- c. Check that all components are accounted for and undamaged.
- d. Replace all missing parts; refer to APPENDIX C, Figure C-1.
- e. Clean all components and surfaces; refer to paragraph 3-8.

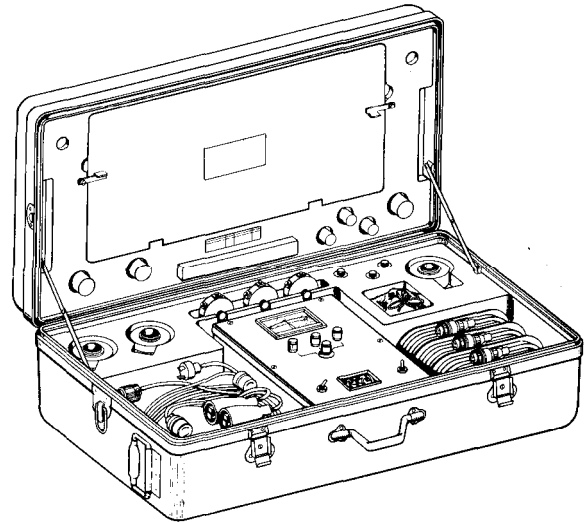

END OF TASK

TASK 3

Initial Set-up:

APPLICABLE CONFIGURATION:

Aircraft Weighing Kit, Type A/S 37M-1

PARTS :

As needed.

PERSONNEL REQUIRED:

68F Aircraft Electrician

REFERENCES:

Para 3-8. CLEANING
APPENDIX C, Figure C-2

EQUIPMENT CONDITION:

Power disconnected.
Accessory kit removed from Aircraft
Weighing Kit.

Performance:

OPEN CASE ASSEMBLY COVER.

- a. Check that all components are accounted for and undamaged.
- b. Replace missing parts; refer to APPENDIX C, Figure C-2.
- c. Clean all components and mating surfaces; refer to paragraph 3-8.

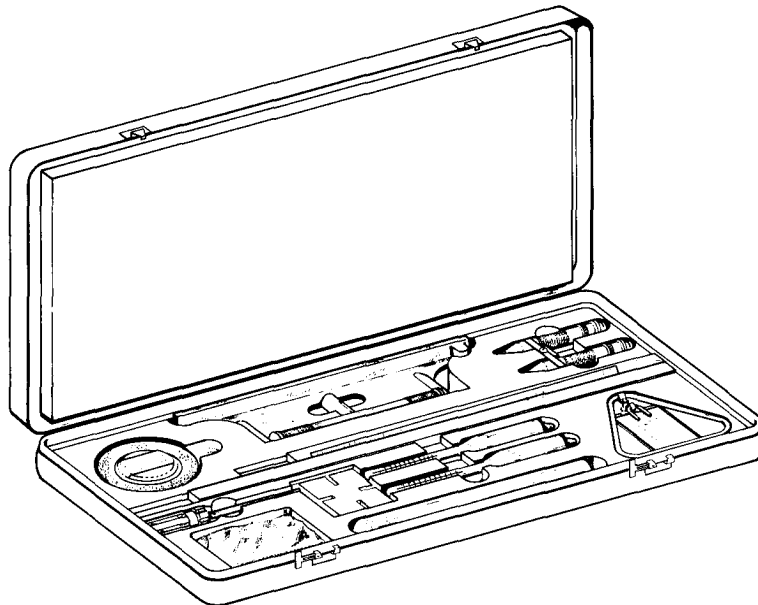

END OF TASK

SECTION V - MAINTENANCE PROCEDURES

3-16. INDICATOR COVER REMOVAL/INSTALL.

3-16

TASK 4

Initial Set-up:

APPLICABLE CONFIGURATION:

Aircraft Weighing Kit, Type A/S 37M-1

TOOLS/TEST AND SUPPORT EQUIPMENT:Tool Kit: Electrical Repairer,
Army Aircraft, NSN 5180-00-323-4915MATERIALS:

Cloth.

PERSONNEL REQUIRED:

68F Aircraft Electrician

EQUIPMENT CONDITION:Power disconnected. Kit on
workbench, cover open.

Performance:

1. REMOVE INDICATOR COVER FROM INDICATOR HOUSING.

CAUTION

When removing cover be careful not to pull any wires loose.

- a. Loosen the six captive screws (1) that fasten the indicator cover (2) to the indicator housing (3).
- b. Place cloth on Aircraft Weighing Kit to left of indicator panel, lift indicator cover (2) from housing (3), turning it over and placing it on the protective material to the left of housing (internal wiring harness restricts movement in other directions).

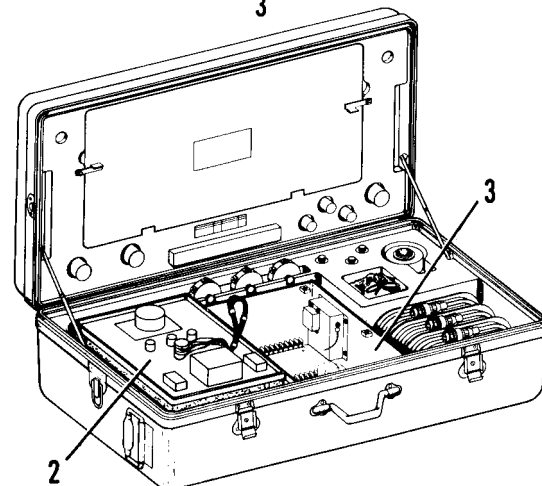
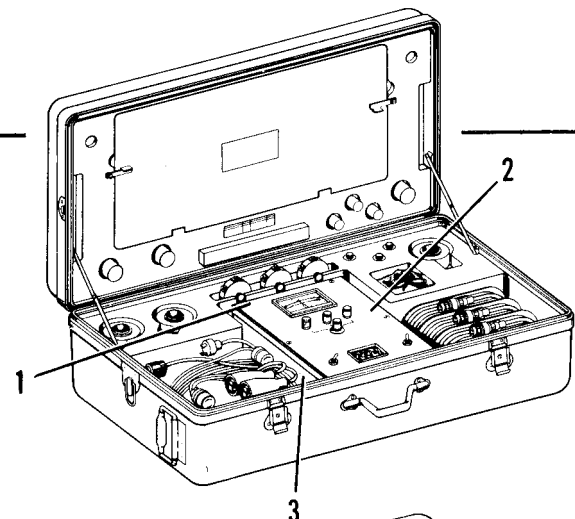

GO TO NEXT PAGE

3-16. INDICATOR COVER REMOVAL/INSTALL. (Cent)

3-16

2. INSTALL INDICATOR COVER ON INDICATOR HOUSING.

CAUTION

When installing cover be careful not to pull any wires loose.

- a. Lift indicator cover (2) from its rest position on cloth packing, turn cover over and place in position on indicator housing (3); make sure wiring harness is inside housing and that wires are not pinched.
- b. Align six captive screws (1) in their mounting holes to the indicator housing (3).
- c. Tighten captive screws (1) to fasten cover (2) to housing (3).

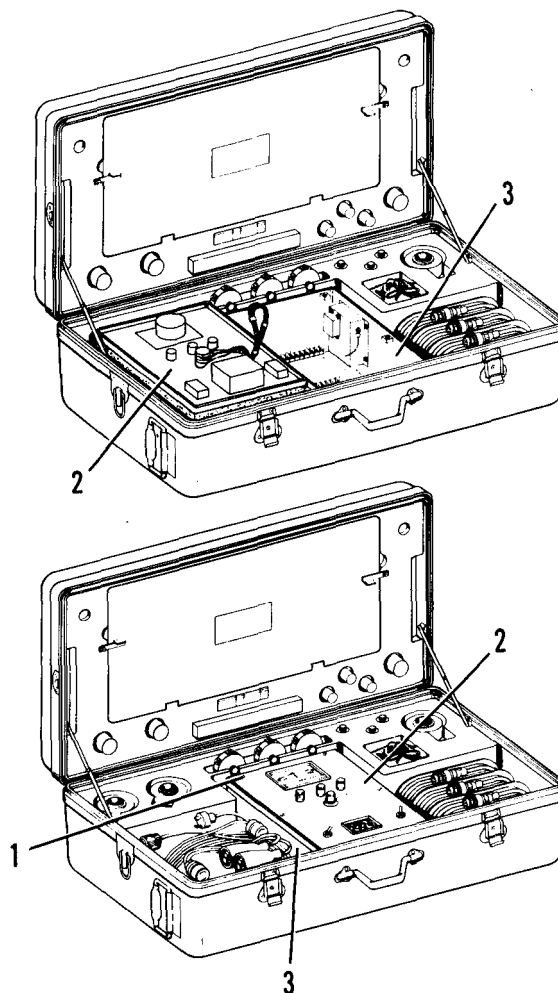

END OF TASK

3-17. FUSE REMOVAL/REPLACEMENT.**3-17****TASK 5**

Initial Set-up:

APPLICABLE CONFIGURATION:

Aircraft Weighing Kit, Type A/S 37M-1

TOOLS/TEST AND SUPPORT EQUIPMENT:Tool Kit: Electrical Repairer,
Army Aircraft, NSN 5180-00-323-4915PARTS :

Fuses: 1/2A, 1/4A, as required.

PERSONNEL REQUIRED:

68F Aircraft Electrician

REFERENCES:3-12. TASK 1 NULL METER FUNCTION
CHECK.
3-16. TASK 4 INDICATOR COVER
REMOVAL/INSTALL .
APPENDIX C, Figure C-3EQUIPMENT CONDITION:Power disconnected. Kit on workbench,
cover open; indicator cover removed
from indicator housing.

Performance:

REMOVE/REPLACE AC AND DC FUSES.

- a. Visually check 1/4A ac fuse F101 (1) and 1/2A dc fuse F102 (2) to see if either needs to be replaced.
- b. Remove fuses (1 and 2), as required.
- c. Replace with new fuses of correct value as stated in APPENDIX C, Figure C-3.

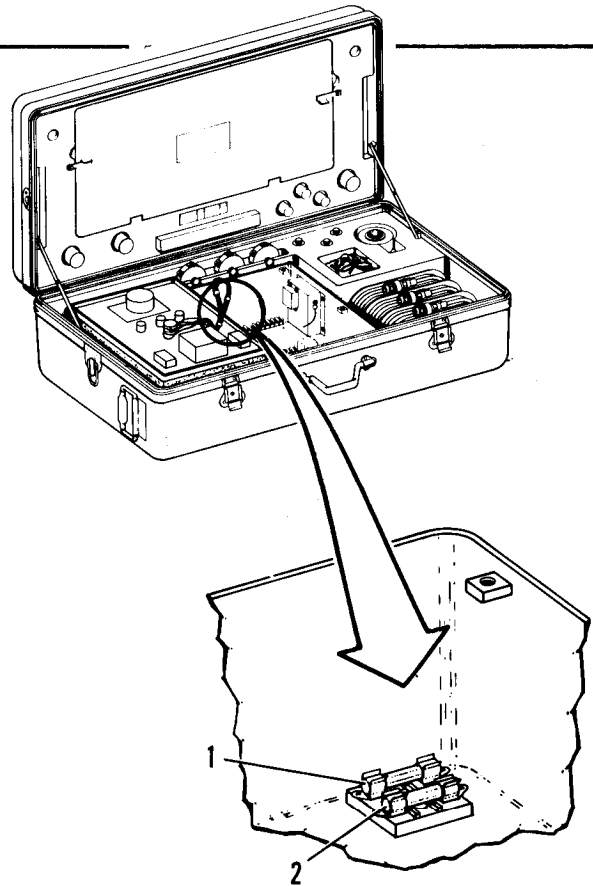

GO TO NEXT PAGE

3-17. FUSE REMOVAL/REPLACEMENT. (Cont)

3-17

- d. Install indicator cover (3); refer to paragraph 3-16.
- e. Apply power to the indicator and check to ensure that weighing kit is operational; refer to paragraph 3-12.

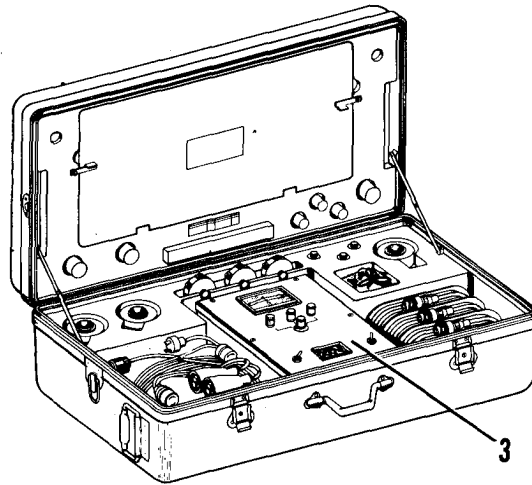

END OF TASK

3-18 AC AND DC POWER CABLE INSPECTION/REPLACEMENT.

3-18

TASK 6

Initial Set-up:

APPLICABLE CONFIGURATION :

Aircraft Weighing Kit, Type A/S 37M-1

TOOLS/TEST AND SUPPORT EQUIPMENT :

Multimeter: AN/PSM-45 or equivalent
 Tool Kit: Electrical Repairer,
 Army Aircraft, NSN 5180-00-323-4915

PARTS :

As required.

PERSONNEL REQUIRED :

68F Aircraft Electrician

REFERENCES:

3-12. TASK 1 NULL METER FUNCTION
 CHECK.
 APPENDIX C, Figure C-5

EQUIPMENT CONDITION:

Power disconnected. Power Cables
 removed from Kit.

Performance:

INSPECT AC AND DC POWER CABLES AND BATTERY EXTENSION CABLE.

- a. Inspect the ac and dc power cables and the battery extension cable for breaks, loose or broken wires, and loose or broken connectors.
- b. Replace cables as required. (Refer to APPENDIX C, Figure C-5.)
- c. Connect cables, one conductor at a time, to multimeter and check for continuity and shorts. Flex cables while testing.
- d. Perform NULL METER FUNCTION CHECK according to paragraph 3-12.

END OF TASK

3-19. PREPARATION FOR STORAGE.

3-19

The Aircraft Weighing Kit may be stored using normal procedures. General instructions are provided in TM 1-1500-204-23 (Series). The case is moisture- and dust-proof when the lid is closed and secured.

3-20. PREPARATION FOR SHIPMENT.

3-20

The Aircraft Weighing Kit may be reshipped using normal electronic equipment shipping procedures.

CHAPTER 4

AVIATION INTERMEDIATE MAINTENANCE (AVIM) - MAINTENANCE INSTRUCTIONS

SECTION I - REPAIR PARTS, SPECIAL TOOLS TMDE, AND SUPPORT EQUIPMENT

4-1. GENERAL.

4-1

This chapter contains maintenance procedures that are the responsibility of the Aviation Intermediate Maintenance (AVIM) technician as authorized by the Maintenance Allocation Chart (MAC) and Source, Maintenance and Recoverability (SMR) coded items in the Repair Parts and Special Tools List (RPSTL). The maintenance procedures in this chapter are prepared in the form of summary and detailed procedures.

4-2. MAINTENANCE OPERATIONS.

4-2

These instructions provide the proper technique and detailed procedures required to perform the maintenance operations. Each maintenance operation provides step-by-step instructions in the order in which the work is most logically accomplished. Any unusual or critical steps are covered in detail.

4-3. COMMON TOOLS AND EQUIPMENT.

4-3

Tools required for AVIM maintenance of the weighing kit are contained in Tool Kit : Tool Kit 35H Calibration Set, NSN 6695-01-081-0705.

4-4 SPECIAL TOOLS, TMDE, AND SUPPORT EQUIPMENT.

4-4

Special tools required for inspection and testing of the Aircraft Weighing Kit are listed in the RPSTL and in TM 55-1500-342-23, Weight and Balance Manual. Refer to TM on specific aircraft being weighed for information on proper jacks and support points.

4-5. REPAIR PARTS.

4-5

Repair parts are listed in the Repair Parts-and Special Tools List (RPSTL), APPENDIX C, of this manual.

SECTION II - SERVICE UPON RECEIPT

4-6. GENERAL.

4-6

a. Visually check the exterior of the weighing kit for apparent damage. Check contents of weighing kit to assure that all components listed in APPENDIX C (RPSTL) of this manual are enclosed and undamaged.

b. If the equipment has been damaged, report the damage on SF 368, Report of Discrepancies. Check the equipment against the packing slip to see if the shipment is complete. Report any discrepancies in accordance with the instructions of DA PAM 738-751.

SECTION III - PREVENTIVE MAINTENANCE CHECKS AND SERVICES (PMCS)

4-7. GENERAL.

4-7

Preventive maintenance for the Aircraft Weighing Kit is covered by the following paragraphs as well as the Notes and Cautions in Chapter 2, and information listed in Table 2-2. These Notes and Cautions, if followed, assure that the equipment will be used in the proper manner.

4-8. CLEANING.

4-8

WARNING

Isopropyl alcohol is flammable and toxic. Use with adequate ventilation, gloves and eye protection. Do not use around heat, open flames, or sparks.

CAUTION

Use a soft cloth dampened with isopropyl alcohol for cleaning. Isopropyl alcohol is the only acceptable cleaning solvent which may be used on the POUNDS thumbwheel switch, S104. Fumes from other solvents may damage switch.

Keep equipment free of dirt and grease. Place protective dust covers over the receptacles when not in use.

4-9. LUBRICATION.

4-9

There are no requirements for lubrication of the Aircraft Weighing Kit.

4-10. EXTREME ENVIRONMENTAL MAINTENANCE.

4-10

There are no requirements for extreme environmental maintenance for the Aircraft Weighing Kit.

4-11. PERFORMANCE CHECK.

4-11

Calibration of the Aircraft Weighing Kit will be performed by Area TMDE Support Team (ATST), because results cannot be verified without an accurate 0-50,000 pound deadweight machine, or equivalent. However, a performance check and a bench calibration procedure can be performed that will verify that indicator is capable of being calibrated, using a deadweight machine. If an aircraft weighing kit fails to perform correctly in a test step, the 35H Calibration and Repair Specialist is referred to the applicable FAULT ISOLATION paragraph.

TASK 7

Initial Set-up:

APPLICABLE CONFIGURATION:

Aircraft Weighing Kit, Type A/S 37M-1

TOOLS/TEST AND SUPPORT EQUIPMENT:

Tool Kit: 35H Calibration Set
NSN 6695-01-081-0705
Load cell simulator, Revere Model R941
or equivalent
Multimeter: AN/PSM-45 or equivalent
Oscilloscope: Triggerable, dual beam,
500 Kc minimum bandwidth
Adjustable ac power supply 100-135 Vat,
60 Hz
Adjustable dc power supply 22-28 Vdc
Adapter cable for load cell to simu-
lator connection: Connector number
GS02-14S-5P-001 attached to
four 8" color-coded wires

PERSONNEL REQUIRED:35H Calibration and Repair
SpecialistREFERENCES:

- 4-14. AIRCRAFT WEIGHING KIT
INSPECTION/FAULT ISOLATION.
- 4-16. 115-VAC RECEPTACLE RESISTANCE
FAULT ISOLATION.
- 4-17. 24-VDC RECEPTACLE RESISTANCE
FAULT ISOLATION.
- 4-18. AC POWER SUPPLY FUNCTION FAULT
ISOLATION.
- 4-19. TEST POINT VOLTAGE CHECK FAULT
ISOLATION.
- 4-20. DC EXTERNAL POWER CHECK FAULT
ISOLATION.
- 4-21. TP-4 STABLE VOLTAGE CHECK
FAULT ISOLATION.
- 4-22. ADJUSTMENT OF ZERO SET CONTROLS
FAULT ISOLATION.
- 4-23. NULL METER FUNCTION CHECK FAULT
ISOLATION.
- 4-24. YELLOW BAND CHECK FAULT ISOLATION.
- 4-39. TASK 8 INDICATOR COVER
REMOVAL/INSTALL .
- 4-58. TASK 27 BENCH ALIGNMENT.

EQUIPMENT CONDITION:

Power disconnected.
Indicator cover removed from housing.

GENERAL SAFETY INSTRUCTIONS:

Use caution when operating around
unguarded 115 Vac energized circuits.

GO TO NEXT PAGE

4-12. AIRCRAFT WEIGHING KIT PERFORMANCE CHECK. (Cont)

4-12

Performance:

SET UP INDICATOR, POWER SOURCES, AND TEST EQUIPMENT ACCORDING TO DIAGRAM.

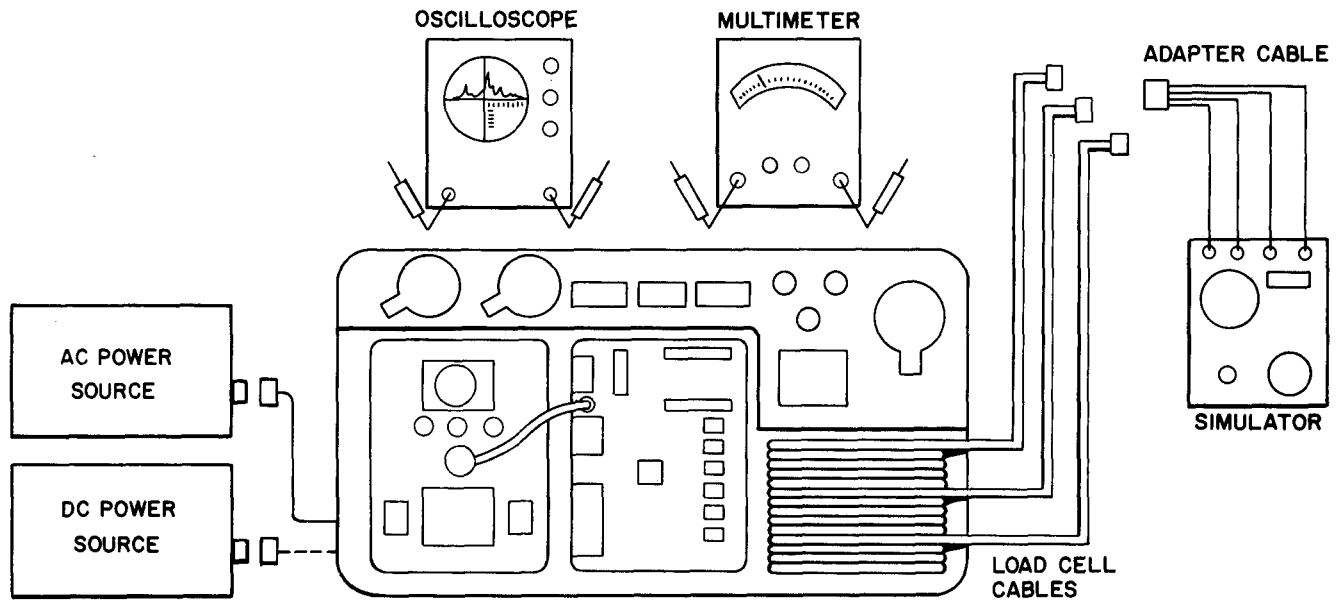

- a. Inspect entire kit for damage and missing parts; refer to paragraph 4-14.
- b. Use the battery extension cable for tests requiring external dc power source.
- c. Do not connect load-cell cable or power cables until cable and electrical checks have been made.
- d. Perform checkout of ac and dc power cables.
 - (1) Visually check power cables for damage and/or loose or broken connectors.
 - (2) Make continuity check of cable wires using a multimeter; flex cables while testing continuity.
- e. Perform electrical checks on electronic weighing indicator using a multimeter.

GO TO NEXT PAGE

4-12. AIRCRAFT WEIGHING KIT PERFORMANCE CHECK. (Cont)

4-12

- (1) Turn POWER switch to 115 V position.
- (2) Measure resistance across terminals of 115 Vac receptacle on the left side of indicator using multimeter; multimeter should indicate approximately 75 to 125 ohms. If another indication is observed, see paragraph 4-16.
- (3) Set POWER switch to 24 V position.
- (4) Measure resistance across terminals of 24 Vdc receptacle on the left side of indicator using multimeter (positive multimeter lead goes to smaller receptacle pin, larger pin is -Vdc or case ground); multimeter should indicate 100 to 200 ohms (diode D101 forward resistance). If another indication is observed, refer to paragraph 4-17.
- (5) Set POWER switch to OFF position.
- (6) Measure the resistance between hot and ground pins and between neutral and ground pins of 115 Vac receptacle. Resistance should be infinite; if not refer to paragraph 4-16.
- (7) Measure the resistance across the pins of the 24 Vdc receptacle placing the positive multimeter probe on the positive pin. The resistance should be 2.34 megohms; if not, refer to paragraph 4-17.
- (8) Remove indicator cover (refer to paragraph 4-39) and inspect indicator (refer to paragraph 4-15).
- (9) Arrange indicator cover so that the null meter may be observed while making following adjustments. Observe and compensate for null meter pointer shift due to indicator cover position.

**WARNING****HIGH VOLTAGE**

Use extreme caution when operating with ac power as primary voltage exists on 115-Vac receptacle (J103), filters (FL3 and FL4), fuse (F101), switch (S102), edge connector (J102), and at various points on the printed circuit card. Death can result from accidental contact.

GO TO NEXT PAGE

CAUTION**HIGH VOLTAGE**

Do not allow indicator cover switches to short out to case. Severe damage to the indicator could result.

- f. Perform the following checks of the ac power source and the dc power source. See following illustration for location of test points and potentiometers.
- (1) Connect the ac power cable to the 115-Vac receptacle on the left side of the indicator and then to ac power source.
 - (2) Set the POWER switch to 115 V position.
 - (3) Set the LOAD INDICATOR/BATTERY CHECK switch to the momentary BATTERY CHECK position to determine if the internal 115 Vac to 35-Vdc power supply is functioning. Null meter should indicate a reading in the green band; if not, refer to paragraph 4-18.
 - (4) Check voltages at TP-4, TP-5, and TP-6 with reference to case ground using multimeter. (See Figure 4-1.) Multimeter should indicate +20, 0, and +10 Vdc respectively; if not, refer to paragraph 4-19.
 - (5) Set POWER switch to OFF position.
 - (6) Disconnect the ac power cable at the ac power source.
 - (7) Connect the dc power cable between the 24 Vdc receptacle on the left side of the indicator and the dc power source.
 - (8) Set POWER switch to 24 V position.
 - (9) Set the LOAD INDICATOR/BATTERY CHECK switch to the momentary BATTERY CHECK position to determine if the external dc power source polarity is correct and the voltage is within the green band. If the pointer of the null meter swings to the yellow position of the meter, reverse the dc power source connections. If voltage is outside green band, refer to paragraph 4-20.
 - (10) Check voltages at TP-4, TP-5, and TP-6 with reference to case ground using multimeter. Multimeter should indicate +20, 0, and +10 Vdc respectively; if not, refer to paragraph 4-19.
 - (11) "Adjust dc power source from 22 to 28 Volts while checking for stable +20 Vdc at TP-4; if not stable, refer to paragraph 4-21.

GO TO NEXT PAGE

4-12 AIRCRAT WEIGHING KIT PERFORMANCE CHECK. (Cont)

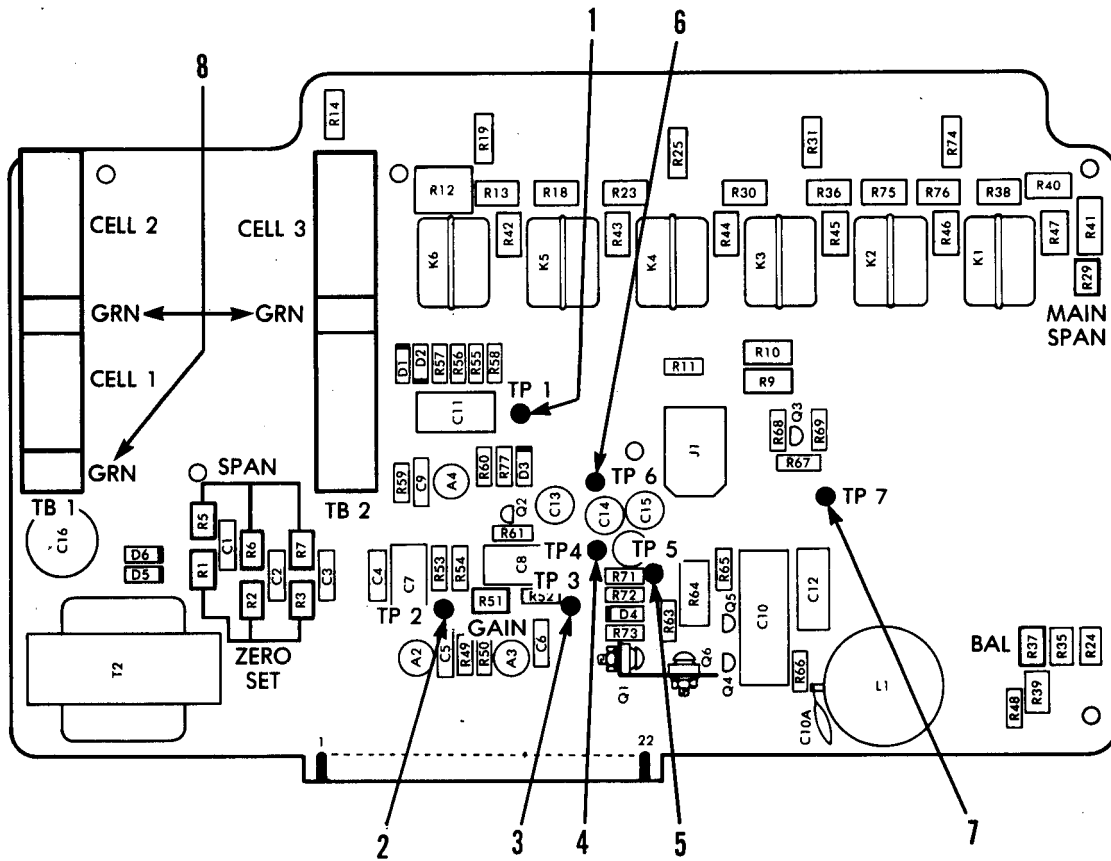

TEST POINTS

TYPICAL WAVEFORMS

1. TP-1. Operational amplifier A4 output (ac). 
2. TP-2. Operational amplifier A2 output (ac). 
3. TP-3. Operational amplifier A3 output (ac). 
4. TP-4. Transistor Q1 20 Vdc output with reference to case ground.
5. TP-5. Case ground 0 Vdc or -10 Vdc with reference to TP-6.
6. TP-6. Operational amplifier A1 output; signal common or 10 Vdc with reference to case ground.
7. TP-7. Transistor Q3 Vdc pulse output for Q2 (signal control). 
8. TP-8. Transformer T101 Vac output. 

Figure 4-1. Test Point Locations

GO TO NEXT PAGE

4-12. AIRCRAFT WEIGHING KIT PERFORMANCE CHECK. (Cont)

4-12

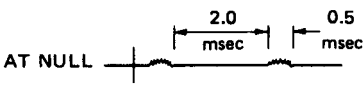
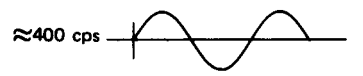
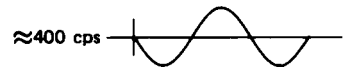
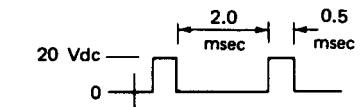
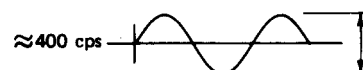
- g. Perform the following checks of the load cells and cables.
- (1) Turn off external dc power source.
 - (2) Unreel the cell cables sufficiently to connect each cable to its proper load cell, observing proper color coding (red to red, yellow to yellow, and blue to blue).
 - (3) Turn on external dc power source; adjust the dc power source for an output of between 22 and 28 Volts.
 - (4) Set the POUNDS switch thumbwheels to 0-0-0-00.
 - (5) Set the CELL SELECTOR switch to CELL 1.
 - (6) Adjust R101 (Cell 1 ZERO SET control) until null meter indicates NULL (see figure 4-1); if reading cannot be obtained, refer to paragraph 4-22.
 - (7) Set the POUNDS switch to 0-0-2-10 to perform null meter function check; observe that the pointer of the null meter deflects to the beginning of the green band or further left; if meter does not deflect, refer to paragraph 4-23.
 - (8) Set the POUNDS switch thumbwheels to 0-0-0-00.
 - (9) With a spherical adapter placed on load CELL 1, exert pressure with the palm of your hand and check that pointer of the null meter deflects to the beginning of the yellow band or further; if meter does not deflect, refer to paragraph 4-24.
 - (10) Repeat steps 6 to 9 for load CELLS 2 and 3.
 - (11) Turn off external dc power source.
 - (12) Disconnect the load cells and return them to the recesses in the Aircraft Weighing Kit.
 - (13) Disconnect the dc power cable at the dc power source.
 - (14) If Aircraft Weighing Kit performs correctly and if it requires calibration, proceed to step h of BENCH ALIGNMENT, paragraph 4-58. Performance of the bench alignment procedure will further test the kit to determine if kit functions properly and if it can be properly calibrated using a deadweight machine.

END OF TASK

SECTION IV - TROUBLESHOOTING

4-13. GENERAL.

4-13

A list of possible failures to the Aircraft Weighing Kit, as well as probable cause and corrective action are shown in the following fault isolation block diagrams. Corrective action, as shown in these diagrams, is outlined in the applicable removal/replacement paragraphs in the text of this manual.

4-14. AIRCRAFT WEIGHING KIT INSPECTION /FAULT ISOLATION.

4-14

Initial Set-up:

APPLICABLE CONFIGURATION:

Aircraft Weighing Kit, Type A/S 37M-1

TOOLS/TEST AND SUPPORT EQUIPMENT:

Air Frame Repairer Tool Kit:
 NSN 5180-00-323-4876
 SC-5180-99-CL-A02

MATERIALS:

Fiberglass kit as needed.

PARTS :

As needed.

PERSONNEL REQUIRED:

35H Calibration and Repair Specialist
 68 G Aviation Structural Repairer

REFERENCES:

APPENDIX C, Figures C-1, C-2, and C-5.

EQUIPMENT CONDITION:

Power disconnected. Kit on work bench.

Performance:

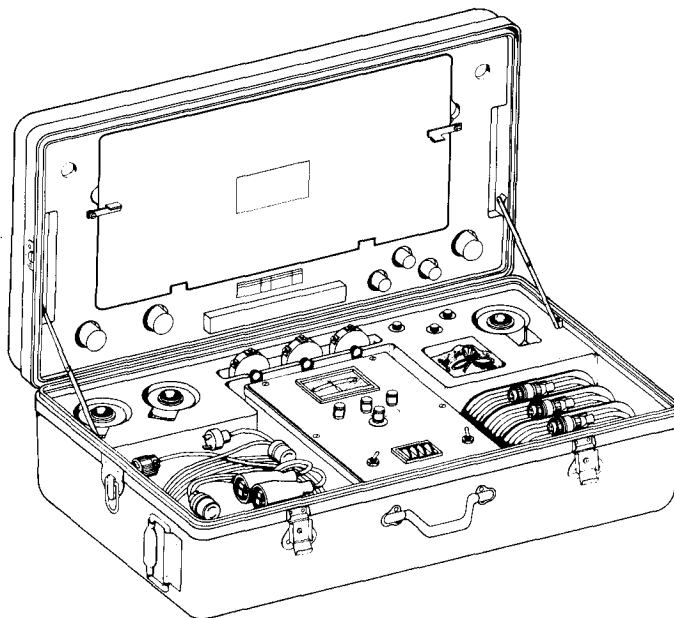

GO TO NEXT PAGE

4-14. AIRCRAFT WEIGHING KIT inspection/FAULT ISOLATION. (Cont)

4-14

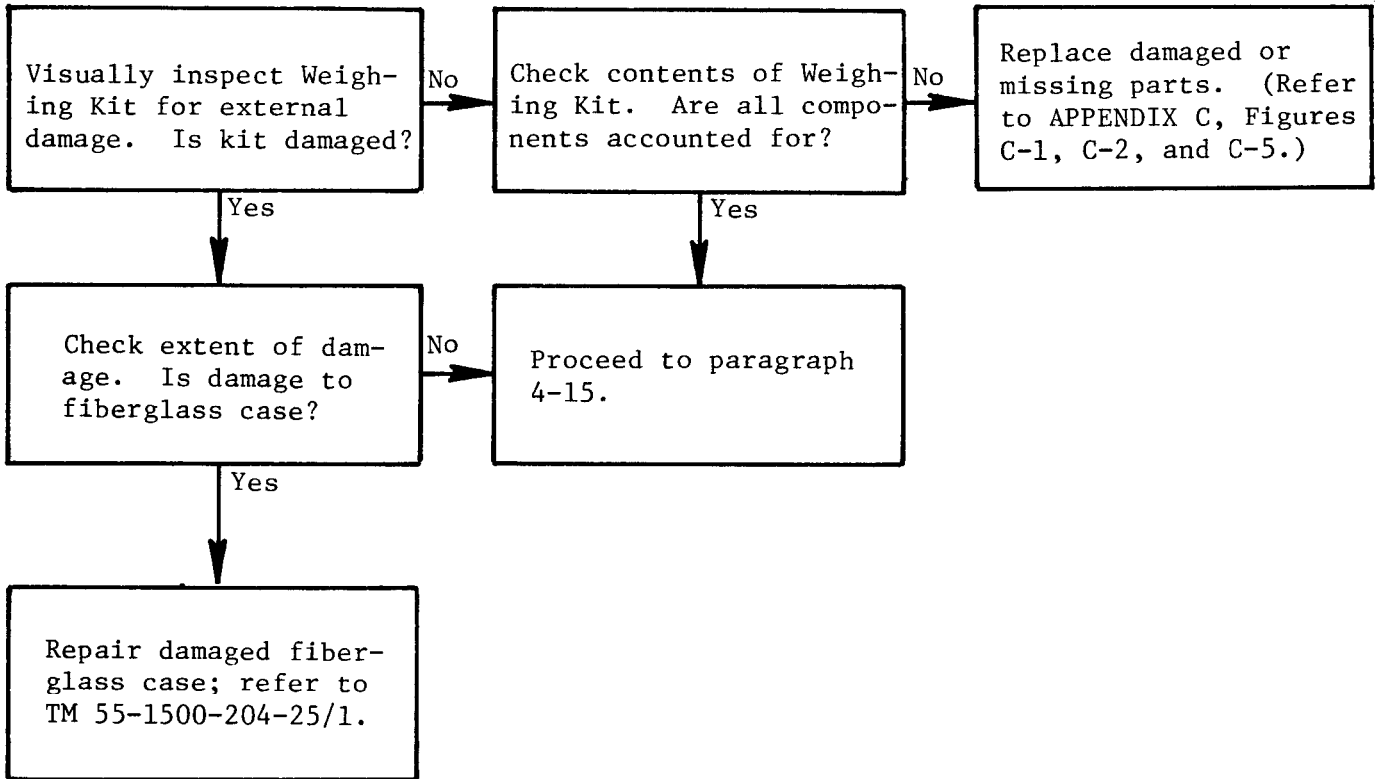

END OF TASK

4-15. INDICATOR INSPECTION/FAULT ISOLATION.

Initial Set-up:

APPLICABLE CONFIGURATION:

Aircraft Weighing Kit, Type A/S 37M-1

PERSONNEL REQUIRED:

35H Calibration and Repair Specialist

TOOLS/TEST AND SUPPORT EQUIPMENT:

Tool Kit: 35H Calibration Set,
NSN 6645-01-081-0705

REFERENCES:

4-39. TASK 8 INDICATOR COVER
REMOVAL/INSTALL.

MATERIALS:

As needed.

EQUIPMENT CONDITON:

Power disconnected.

Kit on bench.

Indicator cover removed from
indicator housing.

PARTS:

As needed.

Performance:

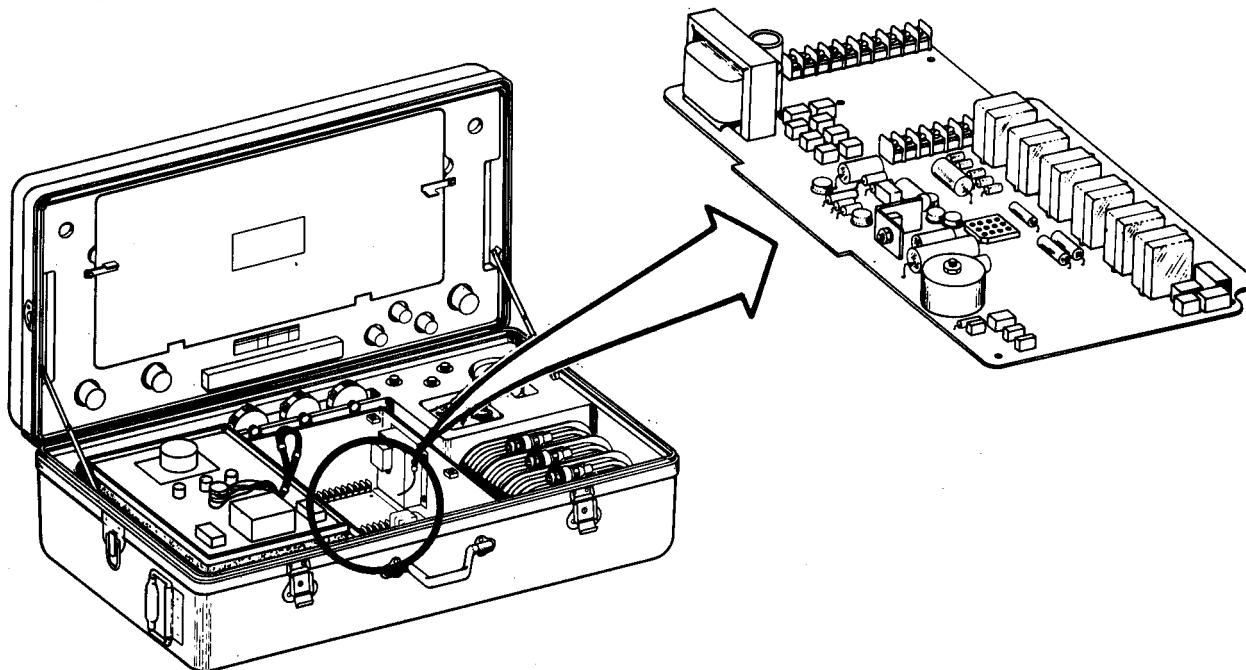

GO TO NEXT PAGE

4-15. INDICATOR INSPECTION/FAULT ISOLATION. (Cont)

4-15

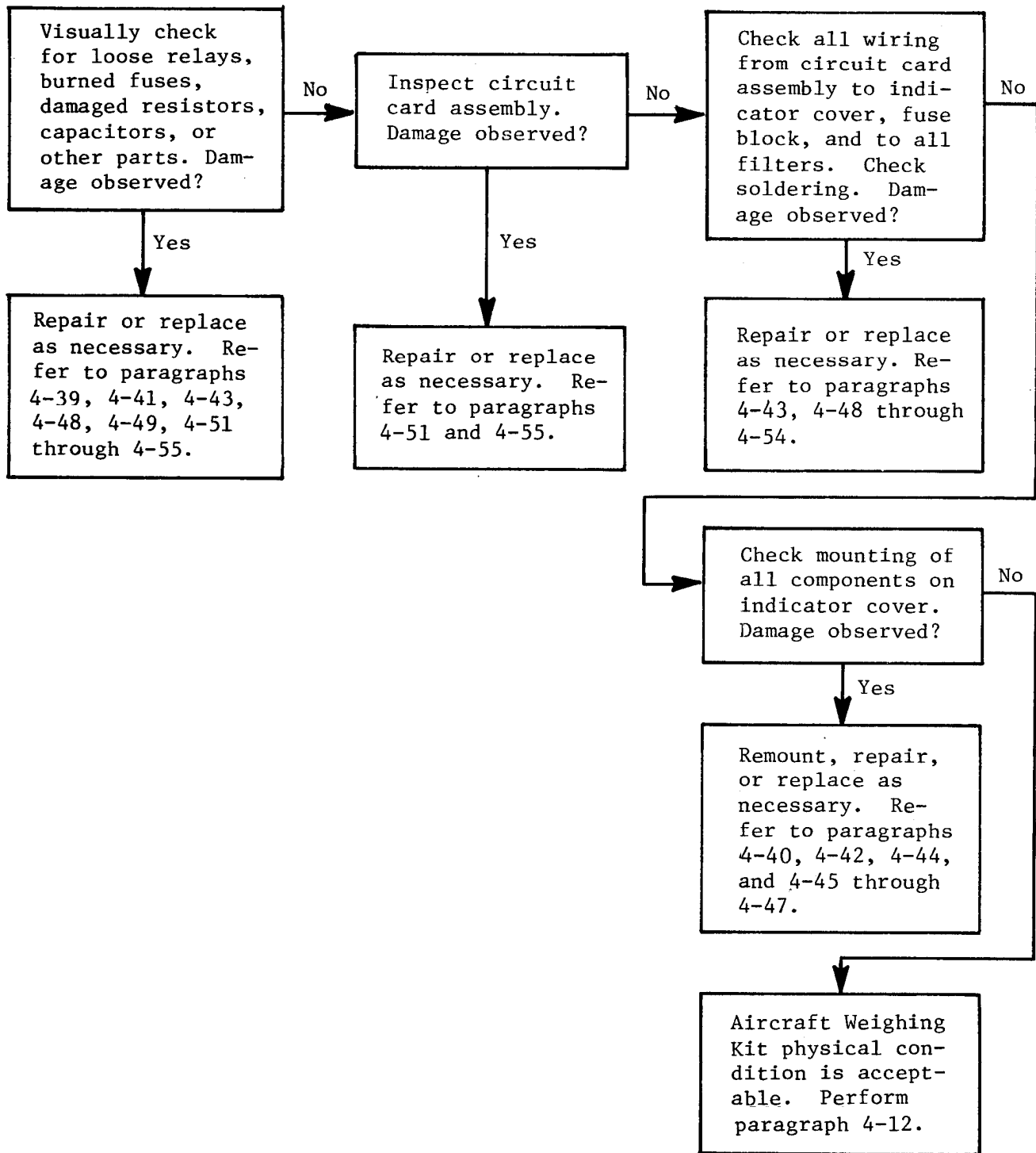

4-16. 115-VAC RECEPTACLE RESISTANCE FAULT ISOLATION.

APPLICABLE CONFIGURATION:

Aircraft Weighing Kit, Type A/S 37M-1

TOOLS/TEST AND SUPPORT EQUIPMENT:

Tool Kit: 35H Calibration Set
 NSN 6695-01-081-0705
 Load cell simulator, Revere Model R941
 or equivalent
 Multimeter
 Oscilloscope: Triggerable, dual beam,
 500 Kc minimum bandwidth
 Adjustable ac power supply 100-135 Vat,
 60 HZ
 Adjustable dc power supply 22-28 Vdc
 Adapter cable for load cell to simulator
 connection: Connector number
 GS02-14S-5P-001 attached to
 four 8" color-coded wires

PARTS :

As needed.

PERSONNEL REQUIRED:

35H Calibration and Repair Specialist

REFERENCES:

4-39. TASK 8 INDICATOR COVER REMOVAL/
 INSTALL.

EQUIPMENT CONDITION:

Power disconnected.
 Indicator cover removed from housing.

MATERIALS:

As needed.

Use caution when operating around
 unguarded 115 Vac energized circuits.

Performance:

NOTE

This initial set-up procedure is applicable to paragraphs 4-16 through 4-36.

SET UP INDICATOR, POWER SOURCES, AND TEST EQUIPMENT ACCORDING TO DIAGRAM.

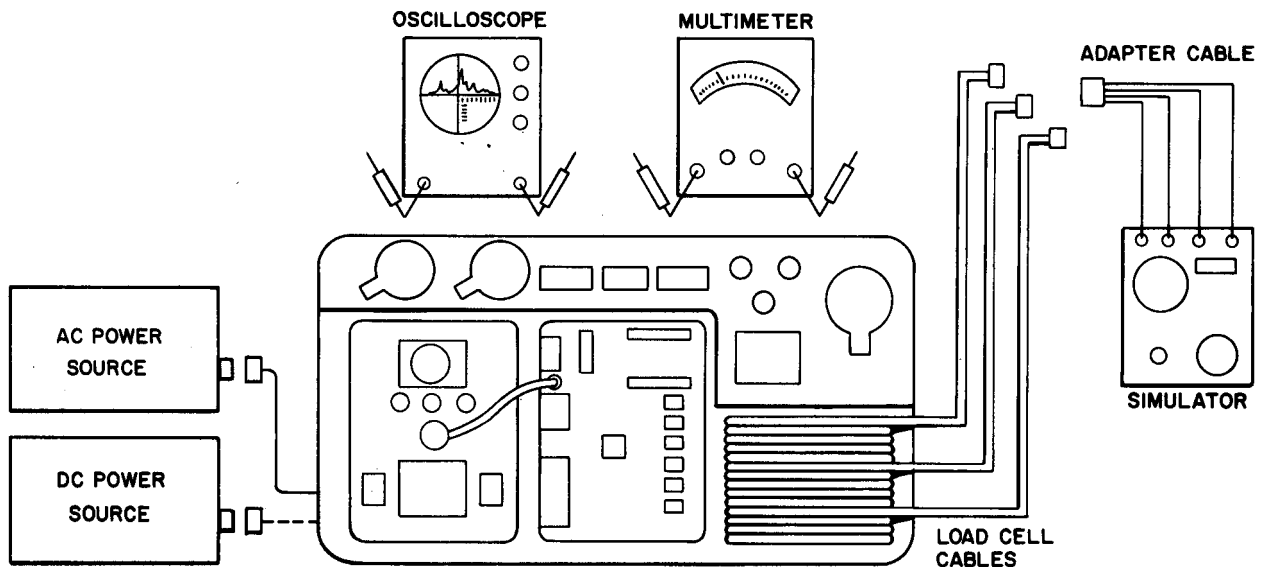

GO TO NEXT PAGE

4-16. 115-VAC RECEPTACLE RESISTANCE FAULT ISOLATION. (Cont)

4-16

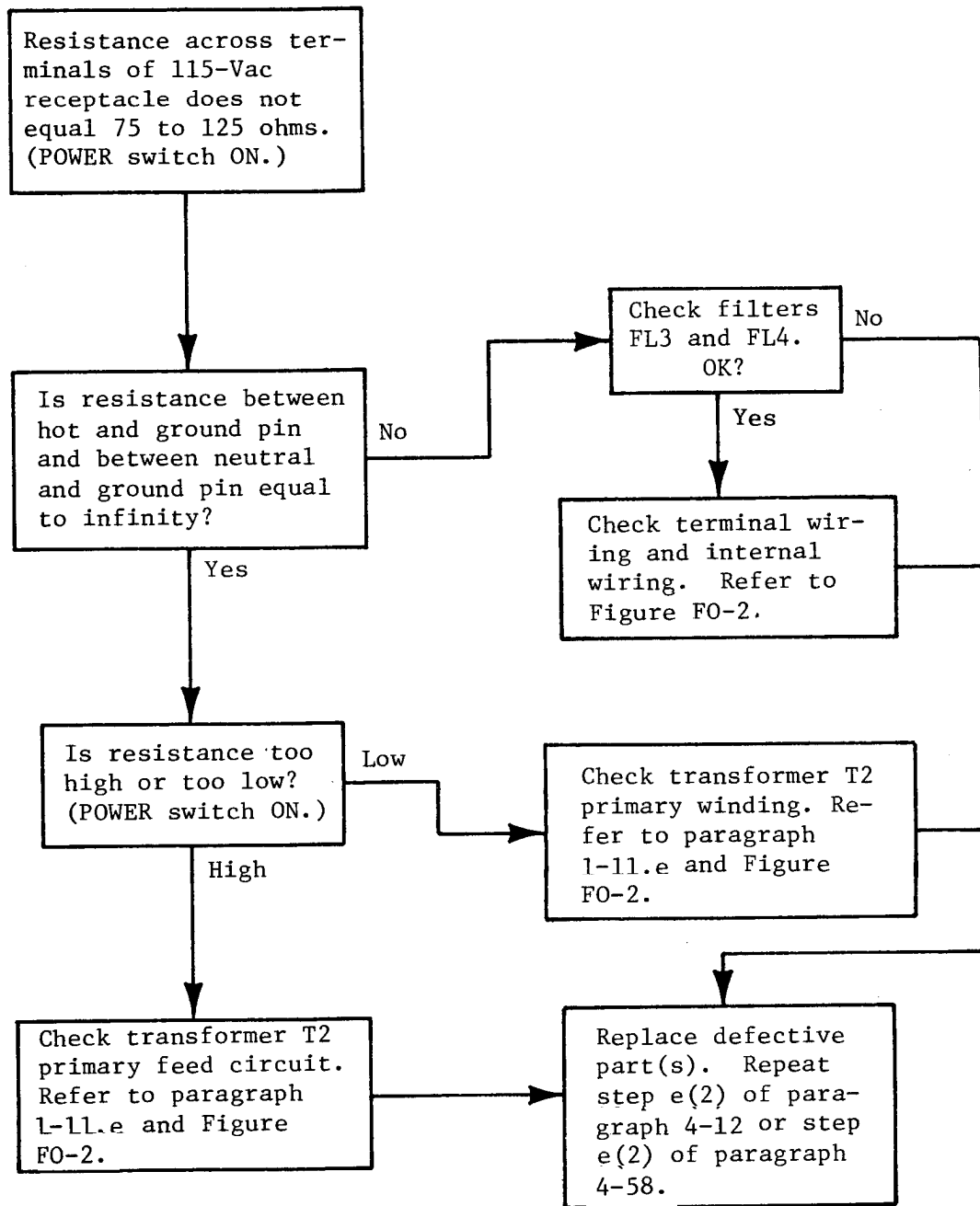

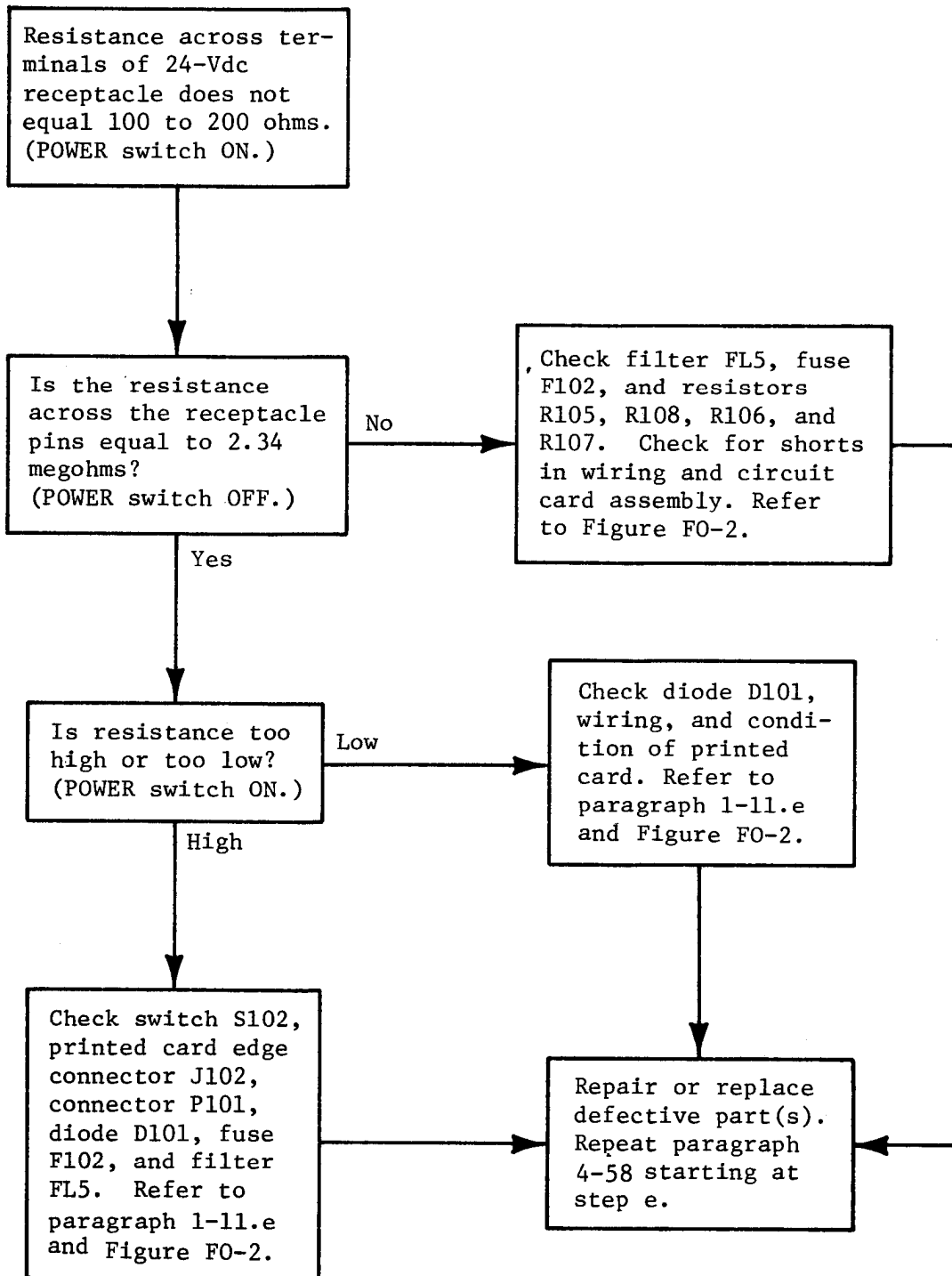

4-18. AC POWER SUPPLY FUNCTION FAULT ISOLATION.

4-18

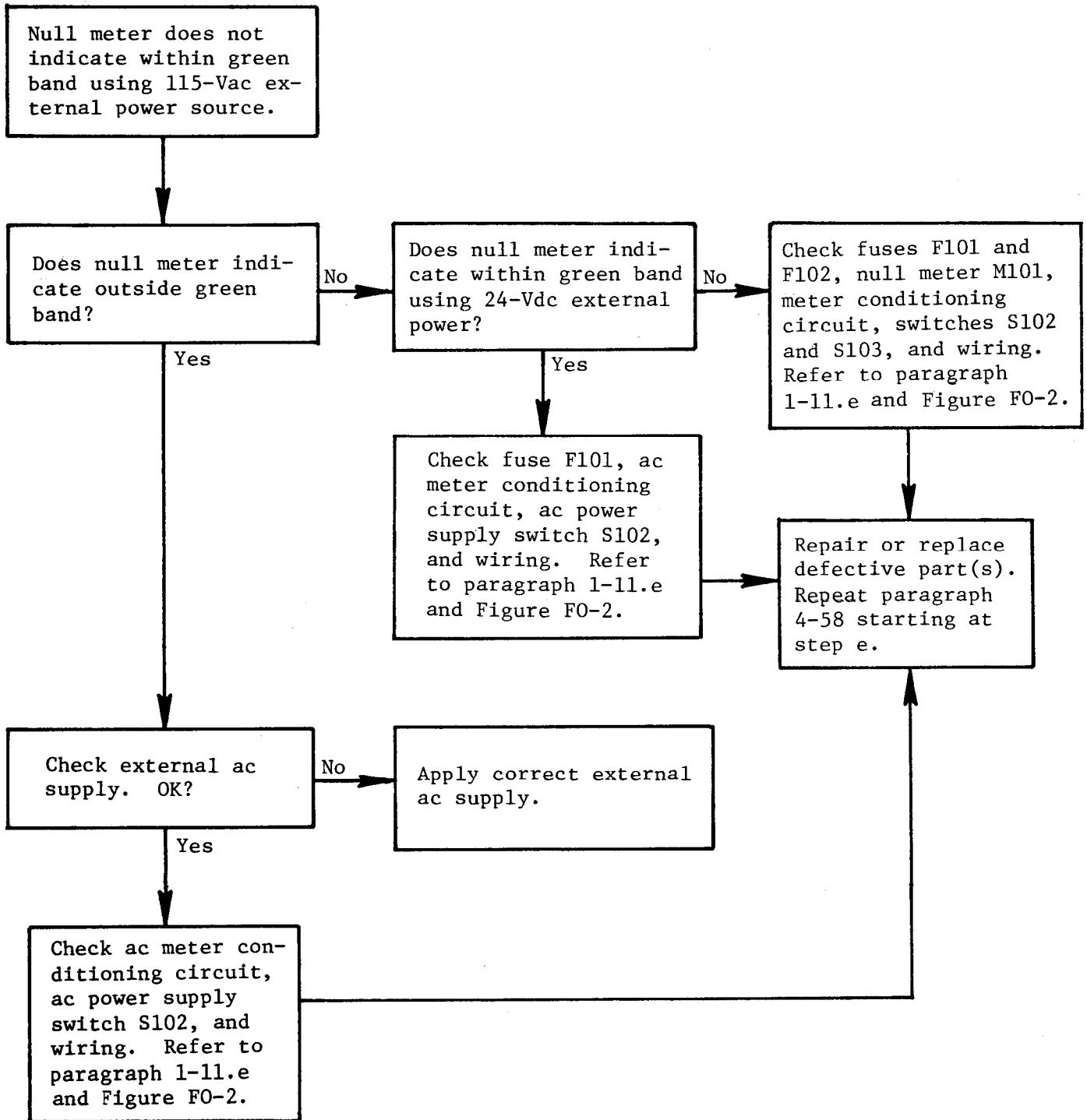

4-19. TEST POINT VOLTAGE CHECK FAULT ISOLATION.

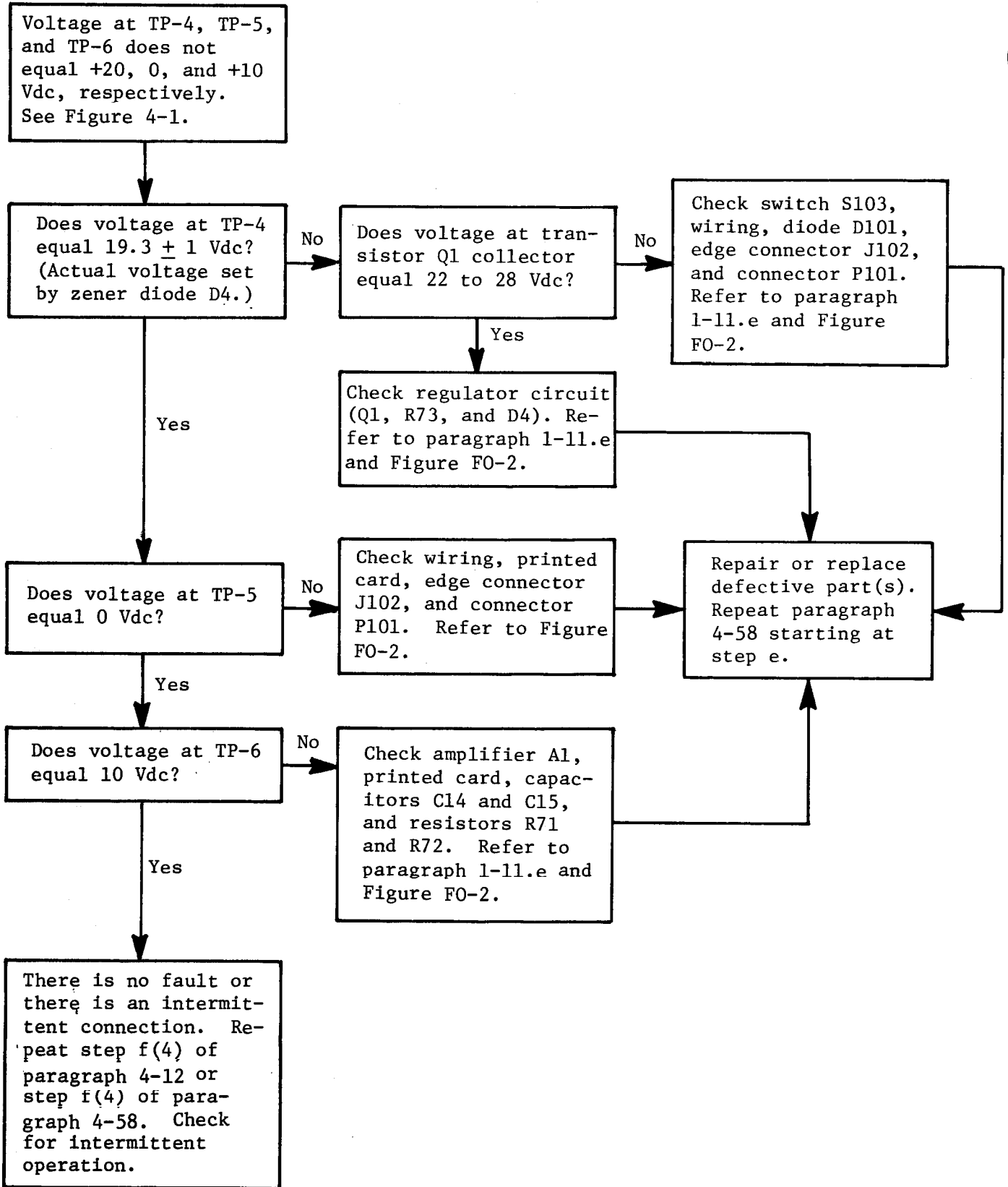

4-20. DC EXTERNAL POWER CHECK FAULT ISOLATION.

4-20

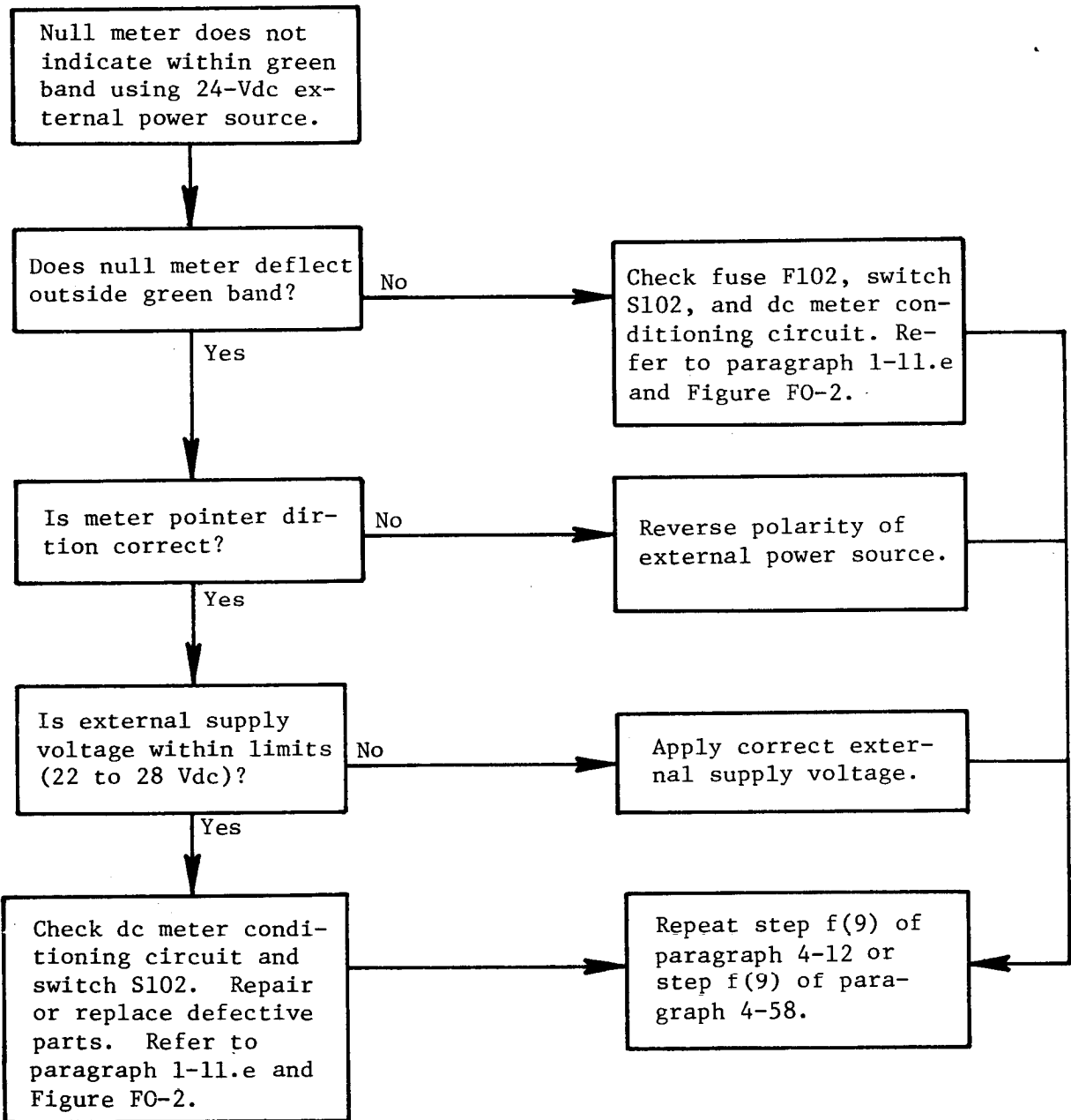

4-21. TP-4 STABLE VOLTAGE CHECK FAULT ISOLATION.

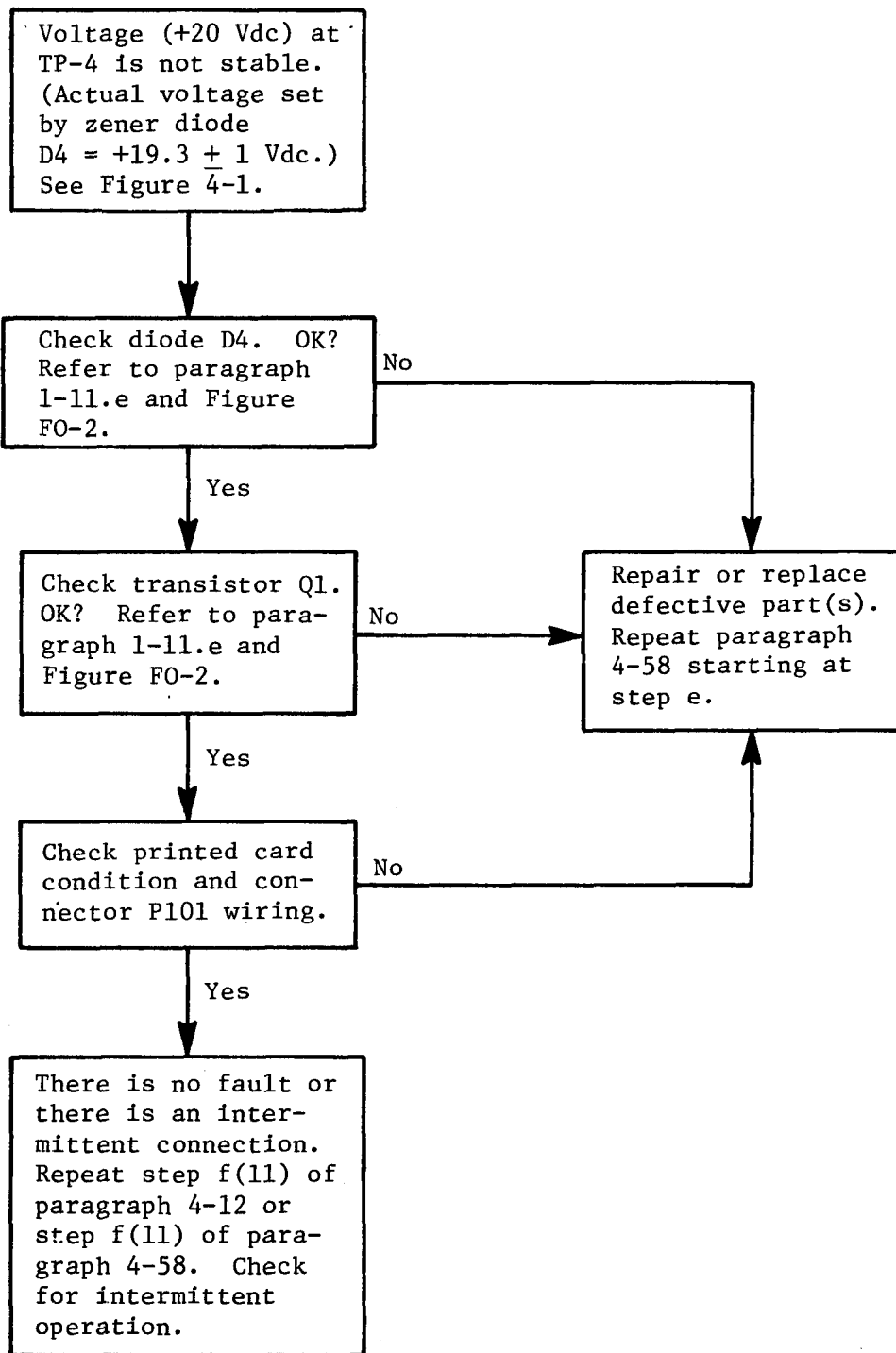

4-22. ADJUSTMENT OF ZERO SET CONTROLS FAULT ISOLATION.

4-22

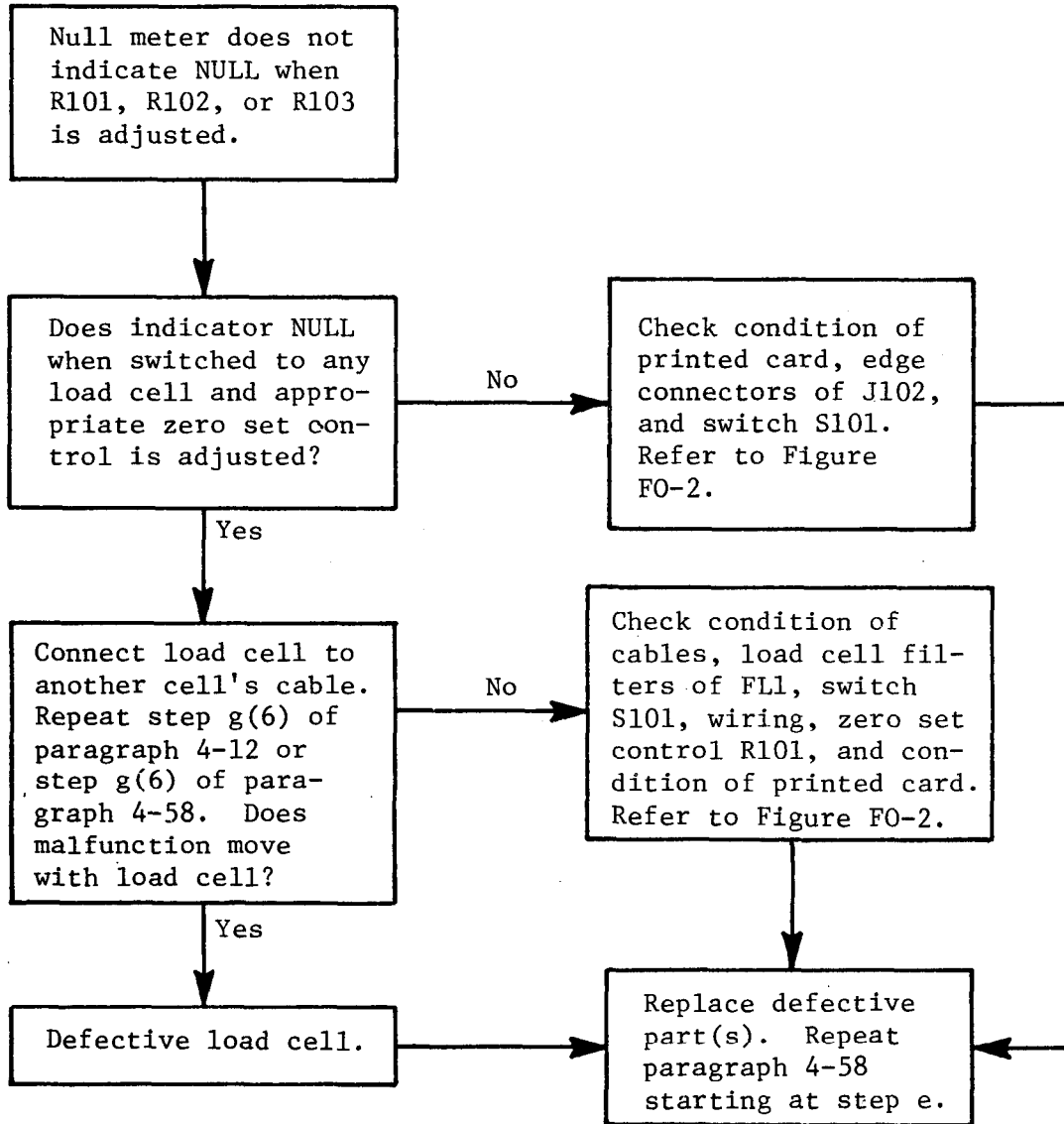

4-23. NULL METER FUNCTION CHECK FAULT ISOLATION.

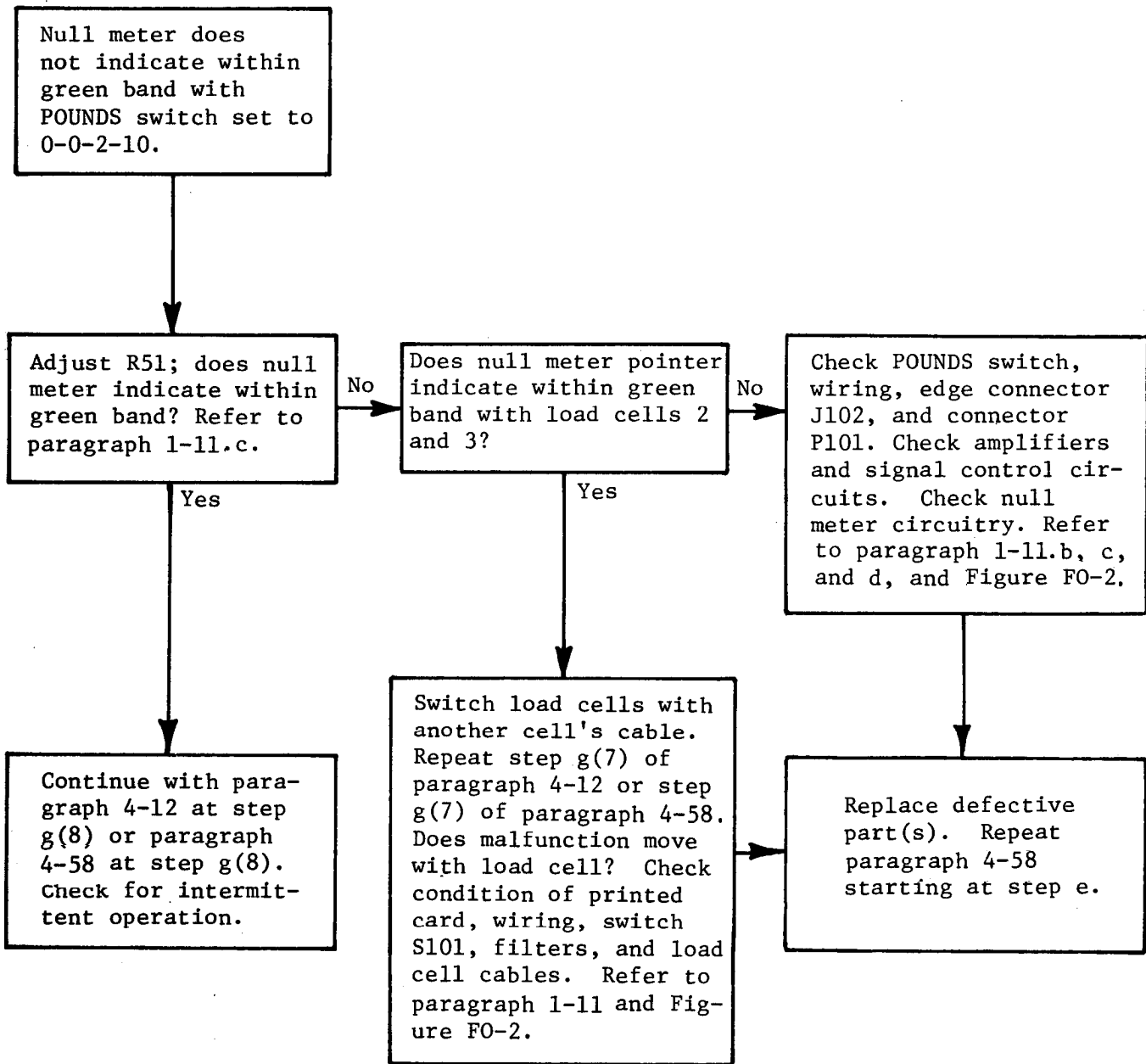

4-24. YELLOW BAND CHECK FAULT ISOLATION.

4-24

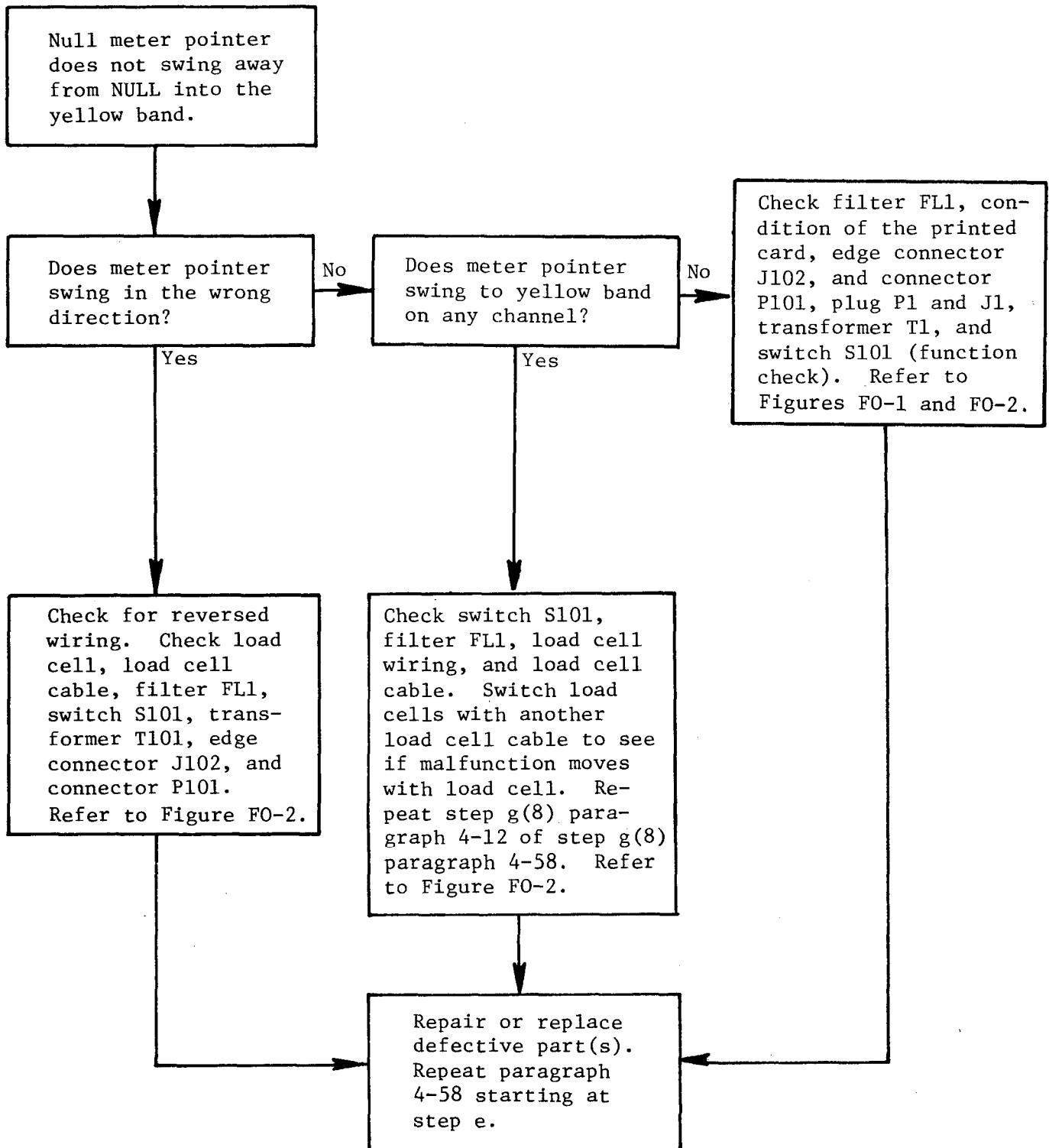

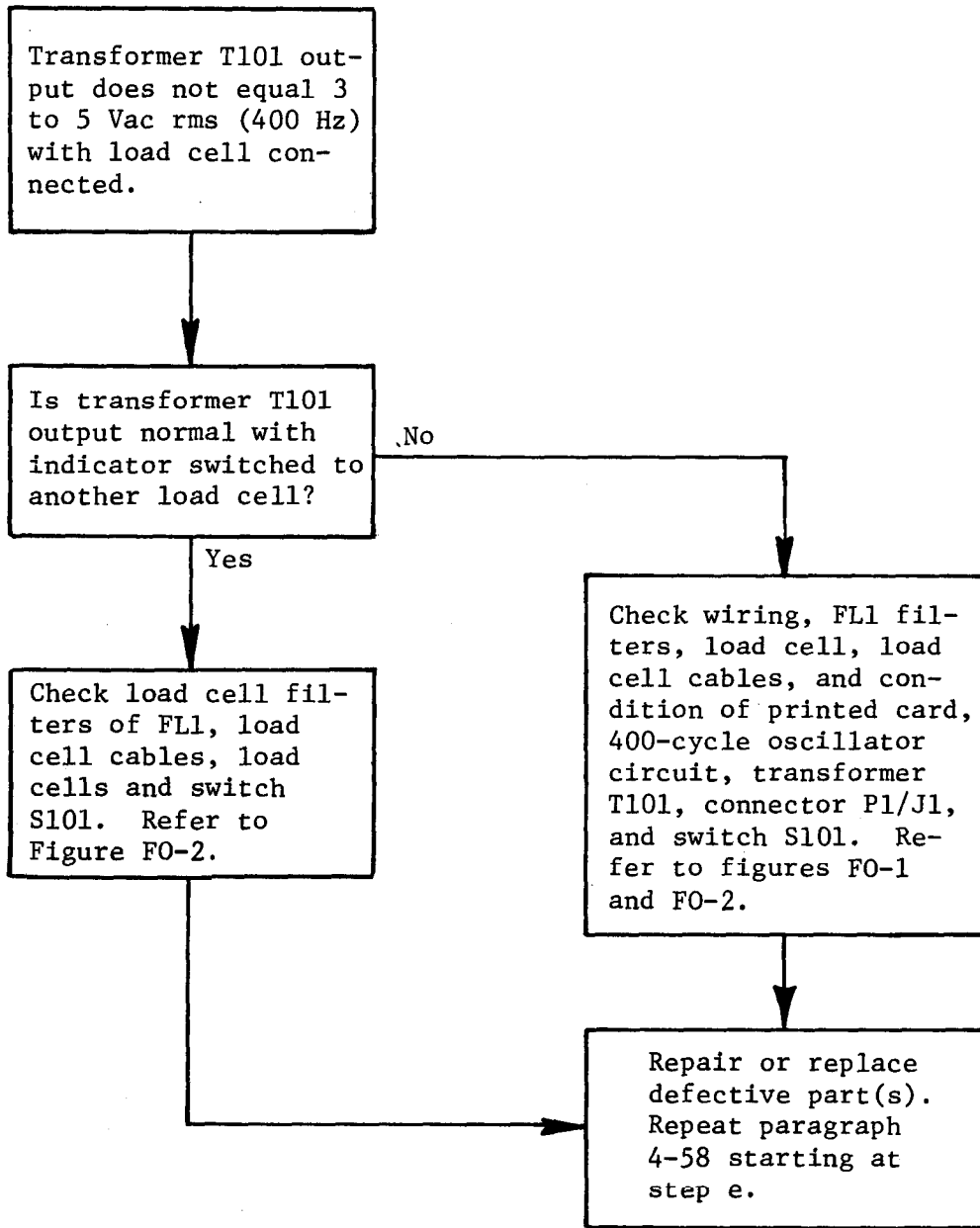

4-26. MINIMUM AMPLITUDE WAVESHAVE ADJUSTMENT FAULT ISOLATION.

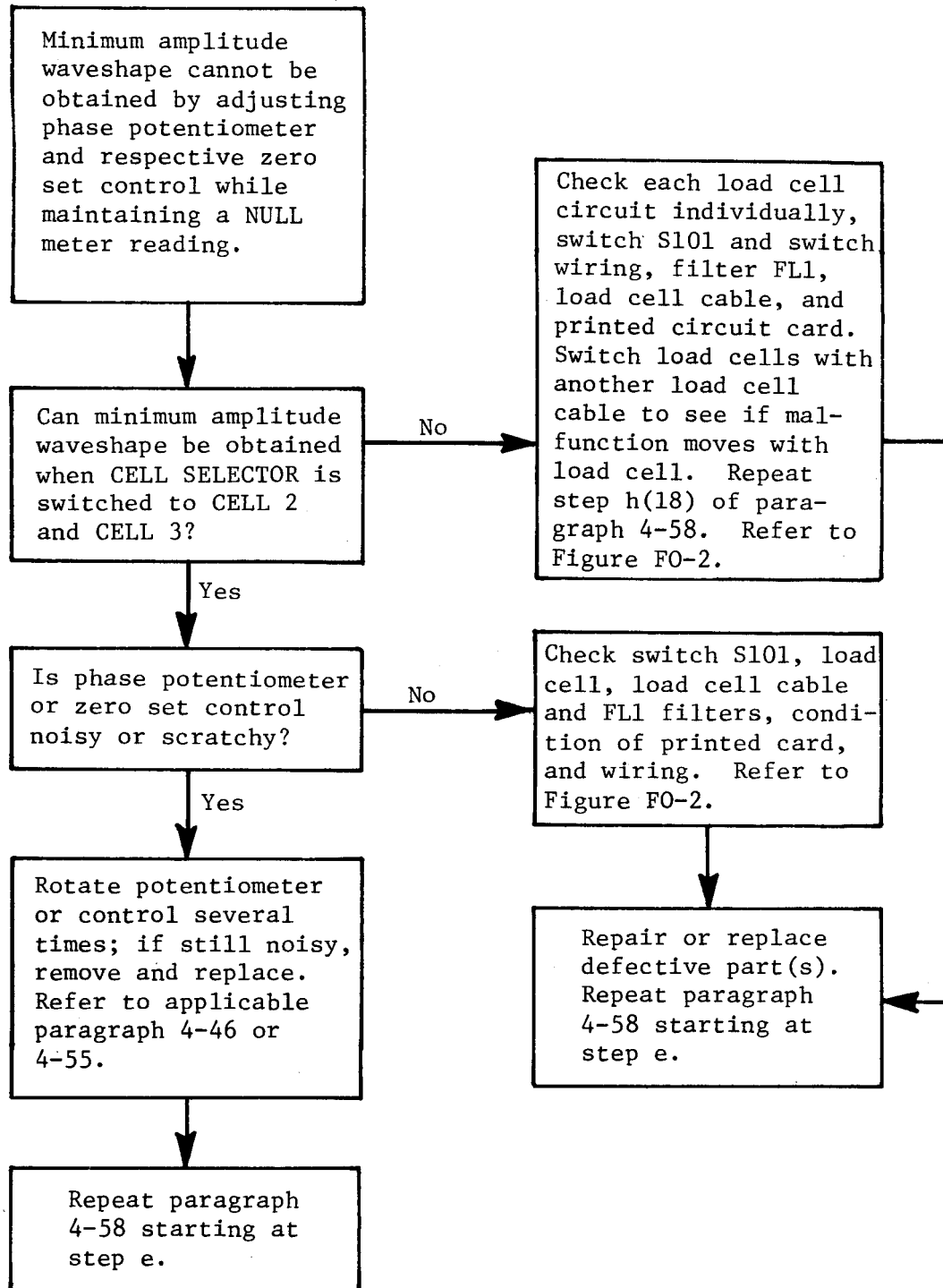

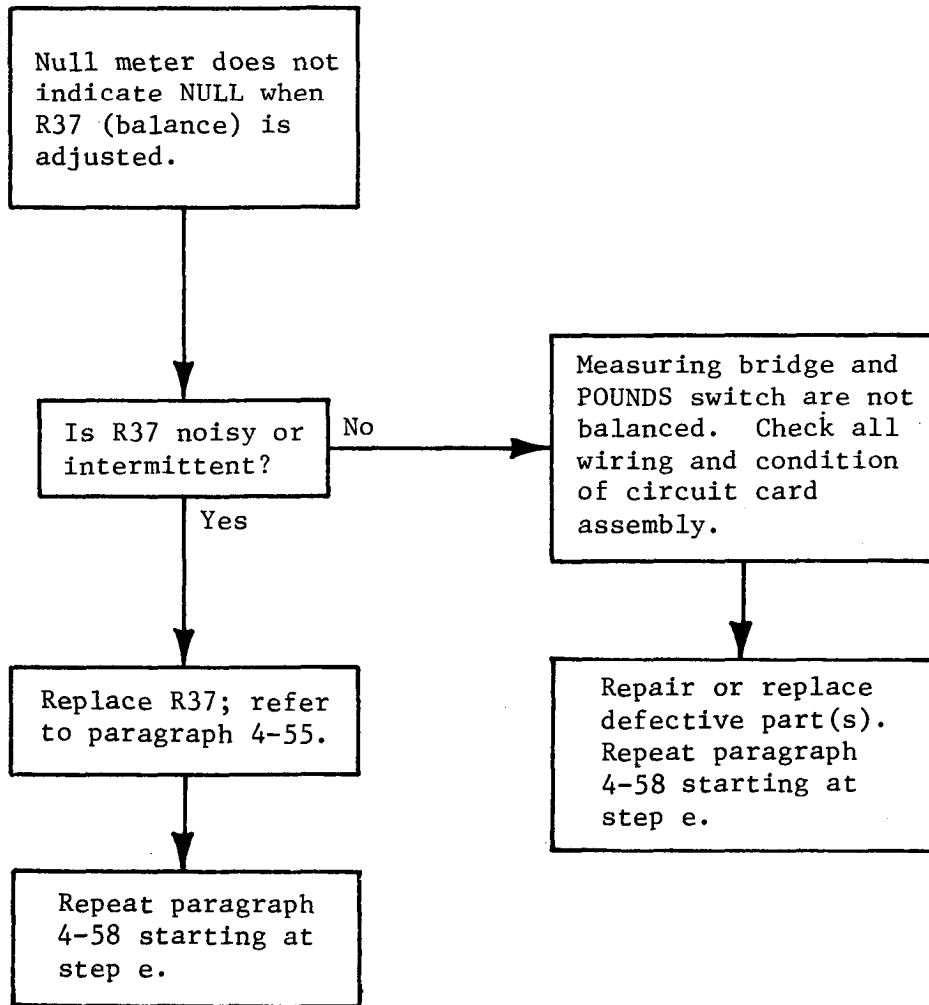

4-28. ADJUSTMENT OF R29 FAULT ISOLATION.

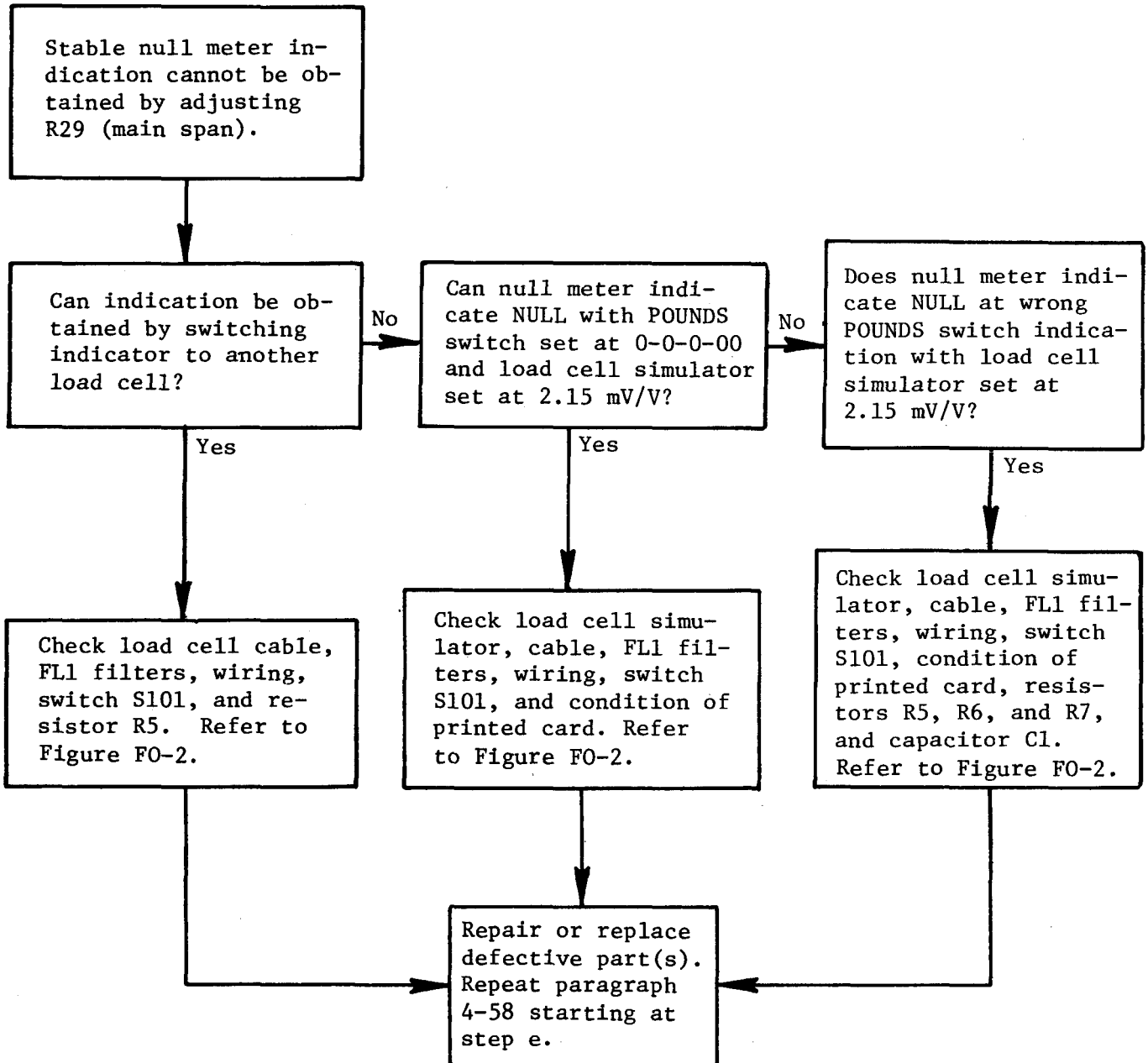

4-29. ADJUSTMENT OF R74 FAULT ISOLATION.

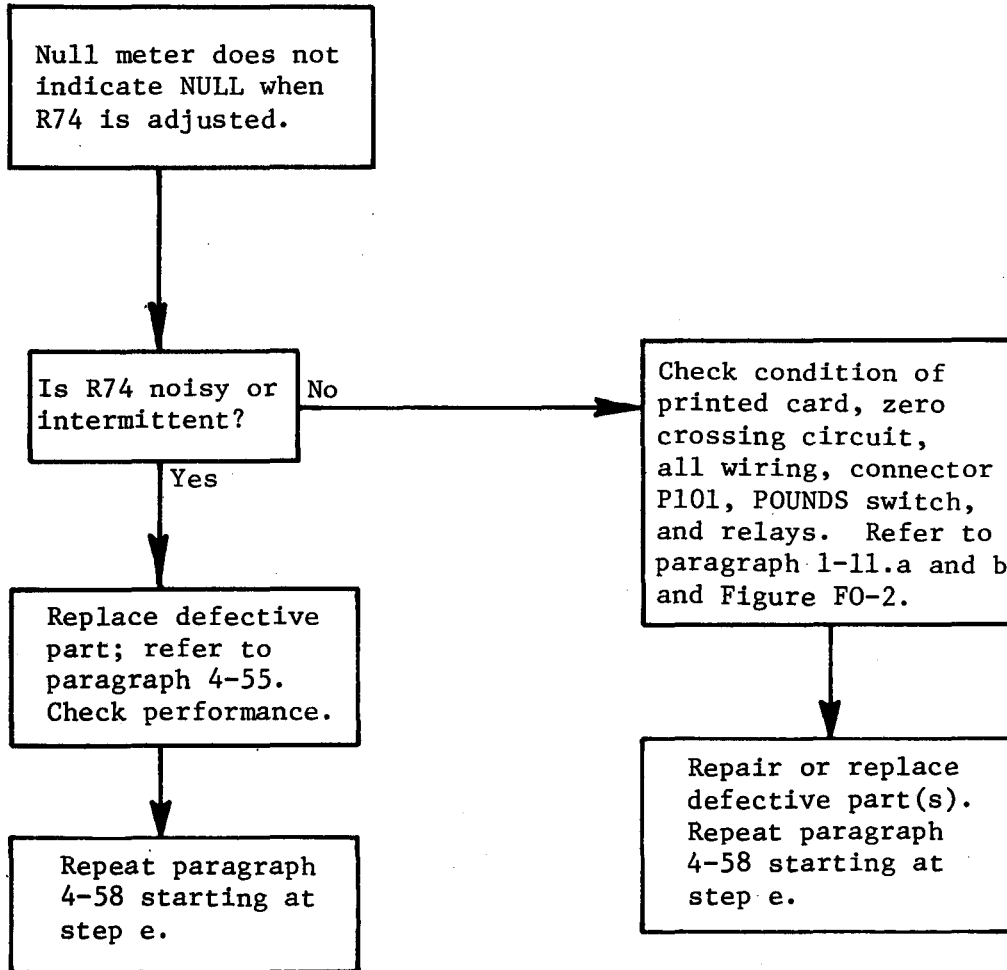

4-30. ADJUSTMENT OF R31 FAULT ISOLATION.

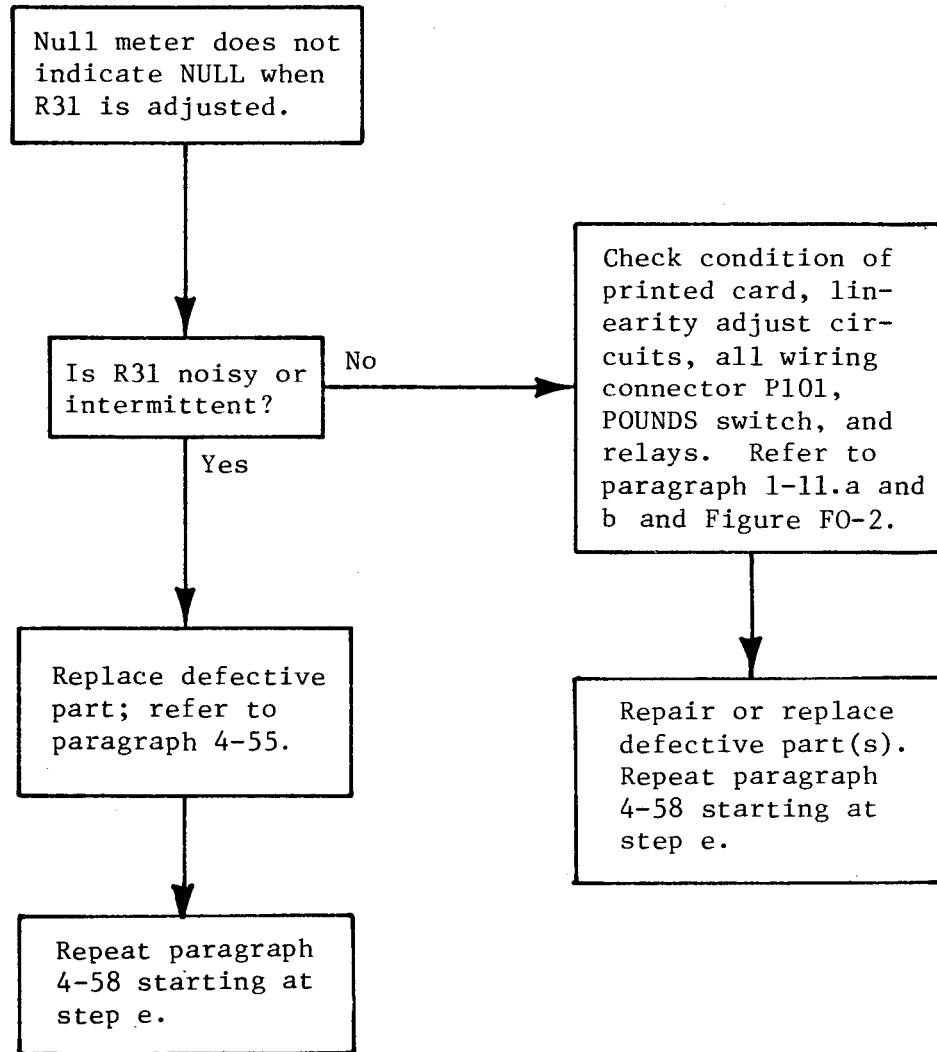

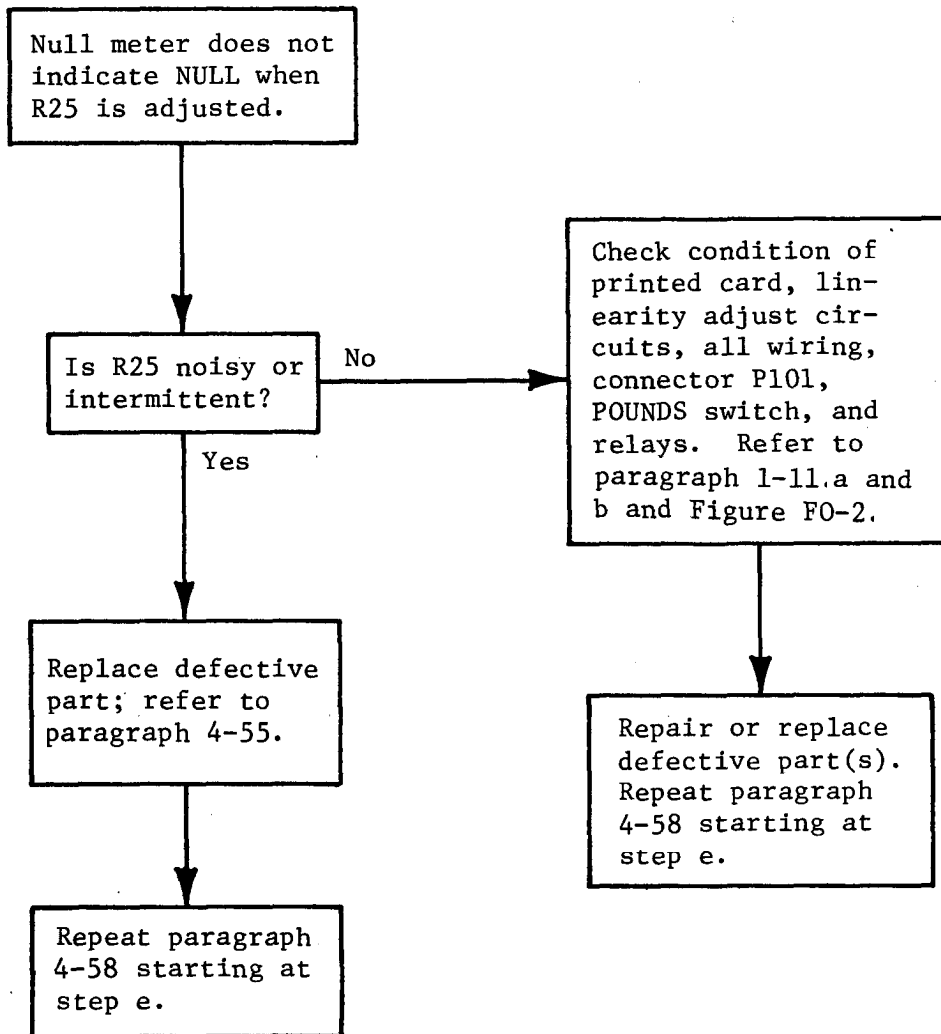

4-32. ADJUSTMENT OF R19 FAULT ISOLATION.

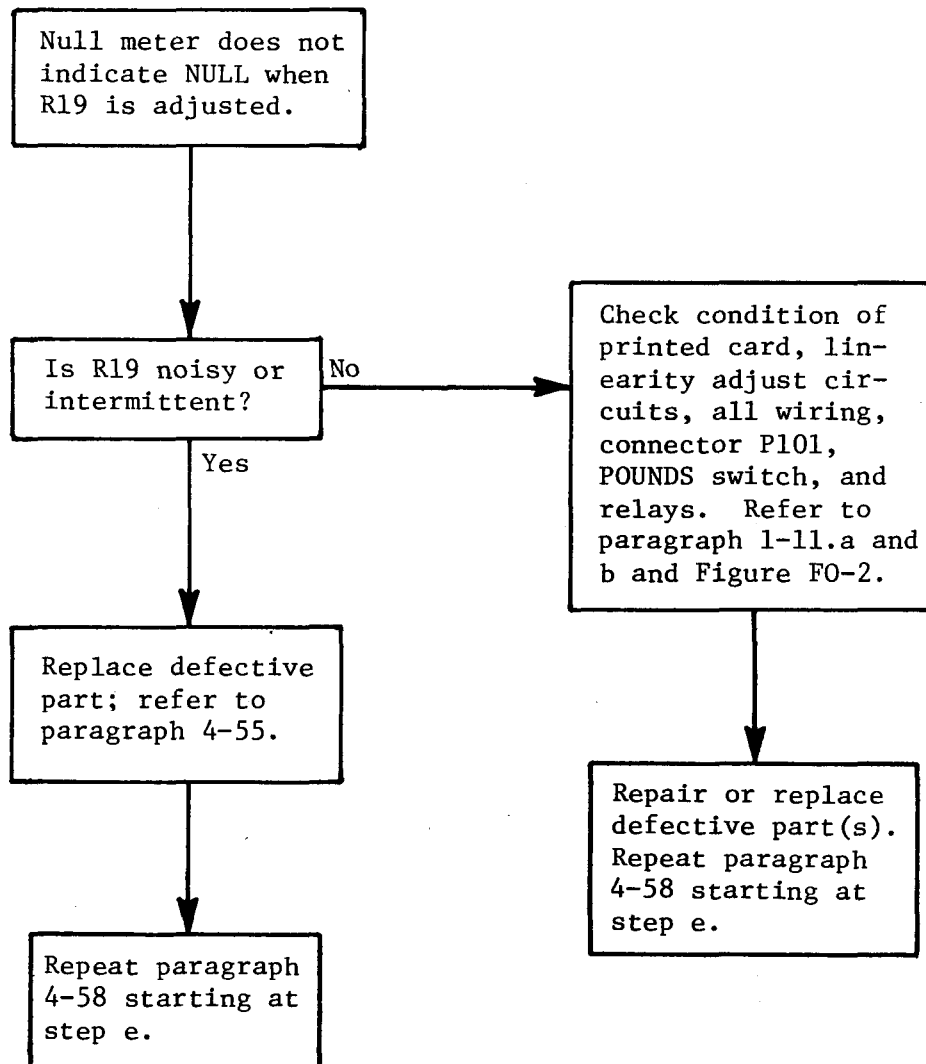

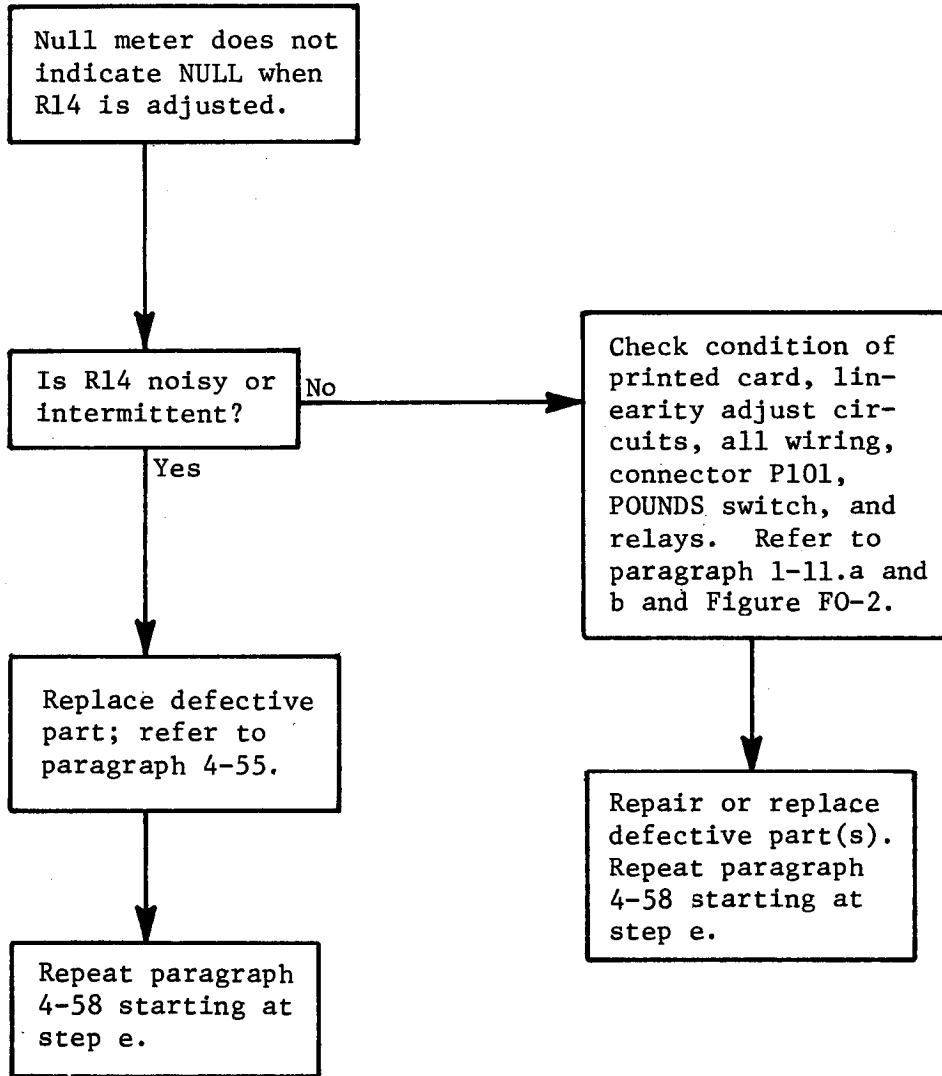

4-34 STABILITY OF CALIBRATION.

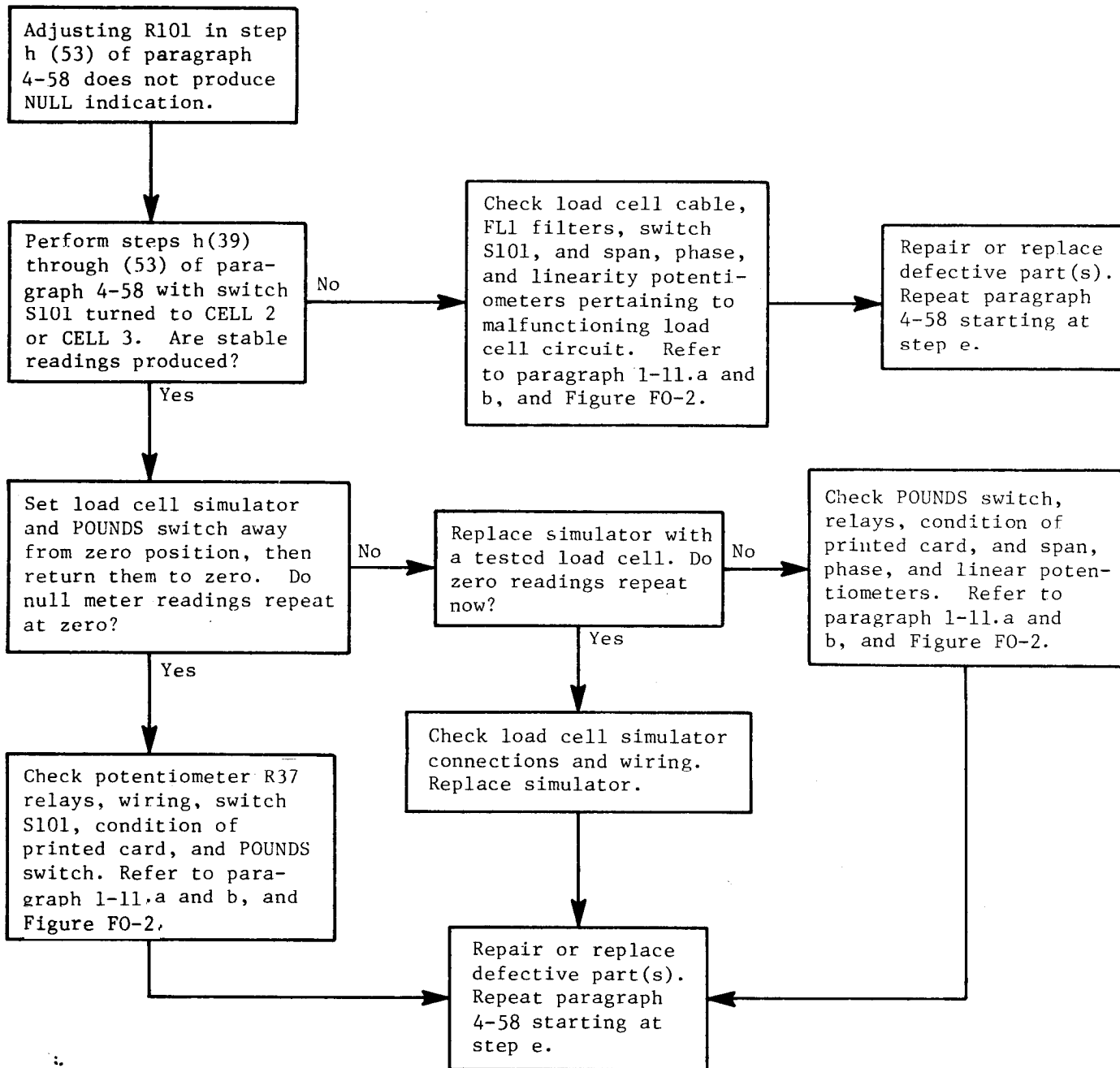

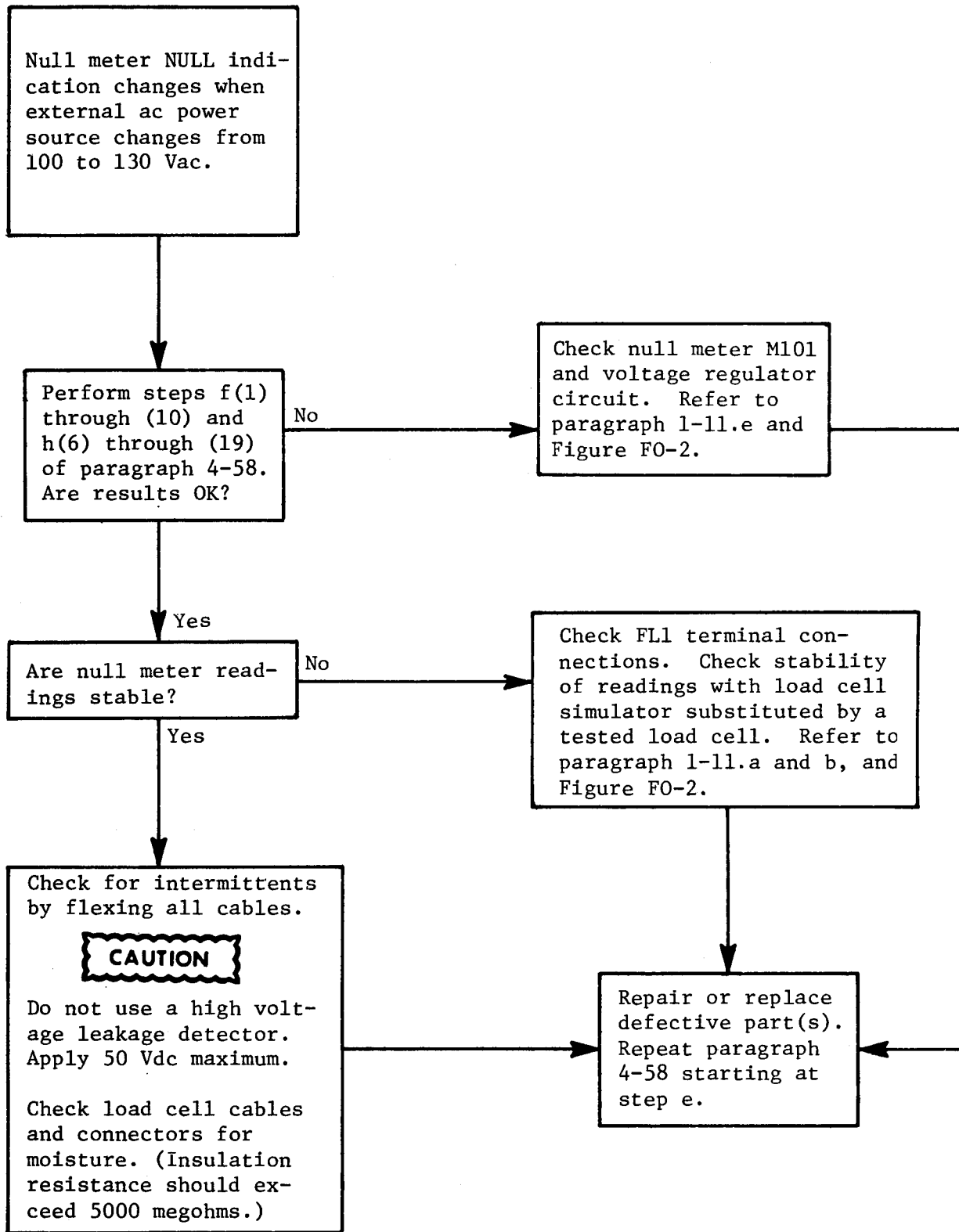

4-36. NULL INDICATION STABILITY (24 Vdc).

4-36

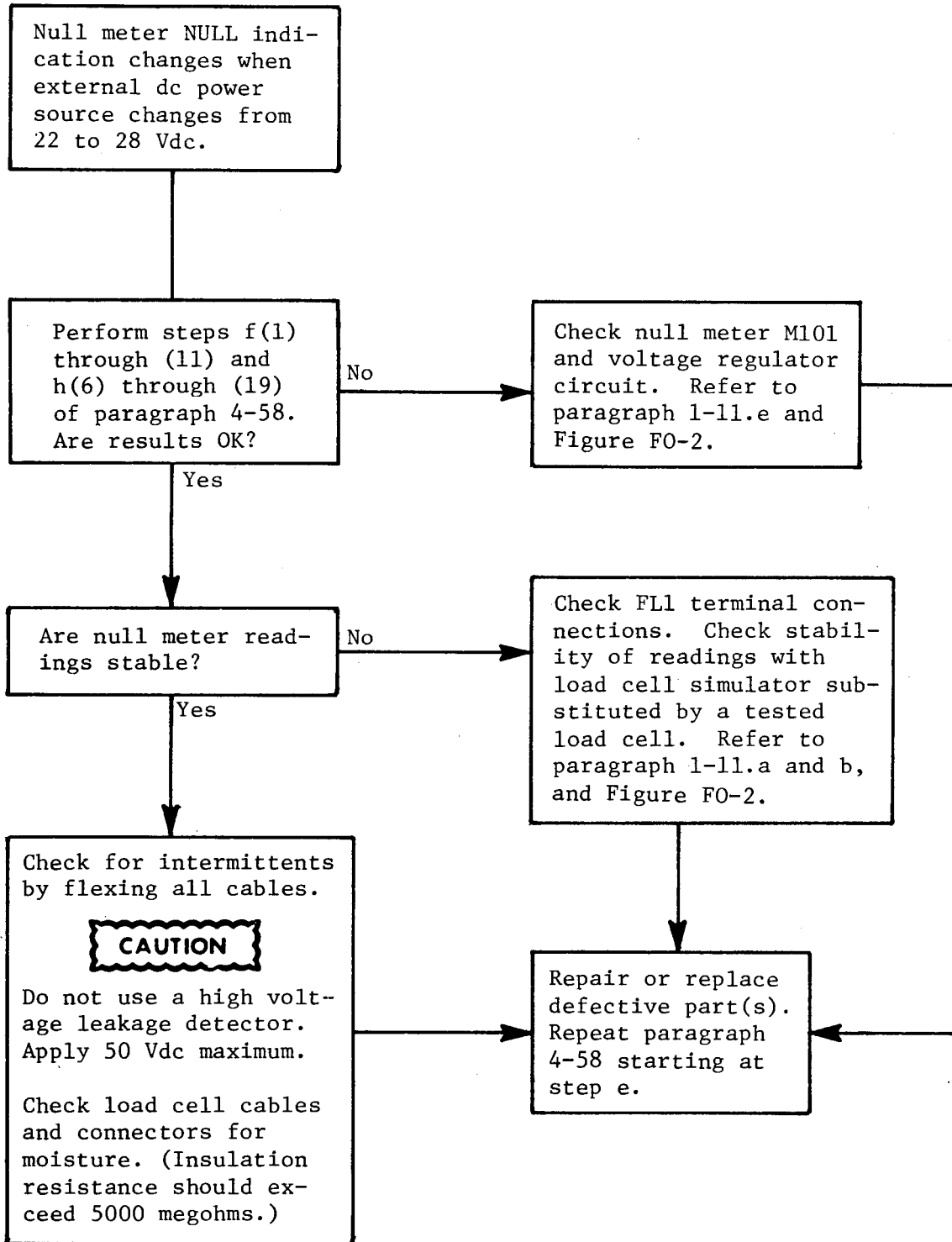

SECTION V - MAINTENANCE PROCEDURES

4-37. MAINTENANCE PROCEDURES - GENERAL.

4-37

When a maintenance procedure is required, it usually will involve removal of the part being repaired or replaced. Removal procedures are given only to the extent necessary to repair or replace authorized parts.

4-38. AIRCRAFT WEIGHING KIT MAINTENANCE.

4-38

Maintenance of the Weighing Kit consists of periodic recalibration. Calibration cannot be performed at AVIM level because a 50,000 pound (minimum) deadweight machine is required. A bench alignment procedure is provided so that 35H Calibration and Repair Specialist can check a kit for proper function and ability to be calibrated. The Aircraft Weighing Kit must be calibrated using a deadweight machine before it is returned to service.

4-39. INDICATOR COVER REMOVAL/INSTALL.

4-39

TASK 8

Initial Set-up:

APPLICABLE CONFIGURATION:

Aircraft Weighing Kit, Type A/S 37M-1

TOOLS/TEST AND SUPPORT EQUIPMENT:

Tool Kit: 35H Calibration Set
 NSN 6695-01-081-0705
 Tool Kit: Electrical Repairer,
 Army Aircraft, NSN 5180-00-323-4915

MATERIALS:

Cloth.

PERSONNEL REQUIRED

35H Calibration and Repair Specialist
 68F Aircraft Electrician

REFERENCES:

3-12. TASK 1 NULL METER FUNCTION CHECK.

EQUIPMENT CONDITION:

Power disconnected. Kit on workbench, cover open.

GO TO NEXT PAGE

4-39. INDICATOR COVER REMOVAL/INSTALL. (Cont)

4-39

Performance:

1. REMOVE INDICATOR COVER FROM INDICATOR HOUSING.

CAUTION

When removing cover be careful not to pull any wires loose.

- a. Loosen six captive screws (1) that fasten cover (2) to indicator housing (3).
 - b. Place cloth on Aircraft Weighing Kit to left of indicator panel, lift indicator cover (2) from housing (3), invert cover, turning it over and placing it on the protective material to the left of housing (internal wiring harness restricts movement in other directions).
2. INSTALL INDICATOR COVER ON INDICATOR HOUSING.
 - a. Lift indicator cover (2) from its rest position on scrap foam packing or soft cloth, turn cover over and place in position on indicator housing (3); ensure the wiring harness is inside the housing and that wires are not pinched.
 - b. Align six captive screws (1) in their mounting holes to the indicator housing (3).
 - c. Tighten captive screws (1) to fasten indicator cover (2) to indicator housing (3).
 - d. Perform NULL METER FUNCTION CHECK; refer to paragraph 3-12.

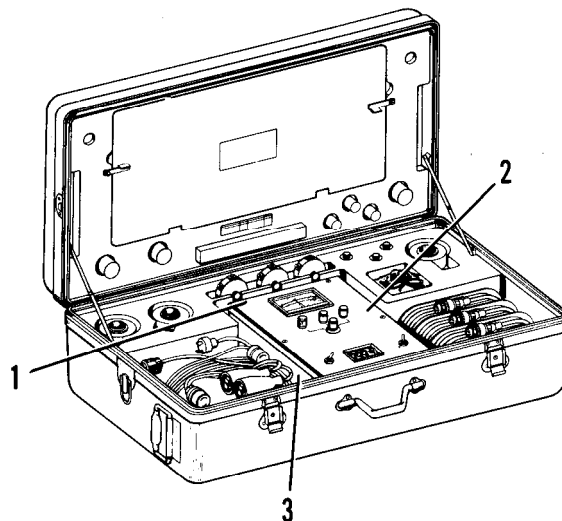

END OF TASK

TASK 9

Initial Set-up:

APPLICABLE CONFIGURATION:

Aircraft Weighing Kit, Type A/S 37M-1

PERSONNEL REQUIRED:

35H Calibration and Repair Specialist

TOOLS/TEST AND SUPPORT EQUIPMENT:Tool Kit: 35H Calibration Set
NSN 6695-01-081-0705REFERENCES:3-12. TASK 1 NULL METER FUNCTION
CHECK.
4-39. TASK 8 INDICATOR COVER
REMOVAL/INSTALL.MATERIALS:Resin Core Solder, QQS-571-SN60-
W-RA-P2, dia 0.031EQUIPMENT CONDITION:Power disconnected.
Kit on workbench. Indicator
cover removed from housing.PARTS :

Toggle switches, as required.

Performance:

NOTE

There are two toggle switches (S102,S103) on the indicator cover which are removable for replacement. This task covers removal of either one. POWER switch S102(1) is at the lower left corner of the cover; LOAD INDICATOR/BATTERY CHECK switch S103(2) is at the lower right corner.

1. REMOVE TOGGLE SWITCH FROM COVER.
 - a. Unsolder, tag, and remove wires from lugs on back of toggle switch (1 or 2) being removed.
 - b. Remove hex retaining nut (3) and washer (4) from the front panel side of the POWER switch (1); remove hex nut (5) and washer (6) from LOAD INDICATOR/BATTERY.CHECK switch (2).
 - c. Slide switch (1 or 2) out of indicator cover (7) from back side.

GO TO NEXT PAGE

4-40. TOGGLE SWITCH REMOVAL/REPLACEMENT. (Cont)**4 - 4 0**

2. REPLACE TOGGLE SWITCH ON INDICATOR COVER.

NOTE

LOAD INDICATOR/BATTERY CHECK switch S103(2) is a 3-position, On-Off-Momentary On switch; the momentary-on position is located at the bottom right corner of the cover (viewed from the front) and marked "BATTERY CHECK" on the panel. POWER switch S102(1) is a 3-position, On-Off-On switch, located at the bottom left corner. If both switches have been removed, ensure that replacements are located in the appropriate mounting holes before attaching hardware.

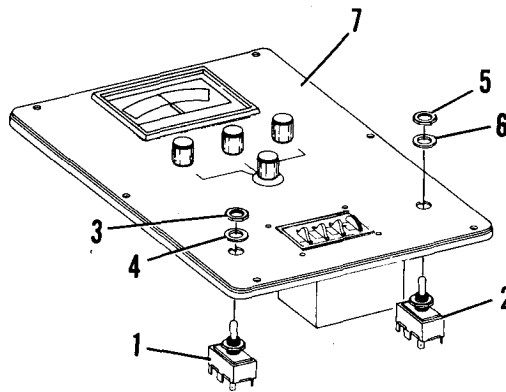

- a. Locate POWER switch S102(1) or LOAD INDICATOR/BATTERY CHECK switch S103(2) in appropriate mounting hole.
- b. Fasten switch to indicator cover (7) with appropriate washer and nut [(3) and (4) for POWER switch (1), (5) and (6) for LOAD INDICATOR/BATTERY CHECK switch (2)]; tighten nut securely.
- c. Attach switch wiring to switch, solder lugs according to tagged leads, solder wires in place, and remove tags.
- d. Install indicator cover (7) on housing; refer to paragraph 4-39.
- e. Perform NULL METER FUNCTION CHECK; refer to paragraph 3-12.

END OF TASK

TASK 10

Initial Set-up:

APPLICABLE CONFIGURATION:

Aircraft Weighing Kit, Type A/S 37M-1

TOOLS/TEST AND SUPPORT EQUIPMENT:

Tool Kit: 35H Calibration Set
 NSN 6695-01-081-0705
 Tool Kit: Electrical Repairer,
 Army Aircraft, NSN 5180-00-323-4915

PARTS :

1/4A, 1/2A fuses, as required.

PERSONNEL REQUIRED:

35H Calibration and Repair Specialist
 68F Aircraft Electrician

REFERENCES:

3-12. TASK 1 NULL METER FUNCTION
 CHECK.
 4-39. TASK 8 INDICATOR COVER
 REMOVAL/INSTALL .

EQUIPMENT CONDITION:

Power disconnected.
 Kit on workbench.
 Indicator cover removed from housing.

Performance:

1. REMOVE AC AND DC FUSES.
 - a. Visually check 1/4A ac fuse F101(1) and 1/2A dc fuse F102(2) to see if either needs to be replaced.
 - b. Remove fuses (1,2), as required.
2. REPLACE AC AND DC FUSES.
 - a. Replace with new fuses of correct value as stated in APPENDIX C, Figure C-3.

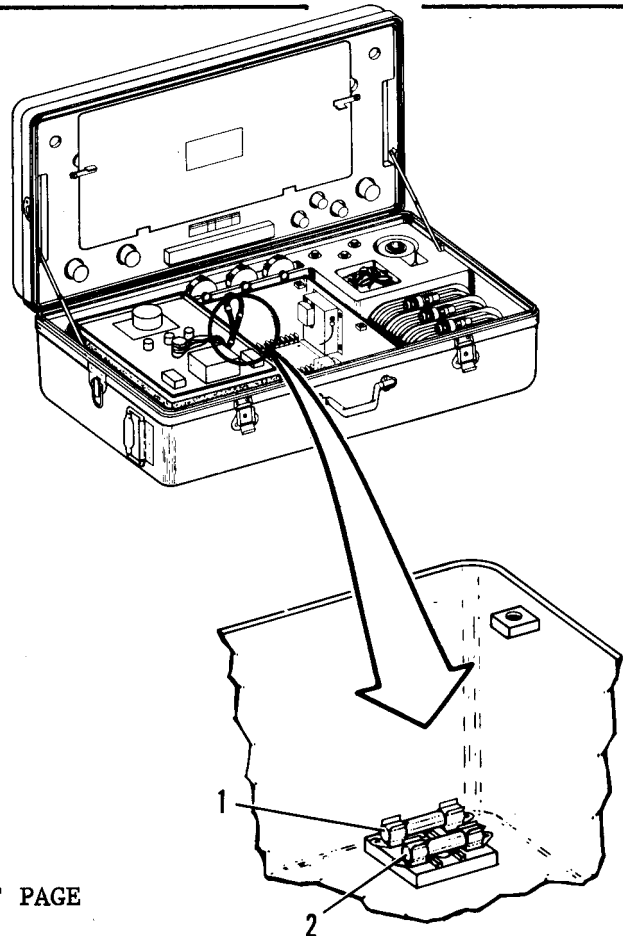

GO TO NEXT PAGE

4-41. FUSE REMOVAL/REPLACEMENT. (Cont)

4-41

- b. Install indicator cover (3); refer to paragraph 4-39.)
- c. Perform NULL METER FUNCTION CHECK according to paragraph 3-12.

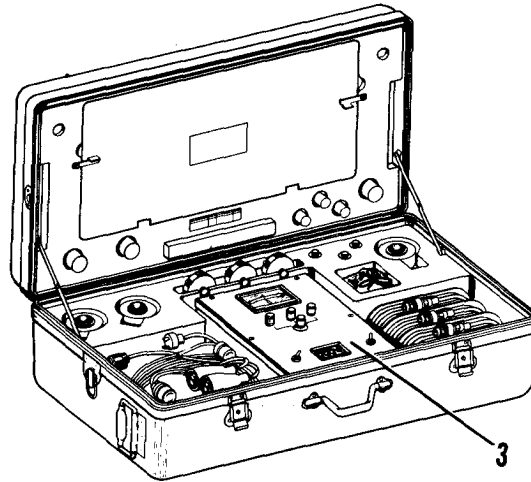

END OF TASK

TASK 11

Initial Set-up:

APPLICABLE CONFIGURATION:

Aircraft Weighing Kit, Type A/S 37M-1

TOOLS/TEST AND SUPPORT EQUIPMENT:

Tool Kit: 35H Calibration Set
NSN 6695-01-081-0705

MATERIALS:

Loctite.

PARTS :

Null meter as required.

PERSONNEL REQUIRED:

35H Calibration and Repair Specialist

REFERENCES:

3-12. TASK 1 NULL METER FUNCTION CHECK.
4-39. TASK 8 INDICATOR COVER REMOVAL/INSTALL .

EQUIPMENT CONDITION:

Power disconnected.
Kit on workbench.
Indicator cover removed from indicator housing.

Performance:

1. REMOVE NULL METER FROM INDICATOR COVER.
 - a. Tag two wires (1) fastened to terminal posts (2) at rear of null meter (3).
 - b. Remove two nuts (4) and washers (5) from terminal posts at rear of null meter and lift wire terminals off posts; set wires aside.
 - c. Remove two clamp screws (6), and remove two nuts (7), two lock washers (8), and two flat washers (9) from studs (10) on null meter (3).

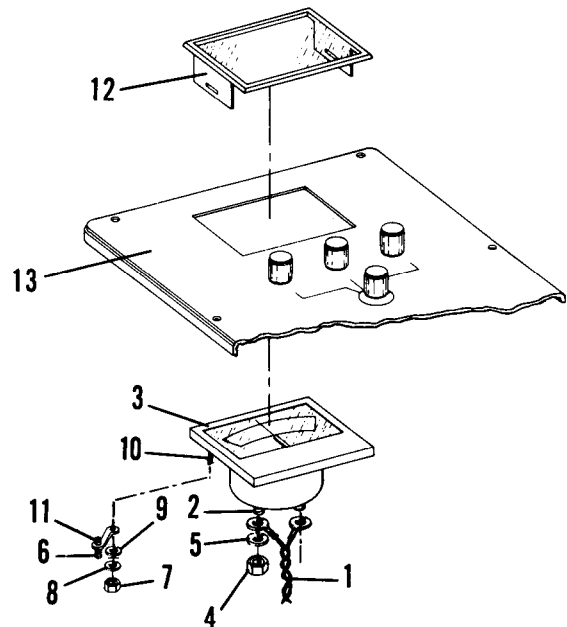

GO TO NEXT PAGE

4-42. NULL METER REMOVAL/REPLACEMENT. (Cont)

4-42

- d. Support the bezel (12) in one hand while removing clamps (11) out of slots in bezel (12). Remove meter (3) from back of indicator cover (13).
 - e. Remove null meter (3) from back of indicator cover (13).
2. REPLACE NULL METER IN INDICATOR COVER.
- a. Insert bezel (12) from front of indicator cover (13).
 - b. Position null meter (3) into indicator cover (13) from the rear.
 - c* Insert two clamps (11) into slots closest to bezel (12) and onto studs (10). Secure to null meter (3) with two flat washers (9), two lock washers (8), and nuts (7). Install clamp screws (6) fingertight plus 1/2 turn to secure null meter to indicator cover (13). Apply Loctite No. 222 or equivalent to keep screws in place.
 - d. Attach two tagged wires to null meter terminal posts (2) with two washers (5) and nuts (4) furnished with null meter.
 - e. Install indicator cover (13) according to paragraph 4-39.
 - f. Perform NULL METER FUNCTION CHECK according to paragraph 3-12.

END OF TASK

4-43. POWER RECEPTACLES REMOVAL/REPLACEMENT.

4-43

TASK 12

Initial Set-up:

APPLICABLE CONFIGURATION:

Aircraft Weighing Kit, Type A/S 37M-1

TOOLS/TEST AND SUPPORT EQUIPMENT:

Tool Kit: 35H Calibration Set
NSN 6695-01-081-0705

PARTS :

Receptacles, as required.

PERSONNEL REQUIRED:

35H Calibration and Repair Specialist

REFERENCES :

4-39. TASK 8 INDICATOR COVER REMOVAL/INSTALL .

4-51. TASK 20 CIRCUIT CARD ASSEMBLY REMOVAL/INSTALL .

EQUIPMENT CONDITION:

Power disconnected.
Indicator cover removed from housing.
Circuit card assembly removed from housing.

Performance:



When removing indicator cover be careful not to pull any wires loose.

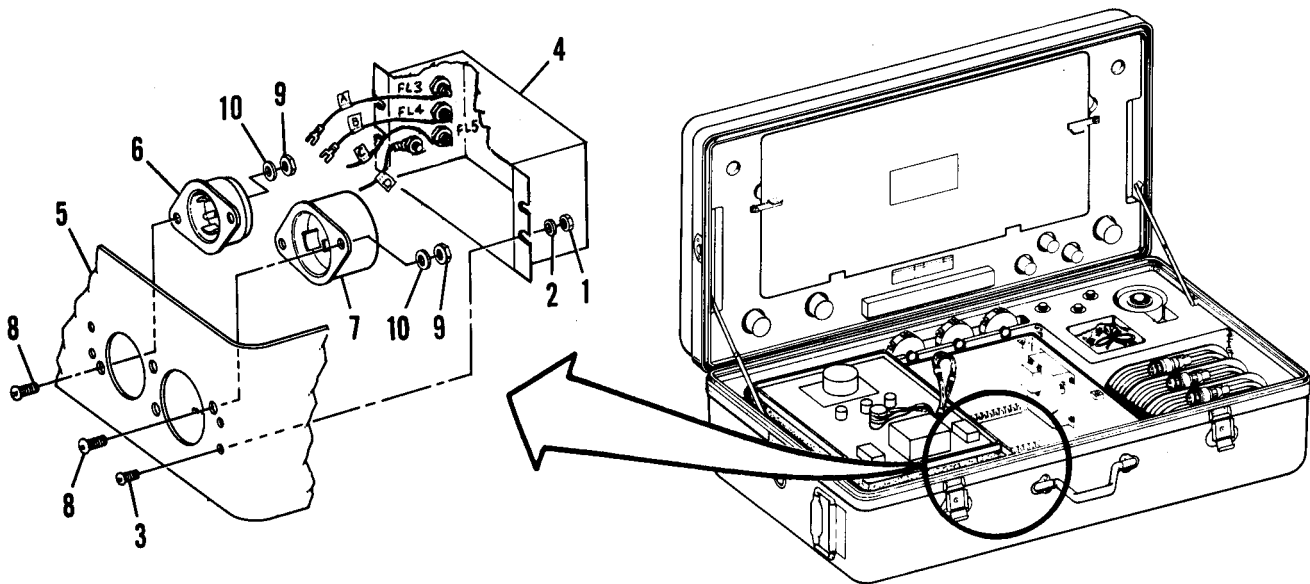

GO TO NEXT PAGE

4-43. POWER RECEPTACLES REMOVAL/REPLACEMENT. (Cont)

4-43

1. REMOVE AC AND DC POWER RECEPTACLES.
 - a. Remove four nuts (1), washers (2), and screws (3) that fasten RFI shield (4) to housing.
 - b. Remove RFI shield (4) from indicator housing (5).
 - c. Tag and remove the wires from the appropriate receptacle.
 - d. To remove either receptacle (6 and 7), remove two screws (8), nuts (9), and lockwashers (10) that fasten receptacle to indicator housing (5).
 - e. Remove receptacle from inside of indicator housing.
2. REPLACE AC AND DC POWER RECEPTACLES.
 - a. Locate receptacle (6 or 7) over receptacle access hole in indicator housing (5).
 - b. Line up mounting holes between receptacle and housing; insert two screws (8) through indicator housing (5) and receptacle (6 or 7) and fasten with two washers (10) and nuts (9).
 - c. Replace wires on appropriate receptacle terminals and remove tags.
 - d. Install RFI shield (4) and fasten in place with four sets of screws (3), washers (2), and nuts (1).
 - e. Perform step 2 of CIRCUIT CARD ASSEMBLY, AMPLIFIER, OSCILLATOR REMOVAL/REPLACEMENT according to paragraph 4-51.

END OF TASK

4-44. TERMINAL BOARD REMOVAL/REPLACEMENT.

TASK 13

Initial Set-up:

APPLICABLE CONFIGURATION:

Aircraft Weighing Kit, Type A/S 37M-1

TOOLS/TEST AND SUPPORT EQUIPMENT:

Tool Kit: 35H Calibration Set,
NSN 6695-01-081-0705

MATERIALS:

Resin Core Solder, QQS-571-SN60-
W-RA-P2, dia. 0.031

PARTS :

Terminal board, as required.

PERSONNEL REQUIRED:

35H Calibration and Repair Specialist

REFERENCES:

- 3-12. TASK 1 NULL METER FUNCTION CHECK.
- 4-39. TASK 8 INDICATOR COVER REMOVAL/
INSTALL.
- 4-58. TASK 27 BENCH ALIGNMENT.

EQUIPMENT CONDITION:

Power disconnected.
Indicator cover removed from housing.

Performance:

1. REMOVE TERMINAL BOARD FROM INDICATOR COVER.
 - a. Unsolder, tag, and remove wires and components attached to four lugs on terminal board TB101 (1).
 - b. Make a note of terminal board location/position and remove nut (2) and washer (3) that fasten terminal board (1) and one side of thumbwheel switch shield (4) to indicator cover (5).
 - c. Remove wire lug (6) and terminal board (1) from shield mounting stud.

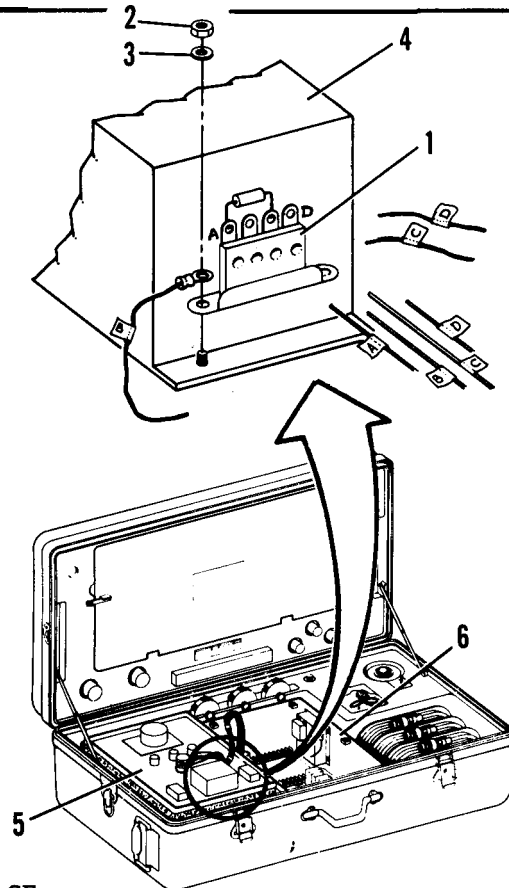

GO TO NEXT PAGE

4-44. TERMINAL BOARD REMOVAL/REPLACEMENT. (Cont)

4-44

2. REPLACE TERMINAL BOARD ON INDICATOR COVER.
 - a. Properly position terminal board (1) on shield mounting stud of thumbwheel switch shield (4).
 - b. Fasten terminal board (1) and wire lug (6) with washer (3) and nut (2).
 - c. Reconnect wiring to terminal board according to tags and solder in place; remove tags.
 - d. Install indicator cover (5); refer to paragraph 4-39.
 - e. Perform NULL METER FUNCTION CHECK according to paragraph 3-12; perform steps h (56) through (63) of BENCH ALIGNMENT, paragraph 4-58.

END OF TASK

TASK 14

Initial Set-up:

APPLICABLE CONFIGURATION:

Aircraft Weighing Kit, Type A/S 37M-1

TOOLS/TEST AND SUPPORT EQUIPMENT:

Tool Kit: 35H Calibration Set
NSN 6695-01-081-0705

MATERIALS:

Resin Core Solder, QQS-571-SN60-
W-RA-P2, dia. 0.031

PARTS :

Rotary switch S101 as required.

PERSONNEL REQUIRED:

35H Calibration and Repair Specialist

REFERENCES:

4-39. TASK 8 INDICATOR COVER REMOVAL/
INSTALL .
4-58. TASK 27 BENCH ALIGNMENT.

EQUIPMENT CONDITION:

Power disconnected.
Indicator cover removed from housing.

Performance:

1. REMOVE ROTARY SWITCH.
 - a. Set arrow of selector knob (1) to middle position and loosen two setscrews (2) with Allen wrench. Pull knob off shaft (3).
 - b. Remove retaining nut (4) and lockwasher (5) from shaft (3). Remove switch assembly (6) from back of indicator cover (7).
 - c. Support switch assembly (6) on bench vise or electronic positioner and tag wires. Clip wires as close to connections as possible or unsolder.

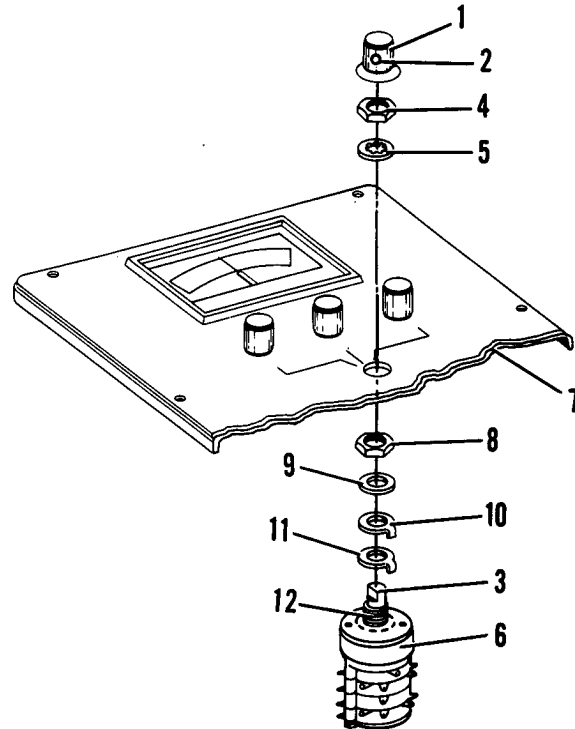

GO TO NEXT PAGE

4-45. ROTARY SWITCH S101 REMOVAL/REPLACEMENT. (CONT)

4-45

2. REPLACE ROTARY SWITCH.
 - a. Switch setting stops must be set on new switch before installation. Remove nut (4), lock washer (5), nut (8), and keeper (9). Rotate shaft (3) fully counterclockwise, being careful not to damage shaft. Remove upper stop washer (10); position lower stop washer (11) in stop slot 1. Position upper stop washer (10) in stop slot 3. Replace keeper (9) and nut (8), and test switch settings by rotating shaft (3) through left, center, and right positions. Reset switch (6) to center position.
 - b. Strip wires and with replacement switch (6) supported in electronic positioner solder wires to terminals. Remove tags.
 - c. Insert shaft in indicator cover (7) making sure indexing tab (12) is in indent, secure with lock washer (5) and nut (4).
 - d. Slide selector knob (1) onto shaft (3) with index arrow centered, 2nd position from left stop, and secure with two setscrews (2).
 - e. Perform BENCH ALIGNMENT according to paragraph 4-58.

END OF TASK

TASK 15

Initial Set-up:

APPLICABLE CONFIGURATION:

Aircraft Weighing Kit, Type A/S 37M-1

TOOLS/TEST AND SUPPORT EQUIPMENT:

Tool Kit: 35H Calibration Set
NSN 6695-01-081-0705

MATERIALS:

Resin Core Solder, QQS-571-SN60-
W-RA-P2, dia. 0.031

PARTS :

Zero set controls (R101, R102, R103)
as required.

PERSONNEL REQUIRED:

35H Calibration and Repair Specialist

REFERENCES:

4-39. TASK 8 INDICATOR COVER REMOVAL/
INSTALL .
4-58. TASK 27 BENCH ALIGNMENT.

EQUIPMENT CONDITION:

Power disconnected.
Indicator cover removed from housing.

Performance:

1. REMOVE ZERO SET CONTROL.
 - a. This procedure may be used to change any or all of the three zero set controls. Tag wires and unsolder. Note location of each color-coded zero set knob.
 - b. Loosen two setscrews (1) on knob (2) with allen wrench. Slip knob off shaft (3), remove retaining nut (4) and lockwasher (5) from shaft and remove zero set control (6) from back of indicator cover (7).

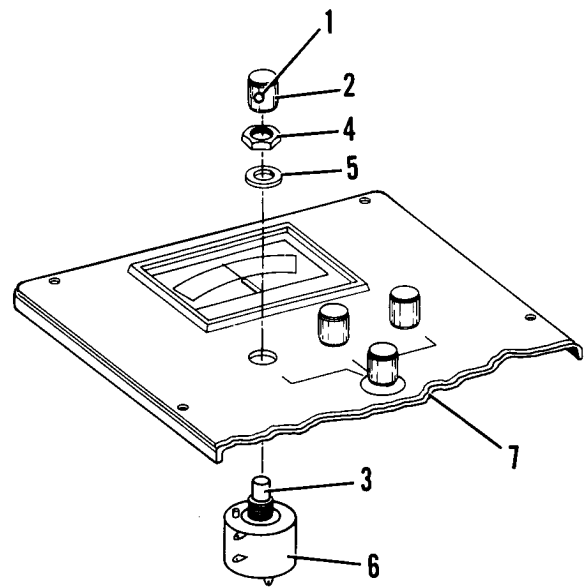

GO TO NEXT PAGE

4-46. ZERO SET CONTROL REMOVAL/REPLACEMENT. (Cont)

4-46

2. REPLACE ZERO SET CONTROL.
 - a. Slip zero set control (6) into place from back of indicator cover (7), align stud in hole in cover plate, and secure with lockwasher (5) and nut (4). Push color-coded knob (2) onto shaft (3) and secure with setscrews (1).
 - b. Solder wires to terminals, remove tags.
3. Perform BENCH ALIGNMENT according to paragraph 4-58.

END OF TASK

4-47. THUMBWHEEL SWITCH REMOVAL/REPLACEMENT.

4-47

TASK 16

Initial Set-up:

APPLICABLE CONFIGURATION:

Aircraft Weighing Kit, Type A/S 37M-1

TOOLS/TEST AND SUPPORT EQUIPMENT:

Tool Kit: 35H Calibration Set
NSN **6695-01-081-0705**

MATERIALS:

Resin Core Solder, QQS-571-SN60-
W-RA-P2, dia. 0.031

PARTS :

THUMBWHEEL switch as required.

PERSONNEL REQUIRED:

35H Calibration and Repair Specialist

REFERENCES:

4-39. TASK 8 INDICATOR COVER REMOVAL/
INSTALL .
4-58. TASK 27 BENCH ALIGNMENT.

EQUIPMENT CONDITION:

Power disconnected.
Indicator cover removed from housing.

Performance:

1. REMOVE THUMBWHEEL SWITCH.
 - a. With indicator cover removed from housing, place face down on cloth, remove nut (1) and lockwasher (2), from stud (3). Remove terminal board TB101 (4) from switch shield (5) and carefully move aside.
 - b. Remove nut (6) and lockwasher (7) from stud (8), and gently work switch shield (5) free from indicator cover (9).
 - c. Tag wires on switch and unsolder. Note: Red, Black, and Green wire terminals are color-coded on the switch.

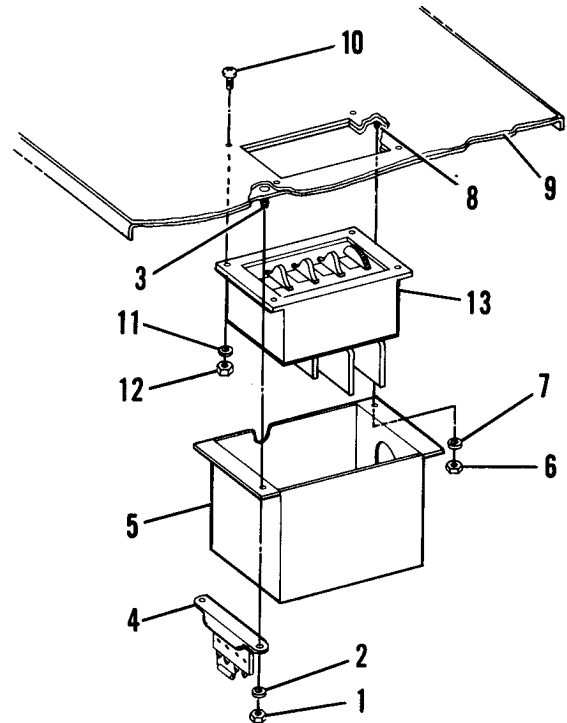

GO TO NEXT PAGE

4-47. THUMBWHEEL SWITCH, REMOVAL/REPLACEMENT. (Cont)

4-47

- d. Remove four retaining screws (10), washers (11), nuts (12) from front of indicator cover. Remove switch (13) from back of cover.
2. REPLACE THUMBWHEEL SWITCH.
 - a. Insert switch (13) from back of indicator cover and secure with four screws (10), washers (11), and nuts (12).
 - b. Solder wires to terminals on switch, remove tags.
 - c. Slide switch shield (5) into place on studs (3), (8) and secure with lockwasher (7) and nut (6).
 - d. Reposition terminal board (4) on stud (3) and secure with lock washer (2) and nut (1).
 3. Perform BENCH ALIGNMENT according to paragraph 4-58.

CAUTION

Use a cloth dampened with isopropyl alcohol for cleaning. Isopropyl alcohol is the only acceptable cleaning solvent that may be used on the POUNDS thumbwheel switch, S104. Fumes from other solvents may damage switch.

END OF TASK

TASK 17

Initial Set-up:

APPLICABLE CONFIGURATION:

Aircraft Weighing Kit, Type A/S 37M-1

TOOLS/TEST AND SUPPORT EQUIPMENT:

Tool Kit: 35H Calibration Set
NSN 6695-01-081-0705

PERSONNEL REQUIRED:

35H Calibration and Repair Specialist

REFERENCES:

4-12. TASK 7 AIRCRAFT WEIGHING KIT PERFORMANCE CHECK.
4-39. TASK 8 INDICATOR COVER REMOVAL/INSTALL.

EQUIPMENT CONDITION:

Power disconnected.
Indicator cover removed from housing.

Performance:

NOTE

Indicator housing must be removed from case assembly to perform TASKS 19, 20, and 21.

1. REMOVE INDICATOR HOUSING FROM CASE ASSEMBLY.
 - a. Remove one orange, two red, two white spade lugs from TB-1 (1) and TB-2 (2) to allow RFI baffle shield (3) to move forward.
 - b. Loosen shield (3) from housing (4) by removing two nuts (5) and washers (6) from two screws (7) nearest center of housing. Loosen remaining nuts (8) and slide RFI baffle shield to the left or center until clear of the two screws (9), gently pull away from

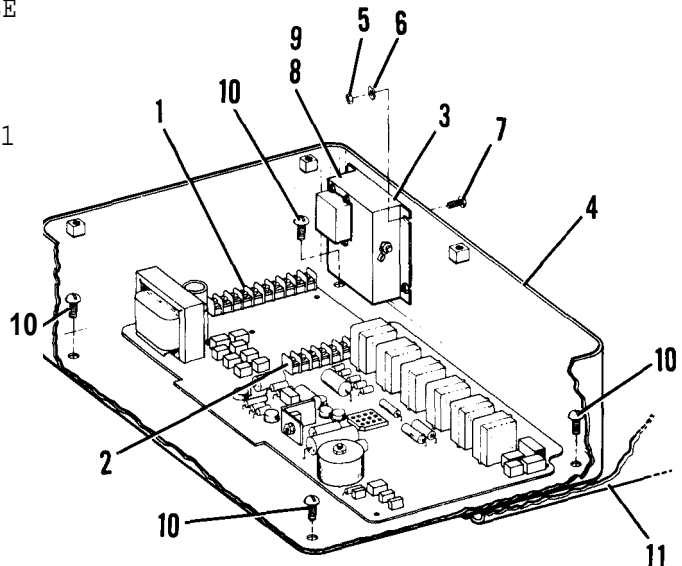

GO TO NEXT PAGE

4-48. INDICATOR HOUSING REMOVAL/ INSTALL. (Cent)

4-48

housing about 1/4 inch or until a screwdriver can be inserted between the shield and the housing, for access to mounting screw (10).

- c. Remove four mounting screws (10) that secure indicator housing to shock mounts.
 - d. Remove indicator housing (4), then three load cell cables, and reels from case assembly (11).
2. INSTALL INDICATOR HOUSING.
- a. Place indicator housing (4) load cell cables and reels into case assembly (11). Position over mounting holes on shock mounts. Secure with four screws (10).
 - b. Push RFI baffle shield (3) back onto housing (4), realign baffle slots with two screws (9) and tighten nuts (8). Install two washers (6), two nuts (5), on two screws (7), and tighten to secure baffle shield to housing. Handle wires carefully; do not pinch.
 - c. Reattach color coded wires to TB-1 (1) and TB-2 (2).
 - d. Perform AIRCRAFT WEIGHING KIT PERFORMANCE CHECK according to paragraph 4-12.

END OF TASK

4-49. RFI BAFFLE SHIELD AND EMI FILTER REMOVAL/REPLACEMENT.

4-49

TASK 18

Initial Set-up:

APPLICABLE CONFIGURATION:

Aircraft Weighing Kit, Type A/S 37M-1

TOOLS/TEST AND SUPPORT EQUIPMENT:

Tool Kit: 35H Calibration Set
 NSN 6695-01-081-0705
 Heyco #29 Pliers

MATERIALS:

Resin Core Solder, QQS-571-SN60-
 W-RA-P2, dia. 0.031
 Heat Shrink Tubing

PARTS :

EMI Filter, as required.

PERSONNEL REQUIRED:

35H Calibration and Repair Specialist

REFERENCES:

- 1-8. DIFFERENCES BETWEEN MODELS.
- 4-39. TASK 8 INDICATOR COVER
 REMOVAL/INSTALL .
- 4-48. TASK 17 INDICATOR HOUSING
 REMOVAL/INSTALL.
- 4-58. TASK 27 BENCH ALIGNMENT.

EQUIPMENT CONDITION:

Power disconnected.
 Indicator cover removed from housing.
 Indicator housing removed from case
 assembly.

Performance:

1. REMOVE RFI BAFFLE SHIELD/EMI
 FILTER.
 - a. Tag color-coded wires noting
 to which load cell each
 connects; remove wires from
 TB-1 (1) and TB-2 (2).
 - b. Remove two nuts (3), two
 washers (4), and two screws
 (5) from center side of baffle
 shield (6). Loosen two screws
 (7), and nuts (8) on right
 side of baffle shield.
 - c. Release cable strain relief
 bushings (9) with Heyco #29
 pliers and remove from cables
 (10). Push cables into

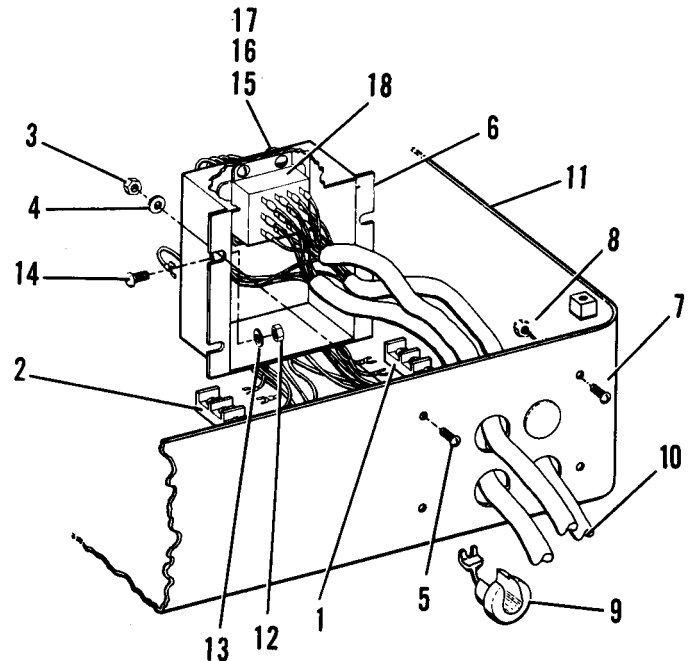

GO TO NEXT PAGE

4-49. RFI BAFFLE SHIELD AND EMI FILTER REMOVAL/REPLACEMENT. (Cont)

4-49

- housing (11) while pulling baffle shield into position for access to the interior. Hold in position with bench vise or electronic positioner.
- d. Loosen nut (12), washer (13), and screw (14); disconnect ground wires.
 - e. Remove four nuts (15), four washers (16), and four screws (17), and remove filter (18) from baffle shield.
 - f. Note filter terminal designations and tag wires on both sides of filter, clip wires close to terminal connectors.
2. INSTALL EMI FILTER/REPLACE RFI BAFFLE SHIELD
- a. Strip wires, and on cable wires slip heat shrink tubing onto wires and push up on wires out of the way. Insert cable through hole in housing.
 - b. Holding replacement filter (18) in bench vise or electronic positioner, solder wires to proper terminals. Slide heat shrink tubing over soldered joints on load cell cables and shrink in place. Remove tags.
 - c. Remove filter (18) from holding fixture and feed wires into the baffle shield (6). Secure with four screws (17), washers (16), and nuts (15).
 - d. Reattach ground wires under screw (13) and tighten screw (14), washer (13), and nut (12).
 - e. Carefully form cables and pull baffle shield (6) into position on housing (11). Align slots on flange with two screws (7) and tighten nuts (8). Install two screws (5), two washers (4), two nuts (3); secure baffle shield to housing.
 - f. Reconnect wires to TB-1 (1) and TB-2 (2) noting color codes printed on circuit card.
 - g. With Heyco #29 pliers attach cable strain relief bushings (9) to three load cell cables (10). Push carefully into housing taking care not to disturb cable positions.
 - h. Perform BENCH ALIGNMENT according to paragraph 4-58.

END OF TASK

4-50. FUSEHOLDER REMOVAL/REPLACEMENT.

4-50

TASK 19

Initial Set-up:

APPLICABLE CONFIGURATION:

Aircraft Weighing Kit, Type A/S 37M-1

TOOLS/TEST AND SUPPORT EQUIPMENT:

Tool Kit: 35H Calibration Set
NSN 6695-01-081-0705

MATERIALS:

Resin Core Solder, QQS-571-SN60-W-RA-P2, dia. 0.031

PARTS :

Fuseholder, as required.

PERSONNEL REQUIRED:

35H Calibration and Repair Specialist

REFERENCES:

- 3-12. TASK 1 NULL METER FUNCTION CHECK.
- 4-12. TASK 7 AIRCRAFT WEIGHING KIT PERFORMANCE CHECK.
- 4-39. TASK 8 INDICATOR COVER REMOVAL/INSTALL.
- 4-48. TASK 17 INDICATOR HOUSING REMOVAL/INSTALL .

EQUIPMENT CONDITION:

Power disconnected.
Indicator cover removed from housing.
Indicator housing removed from case assembly.

Performance:

1. REMOVE FUSEHOLDER
 - a. Remove fuses (1) and (2) from fuseholder (3).
 - b. Remove two nuts (4), two washers (5), and screws (6) and lift fuseholder (3) clear of indicator housing (7).
 - c. Tag wires and unsolder.
2. REPLACE FUSEHOLDER.
 - a. Resolder wires to new fuseholder terminals.

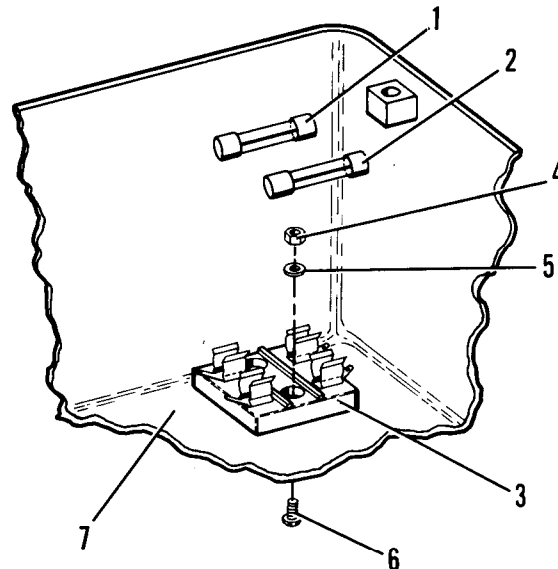

GO TO NEXT PAGE

4-50. FUSEHOLDER REMOVAL/REPLACEMENT. (Cont)

4-50

- b. Install new fuseholder (3), aligning on mounting holes in indicator housing (7) and securing with two screws (6), washers (5), and nuts (4).
- c. Insert fuses (1) and (2).
- d. Install indicator housing in case assembly; refer to paragraph 4-48 and install indicator cover; refer to paragraph 4-39.
- e. Perform function check; refer to paragraph 3-12. Perform battery check both modes ac-dc.
- f. Perform AIRCRAFT WEIGHING KIT PERFORMANCE CHECK according to paragraph 4-12.

END OF TASK

4-51. CIRCUIT CARD ASSEMBLY, AMPLIFIER, OSCILLATOR REMOVAL/REPLACEMENT.

4-51

TASK 20

Initial Set-up:

APPLICABLE CONFIGURATION:

Aircraft Weighing Kit, Type A/S 37M-1

TOOLS/TEST AND SUPPORT EQUIPMENT:

Tool Kit: 35H Calibration Set
NSN 6695-01-081-0705

PARTS :

Circuit card assembly as required.

PERSONNEL REQUIRED:

35H Calibration and Repair Specialist

REFERENCES:

4-39. TASK 8 INDICATOR COVER REMOVAL/
INSTALL.
4-58. TASK 27 BENCH ALIGNMENT.

EQUIPMENT CONDITION:

Power disconnected.
Indicator cover removed from housing.

Performance:

1. REMOVE CIRCUIT CARD ASSEMBLY.
 - a. Unplug P1 (1) and set aside.
 - b. Tag color-coded wires noting to which load cell each connects; remove wires from TB-1 (2) and TB-2 (3).
 - c. Remove seven screws (4) from standoff studs (5).
 - d. Pull circuit card (6) out of connector P101 (7). Push as far back under RFI baffle shield as possible, raise front over connector P101 (7), and lift forward and out.
2. REPLACE CIRCUIT CARD ASSEMBLY.
 - a. Push circuit card (6) into connector P101 (7) using reverse procedure described in 1.d.

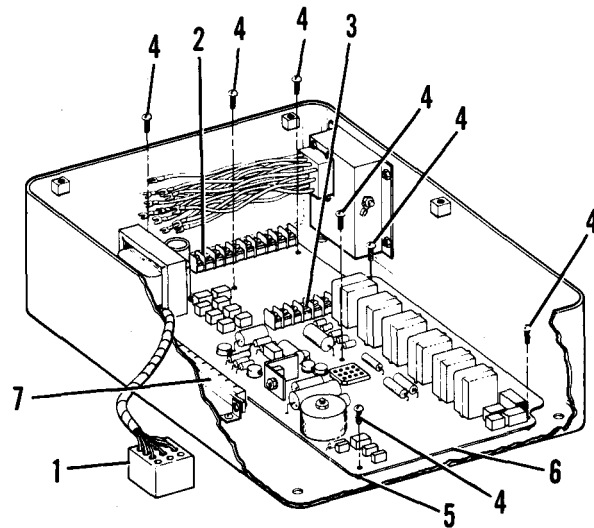

GO TO NEXT PAGE

4-51. CIRCUIT CARD ASSEMBLY, AMPLIFIER, OSCILLATOR REMOVAL/REPLACEMENT. {Cont}

4-51

- b. Attach to standoff studs (5) with seven screws (4).
- c. Attach wires to TB-1 (2) and TB-2 (3). Remove tags noting color codes printed on circuit card assembly.
- d. Plug in P1 (1).
- e. Perform BENCH ALIGNMENT according to paragraph 4-58.

END OF TASK

TASK 21

Initial Set-up:

APPLICABLE CONFIGURATION:

Aircraft Weighing Kit, Type A/S 37M-1

TOOLS/TEST AND SUPPORT EQUIPMENT:

Tool Kit: 35H Calibration Set
NSN 6695-01-081-0705

MATERIALS:

Resin Core Solder, QQS-571-SN60-
W-RA-P2, dia. 0.031

PARTS :

Transformer T101, as required.

PERSONNEL REQUIRED:

35H Calibration and Repair Specialist

REFERENCES:

- 4-39. TASK 8 INDICATOR COVER REMOVAL/
INSTALL .
- 4-48. TASK 17 INDICATOR HOUSING
REMOVAL/REPLACEMENT .
- 4-51. TASK 20 CIRCUIT CARD ASSEMBLY,
AMPLIFIER, OSCILLATOR REMOVAL/
REPLACEMENT.
- 4-53. TASK 22 CONNECTOR P101 REMOVAL/
REPLACEMENT.
- 4-58.. TASK 27 BENCH ALIGNMENT.

EQUIPMENT CONDITION:

Power disconnected.
Indicator cover removed from housing.
Circuit card assembly removed.
Connector P101 removed from brackets.

Performance:

1. REMOVE TRANSFORMER T101.
 - a. Remove two nuts (1), washers (2), and screws (3).
 - b. Remove transformer (4) from side of housing.
 - c. Tag wires from transformer to connector P101 and unsolder.
 - d. Unsolder two blue wires from P101 edge connector (5) #17 and two white wires to edge connector (5) S.

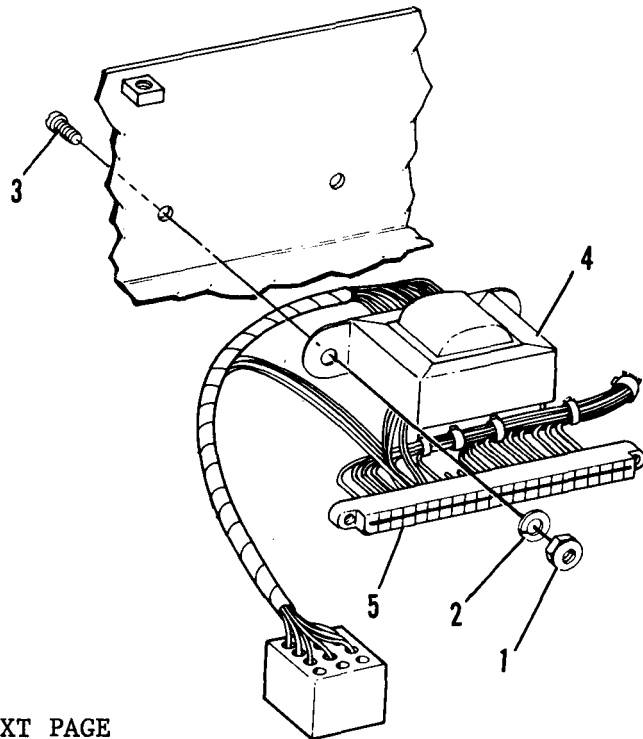

GO TO NEXT PAGE

4-52. TRANSFORMER T101 REMOVAL/REPLACEMENT. (Cont)

4-52

2. REPLACE TRANSFORMER T101.
 - a. Solder wires from transformer to connector, two blue wires to P101 edge connector (5) #17 and two white wires to edge connectors (5) S, and reinstall connector; refer to paragraph 4-55 and FO-1, View AA.
 - b. Align transformer with holes in side of housing, insert two screws (3) and secure with washers (2) and nuts (1).
 - c. Install circuit card assembly; refer to paragraph 4-51.
 - d. Plug wiring harness P1 into J1 on circuit card assembly.
3. Install indicator housing in case assembly (refer to paragraph 4-48) and install indicator cover (refer to paragraph 4-39).
4. Perform BENCH ALIGNMENT according to paragraph 4-58.

END OF TASK

4-53. CONNECTOR P101 REMOVAL/REPLACEMENT.

TASK 22

Initial Set-up:

APPLICABLE CONFIGURATION:

Aircraft Weighing Kit, Type A/S 37M-1

TOOLS/TEST AND SUPPORT EQUIPMENT:

Tool Kit: 35H Calibration Set
NSN 6695-01-081-0705

MATERIALS:

Resin Core Solder, QQs-571-SN60-W-RA-P2, dia. 0.031
Cable Tie TYB-23M, MIL-23190

PARTS :

Connector P101 as required.

PERSONNEL REQUIRED:

35H Calibration and Repair Specialist

REFERENCES:

- 4-39. TASK 8 INDICATOR COVER REMOVAL/INSTALL .
- 4-51. TASK 20 CIRCUIT CARD ASSEMBLY, AMPLIFIER, OSCILLATOR REMOVAL/REPLACEMENT.
- 4-52. TASK 21 TRANSFORMER T101 REMOVAL/REPLACEMENT .
- 4-58. TASK 27 BENCH ALIGNMENT.

EQUIPMENT CONDITION:

Power disconnected.
Indicator cover removed from housing.
Circuit card assembly removed.

Performance:

1. REMOVE CONNECTOR P101.
 - a. Cut cable tie (1) securing wiring harness (2) to pad mount (3).
 - b. Remove transformer T101 (4).
 - c. Remove two nuts (5), lock-washers (6), and screws (7), and pull connector (8) off bracket (9) for access to terminals.
 - d. Tag wires from wiring harness and transformer and remove by snipping or unsoldering while holding connector in electronic positioner.

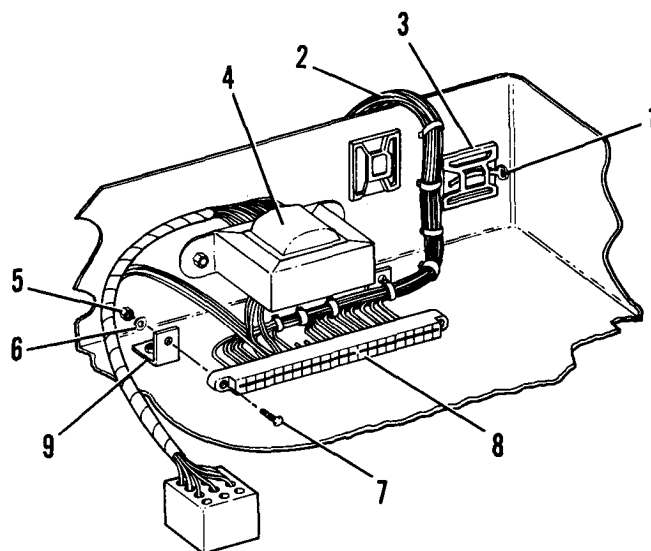

GO TO NEXT PAGE

4-53 CONNECTOR P101 REMOVAL/REPLACEMENT. (Cont)

4-53

2. REPLACE NEW CONNECTOR.
 - a. Strip wires in harness and from transformer.
 - b. With connector in holding fixture, resolder all wires. Remove tags.
 - c. Push wiring harness back and align mounting holes on connector (8) and bracket (9). Secure with two screws (7), lock washers (6), and nuts (5).
 - d. Install transformer T101 (4); refer to paragraph 4-52.
 - e. Secure wiring harness (2) to pad (3) mount with cable tie (1).
 - f. Perform BENCH ALIGNMENT according to paragraph 4-58.

END OF TASK

TASK 23

Initial Set-up:

APPLICABLE CONFIGURATION:

Aircraft Weighing Kit, Type A/S 37M-1

TOOLS/TEST AND SUPPORT EQUIPMENT:

Tool Kit: 35H Calibration Set
NSN 6695-01-081-0705

MATERIALS:

Resin Core Solder, QQS-571-SN60-W-RA-P2, dia. 0.031

PARTS :

Filters FL3, FL4, and FL5 and RFI baffle shield as required (refer to paragraph 1-8).

PERSONNEL REQUIRED:

35H Calibration and Repair Specialist

REFERENCES:

1-8. DIFFERENCE BETWEEN MODELS.
3-12. TASK 1 NULL METER FUNCTION CHECK.
4-39. TASK 8 INDICATOR COVER REMOVAL/INSTALL .
4-51. TASK 20 CIRCUIT CARD ASSEMBLY, AMPLIFIER, OSCILLATOR REMOVAL/REPLACEMENT.

EQUIPMENT CONDITION:

Power disconnected.
Indicator cover removed from housing.
Circuit card assembly removed from housing.

Performance:

1. REMOVE FILTERS FL3, FL4, and FL5.
 - a. Remove four nuts (1), washers (2), and screws (3) that fasten RFI baffle shield (4) to housing (5).
 - b. Move RFI baffle shield (4) away from housing (5) for access to interior.
 - c. Tag wires and unsolder from filters FL3 (6), FL4 (7), and FL5 (8) as required on both sides of filter.
 - d. Unscrew nut (9), remove lock washer (10), and remove filter from shield.

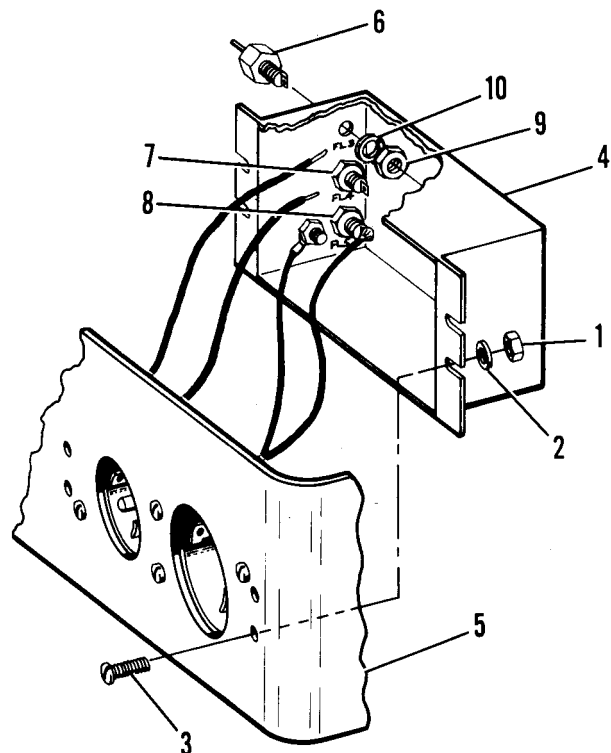

GO TO NEXT PAGE

4-54 POWER RECEPTACLE RFI BAFFLE SHIELD/FILTER REMOVAL/REPLACEMENT. (Cont)

4-54

NOTE

When replacing filters in kits with a serial number between 5740A and 5894A, replace all filters and the RFI shield as a matched set.

- 2* REPLACE FILTERS FL3, FL4, AND FL5 AS REQUIRED.
- a. Insert new filters 6, 7, or 8 as required in proper hole in RFI baffle shield (4), secure with lockwasher (10) and nut (9).
 - b. Resolder wires, both sides of filter, remove tags.
 - c. Reposition RFI baffle shield (4) on housing (5) and secure with four screws (3), washers (2), and nuts (1).
 - d. Perform NULL METER FUNCTION CHECK according to paragraph 3-12.

END OF TASK

4-55. CIRCUIT CARD ASSEMBLY COMPONENTS REMOVAL/REPLACEMENT.

TASK 24

Initial Set-up:

APPLICABLE CONFIGURATION:

Aircraft Weighing Kit, Type A/S 37M-1

PERSONNEL REQUIRED:

35H Calibration and Repair Specialist

TOOLS/TEST AND SUPPORT EQUIPMENT:

Tool Kit: 35H Calibration Set
NSN 6695-01-081-0705

REFERENCES:

- 4-39. TASK 8 INDICATOR COVER REMOVAL/INSTALL .
- 4-51. TASK 20 CIRCUIT CARD ASSEMBLY, AMPLIFIER, OSCILLATOR REMOVAL/REPLACEMENT.
- 4-58. TASK 27 BENCH ALIGNMENT.

MATERIALS:

Resin Core Solder, QQS-571-SN60-W-RA-P2, dia. 0.031

EQUIPMENT CONDITION:

Power disconnected.
Indicator cover removed from housing.
Circuit card assembly removed from housing.

PARTS :

As needed.

Performance:

REMOVE AND REPLACE CIRCUIT CARD ASSEMBLY COMPONENTS.

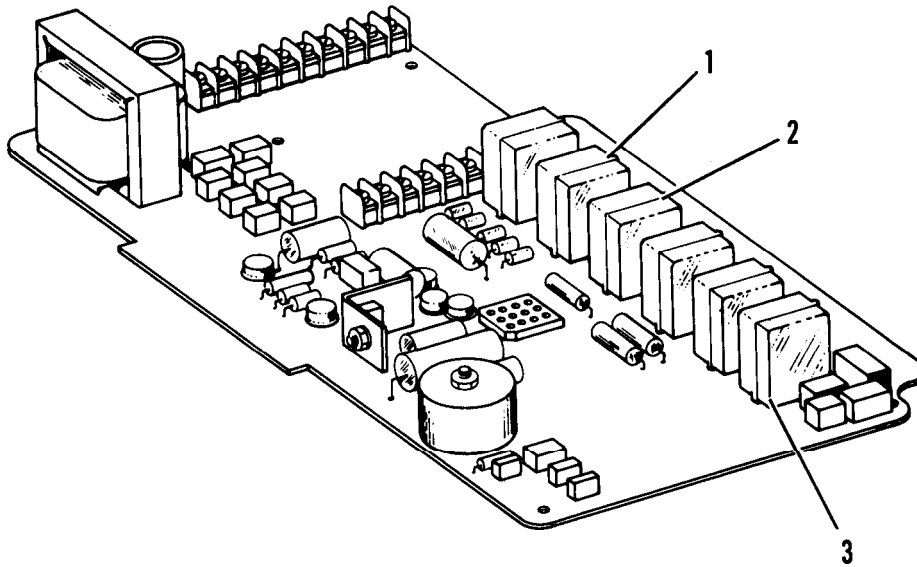

GO TO NEXT PAGE

4-55. CIRCUIT CARD ASSEMBLY COMPONENTS REMOVAL/REPLACEMENT. (Cont)

4-55

- a. Relays K1, K2, K3, K4, K5, and K6 (1) may be removed by releasing retainer spring (2) and unplugging relay from receptacle (3). Replace by plugging replacement relay into receptacle and securing with retainer.
- b. All other components may be removed and replaced using standard resoldering and soldering techniques.
- c. Bench align after replacing-soldering, or adjusting any component according to paragraph 4-58.

END OF TASK

4-56. AC AND DC POWER CABLE REPLACEMENT.

4-56

TASK 25

Initial Set-up:

APPLICABLE CONFIGURATION:

Aircraft Weighing Kit, Type A/S 37M-1

PERSONNEL REQUIRED:

68F Aircraft Electrician

TOOLS/TEST AND SUPPORT EQUIPMENT:

Multimeter AN/PSM-45 or equivalent.
 Tool Kit: Electrical Repairer:
 Army Aircraft, NSN 5180-00-323-4915

REFERENCES:

3-12. TASK 1 NULL METER FUNCTION CHECK.
 APPENDIX C, Figure C-5.

PARTS :

Cables, as required.

EQUIPMENT CONDITION:

Power disconnected.
 Cables disconnected from indicator.

Performance:INSPECT AC AND DC POWER CABLES AND BATTERY EXTENSION CABLE.

- a. Visually inspect 3-wire ac power cable, 2-wire dc power cable, 2-wire dc power cable extension, and dc battery extension cable for signs of physical damage.
- b. If damage to cables is evident, replace each cable, as required, with a new cable.
- c. Connect cables, one conductor at a time, to multimeter and check for continuity and shorts. Flex cables while testing.
- d. Perform NULL METER FUNCTION CHECK according to paragraph 3-12.

GO TO NEXT PAGE

4-56. AC AND DC POWER CABLE REPLACEMENT. (Cont)

4-56

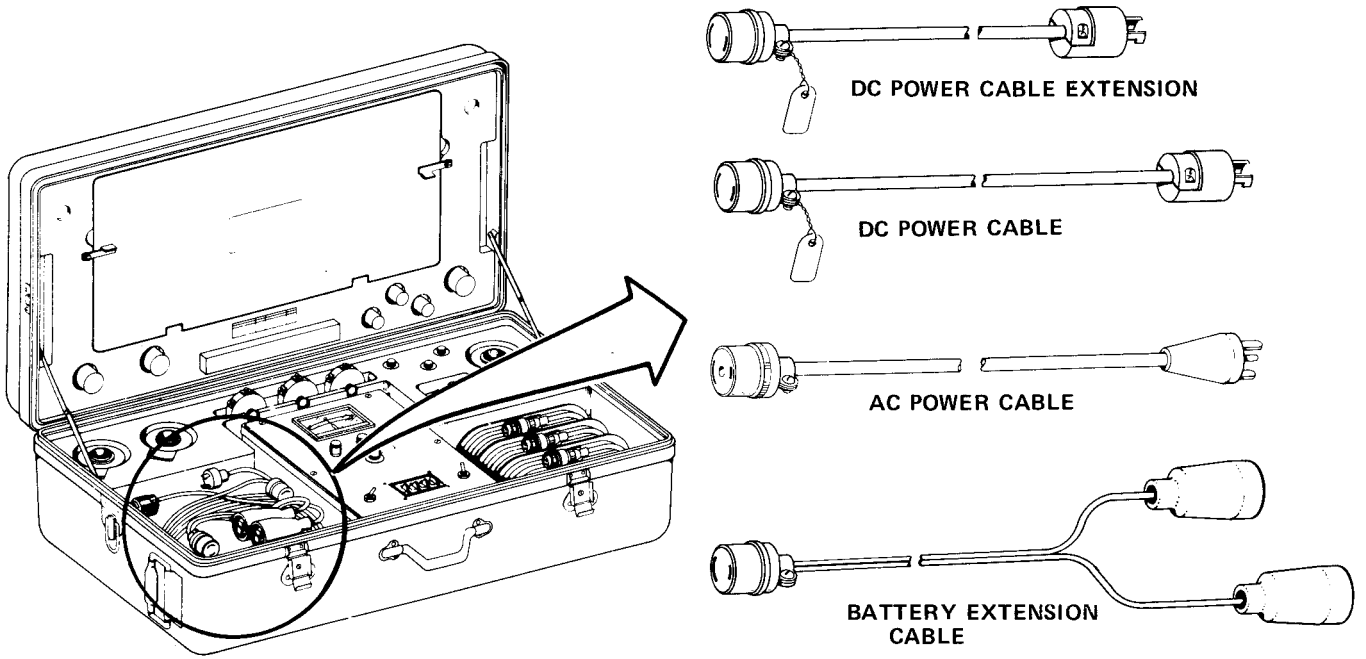

END OF TASK

TASK 26

Initial Set-up:

APPLICABLE CONFIGURATION:

Aircraft Weighing Kit, Type A/S 37M-1

TOOLS/TEST AND SUPPORT EQUIPMENT:

Tool Kit: 35H Calibration Set
 NSN 6695-01-081-0705
 Heyco #29 Pliers

MATERIALS:

Resin Core Solder, QQS-571-SN60-
 W-RA-P2, dia. 0.031
 Heat Shrink Tubing
 Red, White, and Blue Pressure
 Sensitive Tape

Load cell cable, as required.

PERSONNEL REQUIRED:

35H Calibration and Repair Specialist

REFERENCES:

4-39. TASK 8 INDICATOR COVER REMOVAL/
 INSTALL.
 4-48. TASK 17 INDICATOR HOUSING
 REMOVAL/INSTALL .
 4-58. TASK 27 BENCH ALIGNMENT.

EQUIPMENT CONDITION:

Power disconnected.
 Indicator cover removed from housing.
 Indicator housing removed from case
 assembly.

Performance:

1. REMOVE LOAD CELL CABLE.
 - a. Tag color-coded wires noting to which load cell each connects; remove wire from TB-1 (1) and TB-2 (2).
 - b. Remove two nuts (3), two washers (4), and two screws (5) from center side of baffle shield (6). Loosen two screws (7), and nuts (8) on right side of baffle shield.
 - c. Release cable strain relief bushings (9) with Heyco #29 pliers and remove from cables (10). Push cables into

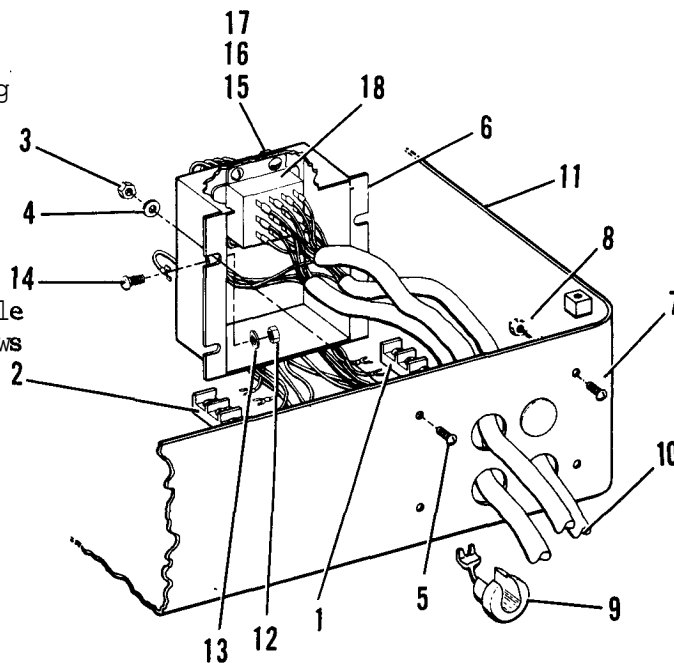

GO TO NEXT PAGE

4-57. LOAD CELL CABLE REMOVAL/REPLACEMENT. (Cont)

4-57

- housing (11) while pulling baffle shield into position for access to the interior. Hold in position with bench vise or electronic-positioner.
- d. Loosen nut (12), washer (13), and screw (14), disconnect ground wires.
 - e. Remove four nuts (15), four washers (16), and four screws (17), and remove filter (18) from baffle shield.
 - f. Tag wires on load cell cable side of filter, snip wires close to terminal connectors.
2. INSTALL NEW LOAD CELL CABLE.
- a. Insert cable through hole in housing, slip heat shrink tubing onto wires, and slide away from point to be soldered.
 - b. Holding filter (18) in bench vise or electronic positioner, solder wires to proper terminals. Slide heat shrink tubing over soldered joints on load cell cables and shrink in place. Remove tags.
 - c. Remove filter (18) from holding fixture and feed wires into the baffle shield (6). Secure with four screws (17), washers (16), and nuts (15).
 - d. Reattach ground wires under screw (14) and tighten screw (14), washer (13), and nut (12).
 - e. Carefully form cables and pull baffle shield (6) into position on housing (11). Align slots on flange with two screws (7) and tighten nuts (8). Install two screws (5), two washers (4), and two nuts (3); secure baffle shield to housing.
 - f. With Heyco #29 pliers attach cable strain relief bushings (9) to three load cell cables (10). Carefully push into housing holes taking care not to disturb cable positions.
 - g. Reconnect wires to TB-1 (1) and TB-2 (2) noting color codes printed on circuit card.
 - h. Attach color coded tape to new connector.
 - i. Perform BENCH ALIGNMENT according to paragraph 4-58.

END OF TASK

TASK 27

Initial Set-up:

APPLICABLE CONFIGURATION:

Aircraft Weighing Kit, Type A/S 37M-1

TOOLS/TEST AND SUPPORT EQUIPMENT:

- Tool Kit: 35H Calibration Set
NSN 6695-01-081-0705
- Load cell simulator Revere Model R941 or equivalent
- Multimeter: AN/PSM-45 or equivalent
- Oscilloscope: Triggerable, dual beam, 500 Kc minimum bandwidth
- Adjustable ac power supply 100-135 Vat, 60 Hz
- Adjustable dc power supply 22-28 Vdc
- Adaptor cable for load cell to simulator connection: Connector (number GS02-14S-5P-001) attached to four 8" color coded wires

PERSONNEL REQUIRED:

35H Calibration and Repair Specialist

REFERENCES:

4-39. TASK 8 INDICATOR COVER REMOVAL/INSTALL.

EQUIPMENT CONDITION:

Power disconnected.
Indicator cover removed from housing.

GENERAL SAFETY INSTRUCTIONS:

Use caution when operating around unguarded 115 Vac energized circuits.

Performance:

SET UP INDICATOR> POWER SOURCES, AND TEST EQUIPMENT ACCORDING TO DIAGRAM

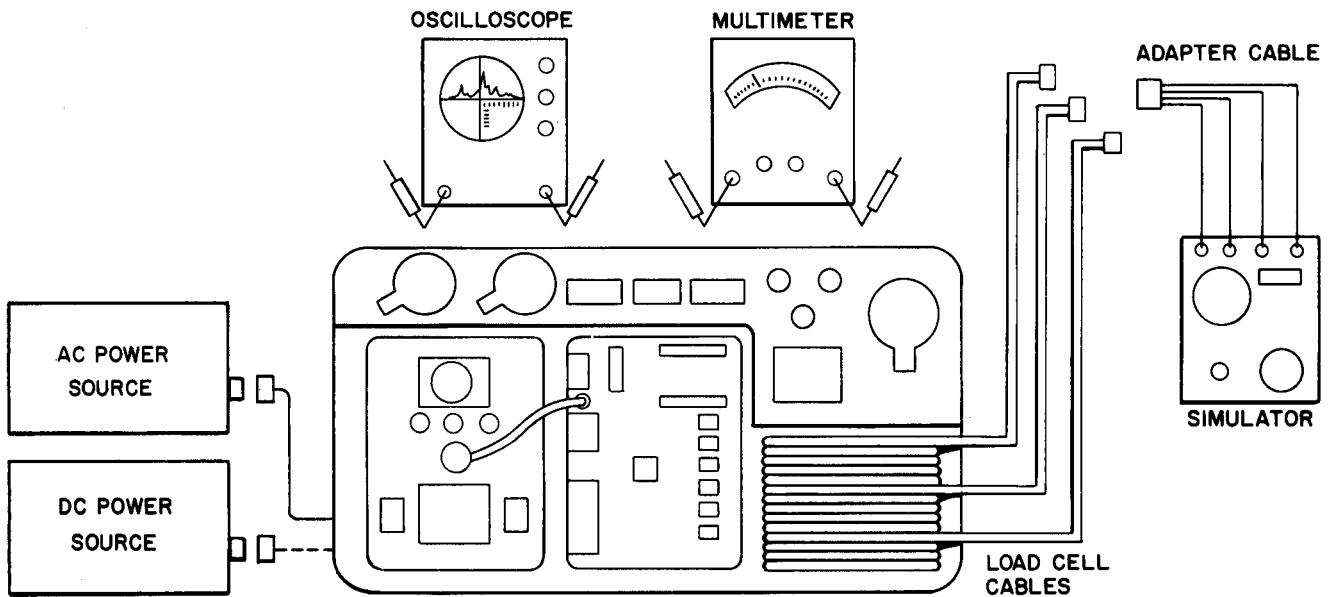

GO TO NEXT PAGE

4-58. BENCH ALIGNMENT. (Cent)

4-58

- a. Inspect entire kit for damage and missing parts (refer to paragraph 4-14).
- b. Use the battery extension cable for tests requiring external dc power source.
- c. Do not connect load-cell cable or power cables until cable checkout and electrical checks have been made.
- d. Perform checkout of ac and dc power cables.
 - (1) Visually check power cables for damaged and/or loose, or broken connectors.
 - (2) Make continuity check of cable wires using a multimeter; flex cables while testing continuity.
- e. Perform electrical checks on electronic weighing indicator using a multimeter.
 - (1) Turn POWER switch to 115 V position.
 - (2) Measure resistance across the hot and neutral terminals of 115-Vac receptacle on the left side of indicator using multimeter. Multimeter should indicate approximately 75 to 125 ohms; if not, refer to paragraph 4-16.
 - (3) Set POWER switch to 24 V position.
 - (4) Measure resistance across terminals of 24 Vdc receptacle on the left side of indicator using multimeter (positive multimeter lead goes to smaller receptacle pin, large pin is -Vdc or case ground). Multimeter should indicate 100 to 200 ohms (diode D101 forward resistance); if not, refer to paragraph 4-17.
 - (5) Set POWER switch to OFF position.
 - (6) Measure the resistance between hot and ground pin and between neutral and ground pin of the 115 Vac receptacle. Resistance should be infinite; if not, refer to paragraph 4-16.
 - (7) Measure the resistance across the pins of the 24 Vdc receptacle placing the positive multimeter probe on the positive pin. Resistance should be 2.34 megohms; if not, refer to paragraph 4-17.

GO TO NEXT PAGE

- (8) Remove indicator cover (refer to paragraph 4-39) and inspect indicator (refer to paragraph 4-15).
- (9) Arrange indicator cover so that the null meter may be observed while making following adjustments. Observe and compensate for null meter pointer shift due to indicator cover position.

**WARNING****HIGH VOLTAGE**

Use extreme caution when operating with ac power as primary voltage exists on 115-Vac receptacle (J103), filters (FL3 and FL4), fuse (F101), switch (S102), edge connector (J102), and at various points on the printed circuit card. Death can result from accidental contact.

**HIGH VOLTAGE**

Do not allow indicator cover switches to short out to case. Serious damage to indicator could result.

- f. Perform the following checks of the ac power source and the dc power source.
 - (1) Connect the ac power cable between the 115-Vac receptacle, on the left side of the indicator, and the ac power source.
 - (2) Set the POWER switch to 115 V position.
 - (3) Set the LOAD INDICATOR/BATTERY CHECK switch to the momentary BATTERY CHECK position to determine if the internal 115 Vac to 35 Vdc power supply is functioning. Null meter should indicate a reading in the green band; if not, refer to paragraph 4-18.
 - (4) Check voltages at TP-4, 5, and 6 with reference to case ground using multimeter. See Figure 4-2. Multimeter should indicate +20, 0, and +10 Vdc respectively; if not, refer to paragraph 4-19.
 - (5) Set POWER switch to OFF position.
 - (6) Disconnect the ac power cable at the ac power source.

GO TO NEXT PAGE

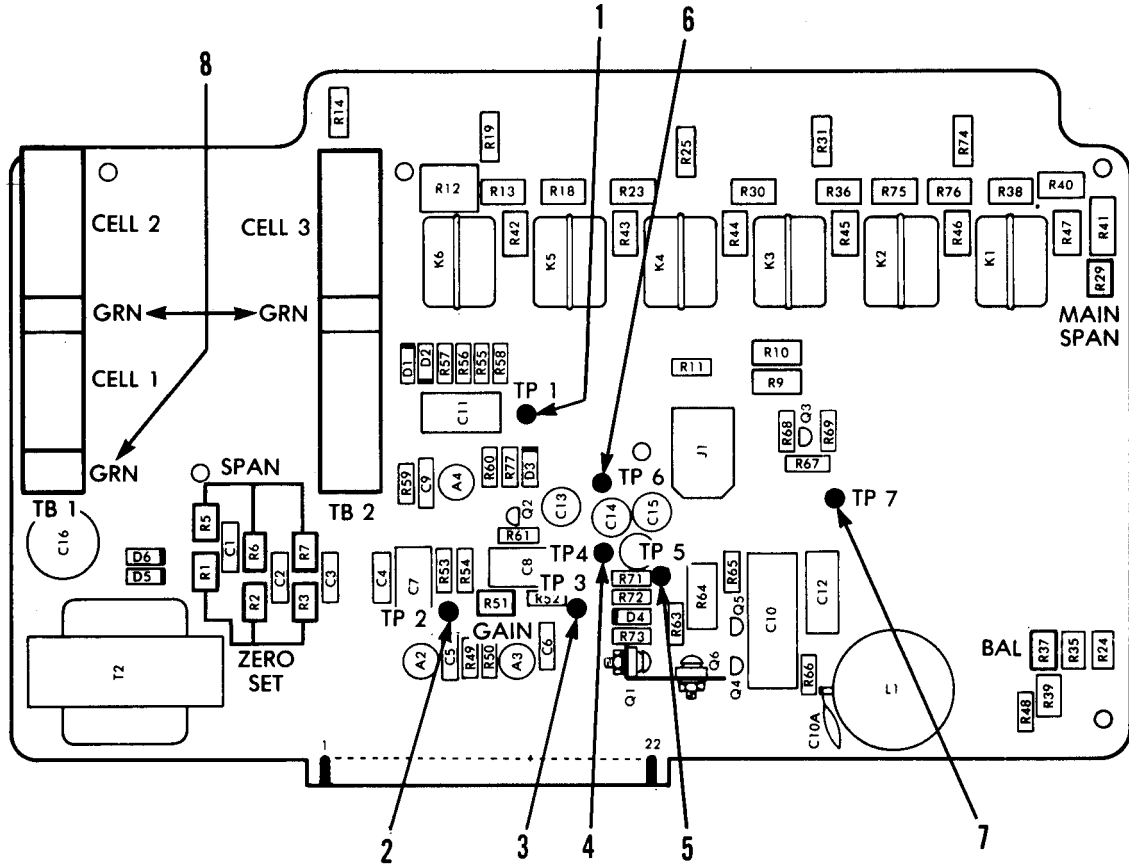

TEST POINTS

TYPICAL WAVEFORMS

1. TP-1. Operational amplifier A4 output (ac). 
2. TP-2. Operational amplifier A2 output (ac). 
3. TP-3. Operational amplifier A3 output (ac). 
4. TP-4. Transistor Q1 20 Vdc output with reference to case ground.
5. TP-5. Case ground 0 Vdc or -10 Vdc with reference to TP-6.
6. TP-6. Operational amplifier A1 output; signal common or 10 Vdc with reference to case ground.
7. TP-7. Transistor Q3 Vdc pulse output for Q2 (signal control). 
8. TP-8. Transformer T101 Vac output. 

Figure 4-2. Test Point and Adjustable Resistor Locations

GO TO NEXT PAGE

- (7) Connect the dc power cable between the 24-Vdc receptacle on the left side of the indicator, and the dc power source.
 - (8) Set POWER switch to 24-V position.
 - (9) Set the LOAD INDICATOR/BATTERY CHECK switch to the momentary BATTERY CHECK position to determine if the external dc power source polarity is correct and the voltage is within the green band. If the pointer of the null meter swings to the yellow position of the meter, reverse the dc power source connections. If voltage is outside green band, refer to paragraph 4-20.
 - (10) Check voltages at TP-4, 5, and 6 with reference to case ground using multimeter. See Figure 4-2. Multimeter should indicate +20, 0, and +10 Vdc, respectively; if not, refer to paragraph 4-19.
 - (11) Adjust dc power source from 22 to 28 Volts while checking for stable +20 Vdc at TP-4; if not stable, refer to paragraph 4-21.
- g. Perform the following checks of the load cells and cables.
- (1) Turn off external dc power source.
 - (2) Unreel the cell cables sufficiently to connect each cable to its proper load cell, observing proper color coding (red to red, yellow to yellow, and blue to blue).
 - (3) Turn on external dc power source; adjust the dc power source for an output of between 22 and 28 Volts.
 - (4) Set the POUNDS switch thumbwheels to 0-0-0-00.
 - (5) Set the CELL SELECTOR switch to CELL 1.
 - (6) Adjust R101 (CELL 1 zero set control) until null meter indicates NULL. If reading cannot be obtained, refer to paragraph 4-22.
 - (7) Set the POUNDS switch to 0-0-2-10 to perform null meter function check. Observe that the pointer of the null meter deflects to the beginning of the green band or further left. If meter does not deflect, refer to paragraph 4-23.
 - (8) Set the POUNDS switch to 0-0-0-00. With a spherical adapter placed on load cell 1, exert pressure with the palm of your hand and check that pointer of the null meter swings away from NULL into the yellow band. If meter does not deflect, refer to paragraph 4-24.

GO TO NEXT PAGE

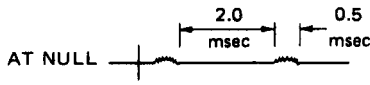
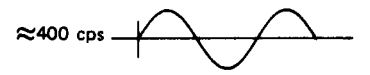
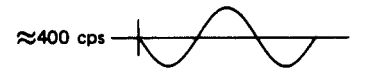
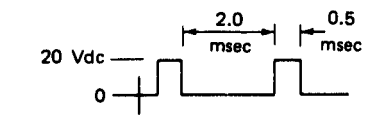
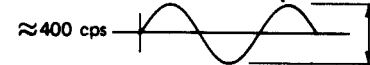
4-58. BENCH ALIGNMENT. (Cont)

4-58

- (9) Repeat steps 5-8 for load cells 2 and 3.
 - (10) Turn off external dc power source.
 - (11) Disconnect the load cells and return them to the recesses in the Aircraft Weighing Kit.
 - (12) Disconnect the dc power cable at the dc power source.
- h. Using multimeter, oscilloscope, and load cell simulator, perform bench alignment as follows:
- (1) Connect the ac power cable between the 115-Vac receptacle, on the left side of the indicator, and the ac power source.
 - (2) Connect cable connector adaptor to load cell simulator; connect load cell cable 1 (red) to cable connector adaptor.
 - (3) Set CELL SELECTOR switch to CELL 1 and adjust POUNDS switch thumbwheels to indicate zero pounds.
 - (4) Set load cell simulator for zero output.

NOTE

Kits that are known to be calibrated should be distinguished from kits that had repairs done affecting calibration. Kits that pass electrical checkout and are known to be calibrated may be checked by omitting steps 5, 32-34, 41, 44, 47, and 50 from the bench alignment procedure. At steps 32, 41, 44, 47, 50, and 55, check that the NULL reading obtained is $\pm 20\%$ of the respective POUNDS switch setting. Use the entire bench alignment procedure for repaired kits.

- (5) Preset the following adjustable resistors (see Figure 4-2) as indicated (center position is 10 to 12 turns from either end stop):
 - (a) R5, R6, and R7 (cell span potentiometers) to the full clockwise position.
 - (b) R1, R2, and R3 (cell phase potentiometers) to the approximate center position.
 - (c) R51 (operational amplifier A2 and A3 gain potentiometer) to the approximate center position.

GO TO NEXT PAGE

4-58. BENCH ALIGNMENT. (Cont)

- (d) R37 (balance-potentiometer) to the approximate center position.
 - (e) R29 (main span potentiometer) to the approximate center position.
 - (f) R14, R19, R25, and R31 (linearity potentiometer) to the approximate center position.
 - (g) R74 (zero crossover potentiometer) to the approximate center position.
- (6) Set POWER switch to 115 Vat.
 - (7) Check transformer T101 output at GRN and BLK terminals for CELL 1 at terminal board TB-1. See Figure 4-2. Multimeter should indicate approximately 3.5 Vac rms; if not, refer to paragraph 4-25.
 - (8) Adjust oscilloscope as follows:
 - (a) internal triggering
 - (b) 1 millisecond per scope screen division
 - (c) 1 Volt per scope screen division

NOTE

If scope internal triggering is not satisfactory, trigger scope externally at TP-8.

NOTE

If a scope is unavailable, the multimeter set to approximately a 3-Volt range can be substituted.

- (9) Connect oscilloscope to TP-1 on the printed circuit board and case ground (indicator cover mounting screw lug).

NOTE

Load cell simulator must be at zero output for steps 9 through 29.

- (10) Alternately adjust R1 (cell 1 phase potentiometer) and R101 (CELL 1. zero set control) for minimum amplitude waveshape, while maintaining a null meter reading. If unobtainable, refer to paragraph 4-26.

GO TO NEXT PAGE

4-58. BENCH ALIGNMENT. (Cont)

4-58

- (11) Disconnect load cell cable 1 (red) from cable connector adapter.
- (12) Connect load cell cable 2 (yellow) to cable connector adapter.
- (13) Set CELL SELECTOR to CELL 2.
- (14) Alternately adjust R2 (cell 2 phase potentiometer) then R102 (cell 2 zero set control) for minimum amplitude waveshape. See Figure 4-2. If unobtainable refer to paragraph 4-26.
- (15) Disconnect load cell cable 2 (yellow) from cable connector adapter.
- (16) Connect load cell cable 3 (blue) to cable connector adapter.
- (17) Set CELL SELECTOR to CELL 3.
- (18) Alternatively adjust R3 (cell 3 phase potentiometer) then R103 (cell 3 zero set control) for minimum amplitude waveshape. If unobtainable, refer to paragraph 4-26.
- (19) Disconnect load cell cable 3 (yellow) from cable connector adapter.
- (20) Connect load cell cable 1 (red) to cable connector adapter.
- (21) Set CELL SELECTOR to CELL 1.
- (22) With the null meter indicating NULL, set POUNDS switch thumbwheels to 0-0-1-50 (0.3% of full scale).
- (23) The null meter pointer should deflect to beginning of the green band. Adjust R51 (operational amplifier A2 and A3 gain potentiometer) if necessary.
- (24) Set POUNDS switch thumbwheels to 0-0-0-00.
- (25) Attach a jumper lead between the output terminals (red and white) of the load cell simulator (simulator must be at zero output).
- (26) Turn R101 (CELL 1 zero set control) exactly five turns from extreme counterclockwise position.
- (27) Null inter should indicate NULL; adjust R37 (balance potentiometer) if necessary. If unobtainable, refer to paragraph 4-27.

GO TO NEXT PAGE

- (28) Remove jumper lead from load cell simulator.
- (29) Readjust R101 if necessary. See Figure 4-2.
- (30) Set load cell simulator for 2.15 mV/V output.
- (31) Set the POUNDS switch thumbwheels to 4-9-9-100.
- (32) Adjust R29 (main span) until null meter indicates null.
- (33) Check R5, R6, and R7 (span potentiometers) for proper mechanical function; reset each to eight turns from extreme clockwise position.
- (34) Check R101 (with simulator set at zero output) and R29 (with simulator set at 2.15 mV/V output) and adjust if necessary. Repeat until a stable null meter indication is achieved. If unobtainable, refer to paragraph 4-28.
- (35) Adjust R101 (CELL 1 zero set potentiometer) until null meter indicates NULL, with load cell simulator at zero output and POUNDS switch thumbwheel set to indicate zero pounds.
- (36) Set the MSD thumbwheel on the POUNDS switch to the -(minus) position.
- (37) Adjust R74 (zero crossover potentiometer) until null meter indicates NULL. If unobtainable, refer to paragraph 4-29.
- (38) Alternatively turn the MSD thumbwheel on the POUNDS switch from 0 to -(minus) to check that null meter continues to indicate NULL.
- (39) Set the load cell simulator to 0.430 mV/V (20% of the full scale mV/V value).
- (40) Set the MSD thumbwheel on the POUNDS switch to indicate 10,000 pounds.
- (41) Adjust R31 (linearity potentiometer) until null meter indicates NULL. If unobtainable, refer to paragraph 4-30.
- (42) Set load cell simulator to 0.860 mV/V (40% of the full scale mV/V value).
- (43) Set the POUNDS switch thumbwheels to 2-0-0-00.
- (44) Adjust R25 (linearity potentiometer) until null meter indicates NULL. If unobtainable, refer to paragraph 4-31.

GO TO NEXT PAGE

4-58. BENCH ALIGNMENT. (Cont)

4-58

- (45) Set load cell simulator to 1.290 mV/V (60% of the full scale mV/V value).
- (46) Set the POUNDS switch thumbwheels to 3-0-0-00.
- (47) Adjust R19 (linearity potentiometer) until null meter indicates NULL . See Figure 4-2. If unobtainable, refer to paragraph 4-32.
- (48) Set load cell simulator to 1.720 mV/V (80% of the full scale mV/V value).
- (49) Set the POUNDS switch thumbwheels to 4-0-0-00.
- (50) Adjust R14 (linearity potentiometer) until null meter indicates NULL . If unobtainable, refer to paragraph 4-33.
- (51) Set load cell simulator for zero output.
- (52) Set POUNDS switch thumbwheels to indicate zero pounds.
- (53) If necessary, adjust R101 (CELL 1 zero set control) until null meter indicates NULL; repeat steps 39-53 until stable readings are obtained. If unobtainable, refer to paragraph 4-34.
- (54) Set load cell simulator to 0.430 mV/V (20% of the full scale mV/V value).
- (55) Set the POUNDS switch thumbwheels to 1-0-0-00; null meter should indicate NULL.
- (56) Set ac power source from 100 to 130 Vac in three or more steps while observing null meter for any change in null indication (zero and span change). Any change should not require that the POUNDS switch reading be changed by more than 50 pounds to obtain NULL. If unobtainable, refer to paragraph 4-35.
- (57) Turn POWER switch to OFF position.
- (58) Disconnect ac power cable at ac power source.
- (59) Connect dc power cable to dc power source.
- (60) Turn POWER switch to 24V position.

GO TO NEXT PAGE

4-83

- (61) Set dc power source to 22 Vdc.
- (62) Set the LOAD INDICATOR/BATTERY CHECK switch to the momentary BATTERY CHECK position. Null meter pointer should deflect to the beginning of green band.
- (63) Set dc power source from 22 to 28 Vdc in 4 or more steps while observing null meter for any change in null indication (zero and span change). Any change should not require that the POUNDS switch reading be changed by more than 50 pounds to obtain NULL. If unobtainable, refer to paragraph 4-36.

NOTE

Bench alignment of an Aircraft Weighing Kit checks for proper function and ability to be calibrated only. The Aircraft Weighing Kit must be calibrated using a deadweight machine before it is returned to service.

END OF TASK

SECTION VI - PREPARATION FOR STORAGE OR SHIPMENT

4-59. PREPARATION FOR STORAGE.

4-59

The Aircraft Weighing Kit may be stored using normal procedures. General instructions are provided in TM 1-1500-204-23 (Series). The case is moisture- and dust-proof when the lid is closed and secured.

4-60. PREPARATION FOR SHIPMENT.

4-60

The Aircraft Weighing Kit may be reshipped using normal electronic equipment shipping procedures.

APPENDIX A REFERENCES

A-1. Dictionaries of Terms and Abbreviations

- AR310-25 Dictionary of United States Army Terms
- AR310-50 Authorized Abbreviations and Brevity Codes

A-2. Publication Indexes

- DAPAM25-30 Consolidated Index of Army Publications and Blank Forms
Blank Forms

A-3. Logistics and Storage

- TM 743-200-1 Storage and Materials Handling

A-4. Maintenance of Supplies and Equipment

- AR 750-1 Army Material Maintenance Concepts and Policies
- DA PAM 738-751 Functional Users Manual for The Army Maintenance Management
System-Aviation (TAMMS-A).
- TM 43-0139 Painting Operations Instructions for Field Use

A-5. Other Publications

- AR 420-90 Fire Prevention and Protection
- AR 55-38 Reporting of Transportation Discrepancies in Shipments
- AR 700-58 Packaging Improvement Report
- DA PAM 310-13 Military Publications Posting and Filing
- FM-21-11 First Aid for Soldiers
- TB 43-180 Calibration and Repair Requirements for the Maintenance of
Army Materiel
- TB 55-6670-201-50 Calibration Procedure for Aircraft Weighing Kit
- TM 750-244-2 Procedures for the Destruction of Electronic Material to Prevent Enemy Use
- TM 55-1500-342-23 Army Aviation Maintenance Engineering Manual, Weight and Balance
- TB MED 223 Respiratory Protection (Hazardous Solvents)
- TM 1-1500-204-23(Series) General Aircraft Maintenance Manual

APPENDIX B

MAINTENANCE ALLOCATION CHART

SECTION I. INTRODUCTION

B-1. MAINTENANCE ALLOCATION CHART.

a. This Maintenance Allocation Chart (MAC) assigns maintenance functions in accordance with the Three Levels of Maintenance concept for army aircraft. These maintenance levels, Aviation Unit Maintenance (AVUM), Aviation Intermediate Maintenance (AVIM) and Depot Maintenance, are depicted on the MAC as:

AVUM which corresponds to the O code in the Repair Parts and Special Tools List (RPSTL).

AVIM which corresponds to the F code in the Repair Parts and Special Tools List (RPSTL).

DEPOT which corresponds to the D code in the Repair Parts and Special Tools List (RPSTL).

b. The maintenance to be performed below depot and in the field is described as follows:

(1) AVIATION UNIT MAINTENANCE (AVUM) . AVUM activities will be staffed and equipped to perform high frequency "On-Equipment" maintenance tasks required to retain or return equipment to a serviceable condition. The maintenance capability of the AVUM will be governed by the MAC and limited by the amount and complexity of support equipment, facilities required, and number of spaces and critical skills available. The range and quantity of authorized spare modules/components will be consistent with the mobility requirements dictated by the air mobility concept. (Assignment of maintenance tasks to divisional company size aviation units will consider the overall maintenance capability of the division, the requirement to conserve personnel and equipment resources and air mobility requirements.)

(a) COMPANY SIZE AVIATION UNITS. Perform those tasks which consist primarily of preventive maintenance and maintenance repair and replacement functions associated with sustaining a high level of equipment operational readiness. Perform maintenance inspections and servicing to include daily, intermediate, periodic and special inspections as authorized by the MAC or higher headquarters. Identify the cause of equipment/system malfunctions using applicable technical manual troubleshooting instructions, Built-In Test Equipment (BITE), installed instruments, or easy to use Test Measurement and Diagnostic Equipment (TMDE). Replace worn or damaged modules/components which do not require complex adjustments or system alignment and which can be removed and installed with available skills, tools and equipment. Perform operational and continuity checks and make minor repairs. Perform servicing, functional adjustments, and minor repair/replacement. Evacuate unserviceable modules/components and end items beyond the repair capability of AVUM to the supporting AVIM.

(b) LESS THAN COMPANY SIZE AVIATION UNITS. Aviation elements organic to brigade, group, battalion headquarters and detachment size units are normally small and have less than ten aircraft assigned. Maintenance tasks performed by the

aircraft crew chief or assigned aircraft repairman will normally be limited to preventive maintenance, inspections, servicing, spot painting, stop drilling, minor adjustments, module/component fault diagnosis and replacement of selected modules/components. Repair functions will normally be accomplished by the supporting AVIM unit.

(2) AVIATION INTERMEDIATE MAINTENANCE (AVIM). AVIM provides mobile, responsive "One Stop" maintenance support. (Maintenance functions which are not conducive to sustaining air mobility will be assigned to depot maintenance.) Performs all maintenance functions authorized to be done at AVUM. Repair of equipment for return to user will emphasize support or operational readiness requirements. Authorized maintenance includes replacement and repair of modules/components and end items which can be accomplished efficiently with available skills, tools, and equipment. Establishes the Direct Exchange (DX) program for AVUM units by repairing selected items for return to stock when such repairs cannot be accomplished at the AVUM level. Inspects, troubleshoots, tests, diagnoses, repairs, adjusts, calibrates, and aligns system modules/components. Module component disassembly and repair will support the DX program and will normally be limited to tasks requiring cleaning and the replacement of seals, fittings and items of common hardware. Unserviceable repairable modules/components and end items which are beyond the capability of AVIM to repair will be evacuated to Depot Maintenance. This level will perform special inspections which exceed AVUM capability. Provides quick response maintenance support, on-the-job training, and technical assistance through the use of mobile maintenance contact teams. Maintains authorized operational readiness float. Provides collections and classification services for serviceable/unserviceable material. Operates a cannibalization activity in accordance with AR 750-1. (The aircraft maintenance company within the maintenance battalion of a division will perform AVUM functions consistent with air mobility requirements and conservation of personnel and equipment resources. Additional intermediate maintenance support will be provided by the supporting non-divisional AVIM unit.)

B-2 . USE OF THE MAINTENANCE ALLOCATION CHART.

a. The MAC assigns maintenance functions to the lowest level of maintenance based on past experience and the following considerations:

- (1) Skills available.
- (2) Time required.
- (3) Tools and test equipment required and/or available.

b. Only the lowest level of maintenance authorized to perform a maintenance function is indicated. If the lowest level of maintenance cannot perform all tasks of any single maintenance function (e.g., test, repair), then the higher maintenance level(s) that can accomplish additional tasks will also be indicated. The levels are as follows:

- O - Aviation Unit Maintenance
- F - Aviation Intermediate Maintenance
- D - Depot

c. A maintenance function assigned to a maintenance level will automatically be authorized to be performed at any higher maintenance level.

d. A maintenance function that cannot be performed at the assigned level of maintenance for any reason may be evacuated to the next higher maintenance organization. Higher maintenance levels will perform the maintenance functions of lower maintenance levels when required or directed by the appropriate commander.

e. The assignment of a maintenance function will not be construed as authorization to carry the associated repair parts in stock. Authority to requisition, stock, or otherwise secure necessary repair parts will be as specified in the repair parts and special tools list appendix.

f. Normally there will be no deviation from the assigned level of maintenance. In cases of operational necessity, maintenance functions assigned to a maintenance level may, on a one-time basis and at the request of the lower maintenance level, be specifically authorized by the maintenance officer of the level of maintenance to which the function is assigned. The special tools, equipment, etc., required by the lower level of maintenance to perform this function will be furnished by the maintenance level to which the function is assigned. This transfer of a maintenance function to a lower maintenance level does not relieve the higher maintenance level of the responsibility of the function. The higher level of maintenance has the authority to determine:

(1) If the lower level is capable of performing the work .

(2) If the lower level will require assistance or technical supervision and on-site inspection.

(3) If the authorization will be granted.

g. Organizational through depot maintenance of the U.S. Army Electronics Command equipment will be performed by designated U.S. Army Electronics Command personnel.

h. Changes to the MAC will be based on continuing evaluation and analysis by responsible technical personnel and on reports received from field activities.

B-3. DEFINITIONS.

a. INSPECT. To determine serviceability of an item by comparing its physical, mechanical and electrical characteristics with established standards.

b. TEST. To verify serviceability and detect incipient failure by measuring the mechanical or electrical characteristics of an item and comparing those characteristics with prescribed standards.

c. SERVICE. To clean, to preserve, to charge, and to add fuel, lubricants, cooling agents and air.

d. ADJUST. To rectify to the extent necessary to bring into proper operating range.

e. ALIGN. To adjust specified variable elements of an item to bring to optimum performance.

f. CALIBRATE. To make a comparison of two or more instruments one of which is a certified standard traceable to the National Bureau of Standards (NBS), to detect/adjust for any discrepancy in the accuracy of the unit under test.

g. INSTALL. To set up for use in an operational environment such as an emplacement, site or vehicle.

TM 55-6670-201-13&P

h. REPLACE . To replace unserviceable items with serviceable assemblies, sub-assemblies or parts.

i. REPAIR. To restore an item to serviceable condition through correction of a specific failure or unserviceable condition. This includes, but is not limited to, inspection, cleaning, preserving, adjusting, replacing, welding, riveting, and strengthening.

j. OVERHAUL. To restore an item to a completely serviceable condition as prescribed by maintenance serviceability standards prepared and published for the specific item to be overhauled.

k. REBUILD. To restore an item to a standard as nearly as possible to the original or new condition in appearance, performance and life expectancy. This is accomplished through the maintenance technique of complete disassembly of the item, inspection of all parts or components, repair or replacement of worn or unserviceable elements (items) using original manufacturing tolerances and specifications, and subsequent reassembly of the item.

B-4. FUNCTIONAL GROUPS. Standard functional groupings are not considered feasible for aviation ground support equipment due to variation and complexity. Therefore, variations to functional groupings may occur.

B-5. MAINTENANCE CATEGORIES AND WORK TIMES. The maintenance categories (levels) AVUM, AVIM, and DEPOT are listed on the Maintenance Allocation Chart with individual columns that indicate the work times for maintenance functions at each maintenance level. Work time presentations such as 0.1 indicate the average time it requires a maintenance level to perform a specified maintenance function. If a work time has not been established, the columnar presentation shall indicate "-.-". Maintenance levels higher than the level of maintenance indicated are authorized to perform the indicated function.

B-6. TOOLS AND TEST EQUIPMENT. Common tool sets (not individual tools), special tools, test and support equipment required to perform maintenance functions are listed with a reference number to permit cross-referencing to column 5 in the MAC. In addition, the maintenance category authorized to use the device is listed along with the item National Stock Number (NSN) and, if applicable, the tool number to aid in identifying the tool/device.

SECTION II. MAINTENANCE ALLOCATION CHART

AIRCRAFT WEIGHING KIT
NSN 6670-00-148-9395

(1) Group Number	(2) Component/Assembly	(3) Maintenance Function	(4) Maintenance Category AVUM AVIM		(5) Tools & Equipment	(6) Remarks
00	Aircraft Weighing Kit	Inspect Test Repair Check Test Align Calibrate	0.2	-	(1) or (2)	
			0.5	-	(1) or (2)	
				4.0*	(1) or (2)	
			0.5	-	(1) or (2)	
				1.5*	(1) or (2)	
				3.0*	(1) or (2)	
				5.0*	(1) or (2)	
01	Accessory Kit	Inspect Replace Service	0.2	-	(1) or (2)	
			2.0	-	(1) or (2)	
			0.3	-	(1) or (2)	
02	Electronic Weighing Indicator	Inspect Repair Check Test	0.2	-	(1) or (2)	
				5.0*	(1) or (2)	
			0.5	-	(1) or (2)	
				1.5*	(1) or (2)	
	Indicator Cover	Inspect Remove Install Check	0.1	-	(1) or (2)	
			0.2	-	(1) or (2)	
			0.2	-	(1) or (2)	
			0.5	-	(1) or (2)	
	Toggle Switch	Inspect Remove Replace Check	0.2	-	(1) or (2)	
				0.3*	(1) or (2)	
				0.3*	(1) or (2)	
			0.5	-	(1) or (2)	
	Fuses	Inspect Replace Check	0.4	-	(1) or (2)	
			0.3	-	(1) or (2)	
			0.5	-	(1) or (2)	
	Null Meter	Inspect Remove Replace Check	0.2	-	(1) or (2)	
				0.5*	(1) or (2)	
				0.5*	(1) or (2)	
			0.5	-	(1) or (2)	
	Power Receptacles	Inspect Replace Check		0.6*	(1) or (2)	
				1.0*	(1) or (2)	
			0.5	-	(1) or (2)	

AIRCRAFT WEIGHING KIT
 NSN 6670-00-148-9395

(1) Group Number	(2) Component/Assembly	(3) Maintenance Function	(4) Maintenance Category AVUM AVIM	(5) Tools & Equipment	(6) Remarks
02	Terminal Board	Inspect Remove Replace Check	0.2* 1.0* 1.0* 0.5	(1) or (2)	
	Rotary Switch S101	Inspect Remove Replace Align Calibrate	1.0* 0.5* 2.0* 3.0* 5.0*	(1) or (2) (1) or (2) and (5)	
	Zero Set Control	Inspect Remove Replace Align Calibrate	0.2* 0.5* 0.5* 3.0* 5.0*	(1) or (2) (1) or (2) and (5)	
	Thumbwheel Switch	Inspect Remove Replace Align Calibrate	0.5* 0.6* 0.6* 3.0* 5.0*	(1) or (2)	
	Indicator Housing	Inspect Remove Install Test	0.2* 0.8* 1.0* 1.5*	(1) or (2)	
	Baffle, RFI Shield, (Load cells) EMI Filter	Inspect Remove Install Align Calibrate	0.2* 0.2* 0.3* 3.0* 5.0*	(1) or (2)	
	Fuseholder	Inspect Remove Replace Test	0.2* 1.0* 1.4* 1.5*	(1) or (2)	

AIRCRAFT WEIGHING KIT
 NSN 6670-00-148-9395

(1) Group Number	(2) Component/Ass embly	(3) Maintenance Function	(4) Maintenance Category AVUM AVIM		(5) Tools & Equipment	(6) Remarks
02	Transformer Assembly T101	Inspect Remove Replace Align Calibrate	0.2* 0.6* 0.7* 0.3* 5.0*	(1) or (2)		
	P/C Connector	Inspect Remove Replace Align Calibrate	0.2* 3.0* 4.0* 3.0* 5.0*	(1) or (2)		
	Baffle, RFI Shield (power), Filters FL3, FL4, and FL5	Inspect Remove / Install Replace Check	0.5 0.5 0.5	(1) or (2)		
	Circuit Card Components	Inspect Remove One Component Replace Align Calibrate	0.5* 3.0* 3.0* 5.0*	(1) or (2)		
03	Power Cables ac/dc	Inspect Replace Check	0.2 0.2 0.5	(3)		
	Load Cell Cables	Inspect Replace Align Calibrate	1.0* 2.5 3.0* 5.0	(1) or (2) (4) (1) or (2) and (5)		
04	Circuit Card Assy, Amplifier/Oscil- lator	Inspect Remove Install Align Calibrate	0.5* 1.0* 1.0* 3.0* 5.0*	(1) or (2)		

*Note: To be performed by CRC.

TM55-6670-201-13&P
SECTION III. TOOL AND TEST EQUIPMENT REQUIREMENTS
AIRCRAFT WEIGHING KIT

TOOLS OR TEST EQUIPMENT REFERENCE CODE	MAINTENANCE CATEGORY	NOMENCLATURE	NATIONAL/NATO STOCK NUMBER	TOOL NUMBER
1	AVUM	VAN,AN-GSM 286/287	6695-01-081-0960	--
2	AVIM	TOOL KIT: 35H CALIBRATION KIT	6695-01-081-0705	--
3	AVUM	TOOL KIT: ELECTRICAL REPAIRER: ARMY AIRCRAFT	5180-00-323-4915	--
4	AVIM	PLIERS, HEYCO	5120-00-929-2036	29
5	AVIM	SIMULATOR, LOAD CELL REVERE MODEL R941 OR EQUIVALENT	-	--

APPENDIX C

REPAIR PARTS AND SPECIAL TOOLS LIST

(INCLUDING DEPOT MAINTENANCE REPAIR PARTS AND SPECIAL TOOLS)

(Current as of June 8, 1984)

SECTION I. INTRODUCTION

C-1. SCOPE.

This appendix lists spares and repair parts required for performance of Aviation Unit Maintenance (AVUM) and Aviation Intermediate Maintenance (AVIM) and Depot Maintenance of the Aircraft Weighing Kit, Type A/S 37M-1. It authorized the requisitioning and issue of spares and repair parts as indicated by the source and maintenance codes.

C-2. GENERAL .

This Repair Parts and Special Tools List is divided into the following sections:

- a. Section II. Repair Parts List. A list of spares and repair parts authorized for use in the performance of maintenance. The list also includes parts which must be removed for replacement of the authorized parts, in figure and item number sequence.
- b. Section III. Tool and Test Equipment Requirements.
- c. Section IV. National Stock Number and Part Number Index. A list, in National Item Identification Number (NIIN) sequence of all National Stock Numbers (NSN) appearing in the listings, followed by a list, in alphanumeric sequence, of all part numbers appearing in the listings. National stock numbers and part numbers are cross-referenced to each illustration figure and item number appearance.

C-3. EXPLANATION OF COLUMNS.

- a. Illustration. This column is divided as follows:

- (1) Figure Number. Indicates the figure number of the illustration on which the item is shown.

- (2) Item Number. The number used to identify each item called out in the illustration.

- b. Source, Maintenance and Recoverability Codes (SMR).

- (1) Source Code. Source codes indicate the manner, of acquiring support items for maintenance, repair or overhaul of end items. Source codes are entered in the first and second positions of the Uniform SMR Code format as follows:

Code	Definition
PA	Item procured and stocked for anticipated or known usage.
PB	Item procured and stocked for insurance purpose because essentiality dictates that a minimum quantity be available in the supply systems.
PC	Item procured and stocked and which otherwise would be coded PA except that" it is deteriorative in nature.
PD	Support item, excluding support equipment, procured for initial issue or outfitting and stocked only for subsequent or additional initial issues or outfittings. Not subject to automatic replenishment.
PE	Support equipment procured and stocked for initial issue or outfitting to specified maintenance repair activities.
PF	Support equipment which will not be stocked but which will be centrally procured on demand.
PG	Item procured and stocked to provide for sustained support for life of the equipment. It is applied to an item peculiar to the equipment which, because of probable discontinuance or shutdown of production facilities , would prove uneconomical to reproduce at a later time.
KD	An item of a depot overhaul/repair kit and not purchased separately. Depot kit defined as a kit that provides items required at the time of overhaul or repair.
KF	An item of a maintenance kit and not purchased separately. Maintenance kit defined as a kit that provides an item that can be replaced at Aviation Unit or Aviation Intermediate levels of maintenance.
KB	Item included in both a depot overhaul/repair kit and a maintenance kit procured on demand.
MO	Item to be manufactured or fabricated at the Aviation Unit Maintenance level.
MF	Item to be manufactured or fabricated at the Aviation Intermediate maintenance level.
MD	Item to be manufactured or fabricated at the depot maintenance level.
AO	Items to be assembled at the Aviation Unit Maintenance level.

Code	Definition
AF	Item to be assembled at the Aviation Intermediate Maintenance level.
AD	Item to be assembled at depot maintenance level.
XA	Item is not procured or stocked because the requirements for the item will result in the replacement of the next higher assembly.
XB	Item is not procured or stocked. If not available through salvage, requisition.
XD	A support item that is not stocked. When required, item will be procured through normal supply channels.
XC	Installation drawing, diagram, instruction sheet, field service drawing, that is identified by manufacturer's part number.

NOTE

Cannibalization or salvage may be used as a source of supply for any items source coded above except those coded XA and aircraft support items as restricted by AR 700-42.

(2) Maintenance Code. Maintenance codes are assigned to indicate the levels of maintenance authorized for USE and REPAIR support items. The maintenance codes are entered in the third and fourth positions of the Uniform SMR Code format as follows:

(a) The maintenance code entered in the third position will indicate the lowest maintenance level authorized to remove, replace and use the support item. The maintenance code entered in the third position will indicate one of the following levels of maintenance:

Code	Application/Explanation
0	Support item is removed, replaced, used at the Aviation Unit Maintenance level.
F	Support item is removed, replaced, used at the Aviation Intermediate Maintenance level.
D	Support items that are removed, replaced, used at depot, mobile depot, specialized repair activity only.

(b) The maintenance code entered in the fourth position indicates whether the item is to be repaired and identifies the lowest maintenance level with the capability to perform complete repair (i.e., all authorized maintenance functions). This position will contain one of the following maintenance codes:

Code	Application/Explanation
0	The lowest maintenance level capable of complete repair of the support item is the Aviation Unit Maintenance level.
F	The lowest maintenance level capable of complete repair of the support item is the Aviation Intermediate Maintenance level.
D	The lowest maintenance level capable of complete repair of the support item is the depot level.
L	Repair restricted to designated specialized repair activity.
Z	Nonreparable. No repair is authorized.
B	No repair is authorized. The item may be reconditioned by adjusting, lubricating, etc., at the user level. No parts or special tools are procured for the maintenance of this item.

(3) Recoverability Code. Recoverability codes are assigned to support items to indicate the disposition action on unserviceable items. The recoverability code is entered in the fifth position of the Uniform SMR Code format as follows:

Code	Definition
Z	Nonreparable item. When unserviceable, condemn and dispose at the level indicated in position 3.
0	Reparable item. When not reparable, condemn and dispose at Aviation Unit Maintenance level.
F	Reparable item. When uneconomically reparable, condemn and dispose at the Aviation Intermediate Maintenance level.
D	Reparable item. When beyond lower level repair capability, return to depot. Condemnation and disposal not authorized below depot level.
L	Reparable item. Repair, condemnation and disposal not authorized below depot/specialized repair activity level.
A	Item requires special handling or condemnation procedures because of specific reasons (i.e., precious metal content, high dollar value, critical material or hazardous materials). Refer to appropriate manuals/directives for specific instructions.

c. National Stock Number. Indicates the National stock number assigned to the Item and which will be used for requisitioning purposes.

d. Federal Supply Code for Manufacturer (FSCM). The FSCM is a 5-digit numeric code listed in SB 708-42 which is used to identify the manufacturer, distributor, or Government agency, etc.

NOTE

When a stock numbered item is requisitioned, the item received may have a different part number than the part being replaced.

e. Part Number. Indicates the primary number used by the manufacturer (individual, company, firm, corporation, or Government activity), which controls the design and characteristics of the item by means of its engineering drawings, specifications standards and inspection requirements, to identify an item or range of items.

f. Description. Indicates the Federal item name and, if required, a minimum description to identify the item. Items that are included in kits and sets are listed below the name of the kit or set with the quantity of each item in the kit or set indicated in the quantity incorporated in unit column. In the Special Tools List, the initial basis of issue (BOI) appears as the last line in the entry for each special tool, special TMDE, and other special support equipment. When density of equipments supported exceeds density spread indicated in the basis of issue, the total authorization is increased accordingly.

g. Unit of Measure (U/M). Indicates the standard of the basic quantity of the listed item as used in performing the actual maintenance function. This measure is expressed by a two-character alphabetical abbreviation (e.g., ea, in., pr, etc.). When the unit of measure differs from the unit of issue, the lowest unit of issue that will satisfy the required units of measure will be requisitioned.

h. Quantity Incorporated in Unit. Indicates the quantity of the item used in the breakout shown on the illustration figure, which is prepared for a functional group, subfunctional group, or an assembly. A "V" appearing in this column in lieu of a quantity indicates that no specific quantity is applicable (e.g., shims, spacers, etc.).

C-4. SPECIAL INFORMATION.

In the parts list, some items are indented to show that they are a component or components of the item under which they are indented.

C-5. HOW TO LOCATE REPAIR PARTS.

a. When National Stock Number or Part Number is Unknown.

(1) First. Find the illustration covering the assembly to which the item belongs.

(2) Second. Identify the item on the illustration and note the illustration figure and item number of the item.

(3) Third. Using the Repair Parts Listing, find the figure and item number noted on the illustration.

b. When National Stock Number or Part Number is known.

(1) First. Using the Index of National Stock Numbers and Part Numbers, find the pertinent National stock number or part number. This index is in ascending NIIN sequence followed by a list of part numbers in alphanumeric sequence, cross-referenced to the illustration figure number and item number.

(2) Second. After finding the figure and item number, locate the figure and item number in the repair parts list.

C-6. ABBREVIATIONS.

Not applicable.

SECTION II. REPAIR PARTS LIST

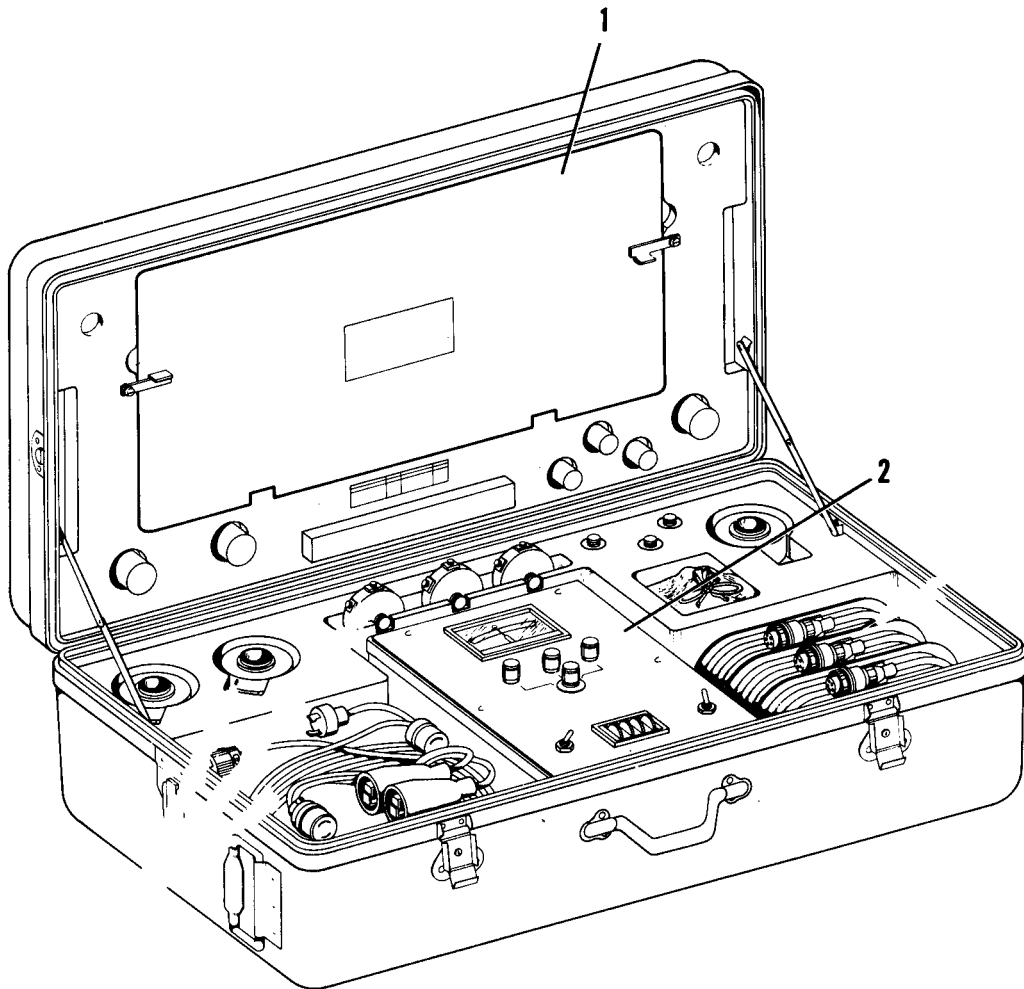

Figure C-1 . Aircraft Weighing Kit A/S 37M-1

(1) ILLUSTRATION (A) FIG NO	(2) (B) ITEM NO	(3) SMR CODE	(4) NATIONAL STOCK NUMBER	(5) PART NUMBER	(6) DESCRIPTION	(7) USABLE ON CODE	(8) QTY INC IN UNIT
					GROUP 00 - AIRCRAFT WEIGHING KIT		
C-1	1	XCOZZ	140430-00	50625	ACCESSORY KIT	EA	1
C-1	2	XCFDD	155692-09	50625	INDICATOR, ELECTRONIC WEIGHING	EA	1

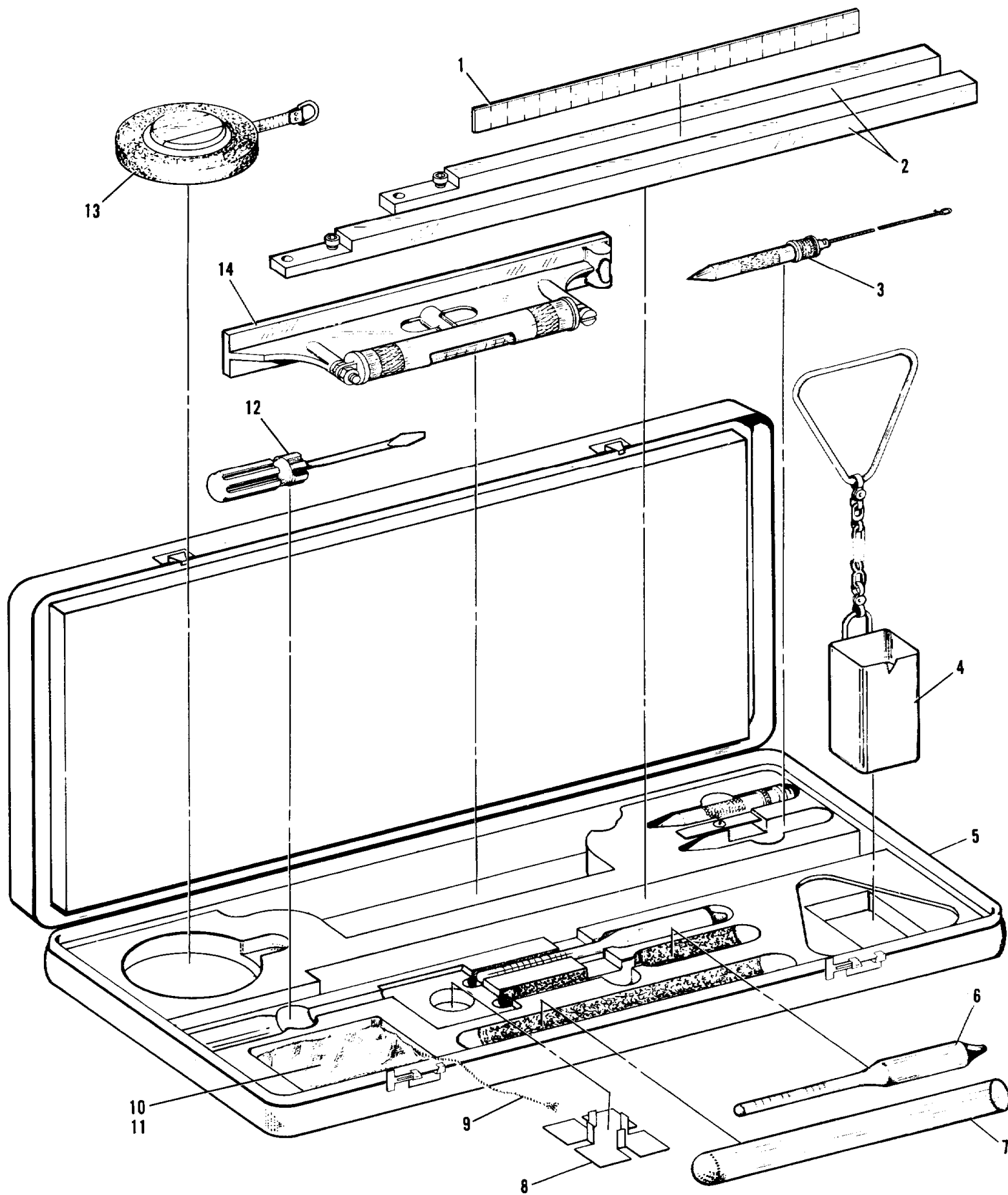

Figure C-2. Accessory Kit

(1) ILLUSTRATION (A) FIG NO	(2) (B) ITEM NO	(3) SMR CODE	(3) NATIONAL STOCK NUMBER	(4) PART NUMBER	(5) FSCM	(6) DESCRIPTION	(7) USABLE ON CODE	(8) QTY INC IN UNIT
						GROUP 01 - ACCESSORY KIT		
C-2	1	PBOZZ	6670-00-890-2478	320069-00	50625	RULE, 12-INCH	EA	1
C-2	2	XBOZZ		145997-00	50625	BAR ASSEMBLY, LEVELING	EA	1
C-2	3	XBOZZ		102102-00	50625	BOB ASSEMBLY, PLUMB	EA	2
C-2	4	PBOZZ	6670-00-833-2774	102104-00	50625	DIPPER ASSEMBLY, FUEL	EA	1
C-2	5	XDOZZ		157908-01	50625	CASE ASSEMBLY	EA	1
C-2	6	PBOZZ	6630-00-657-0018	102113-01	50625	HYDROMETER	EA	2
C-2	7	XDOZZ		302112-00	50625	JAR, HYDROMETER	EA	1
C-2	8	XDOZZ		102264-00	50625	BASE, HYDROMETER	EA	1
C-2	9	PBOZZ	4020-00-133-6526	600398-00	50625	LINE, CHALK	EA	1
C-2	10	XDOZZ		320051-00	50625	BAG, CLOTH	EA	1
C-2	11	XDOZZ		320049-00	50625	CHALK	EA	V
C-2	12	XDOZZ		320134-00	50625	SCREWDRIVER, STANDARD	EA	1
C-2	13	XBOZZ	5210-00-935-5142	140283-00	50625	TAPE, STEEL	EA	1
C-2	14	PBOZZ	5210-00-223-9607	320131-00	50625	LEVEL, 12-INCH	EA	1

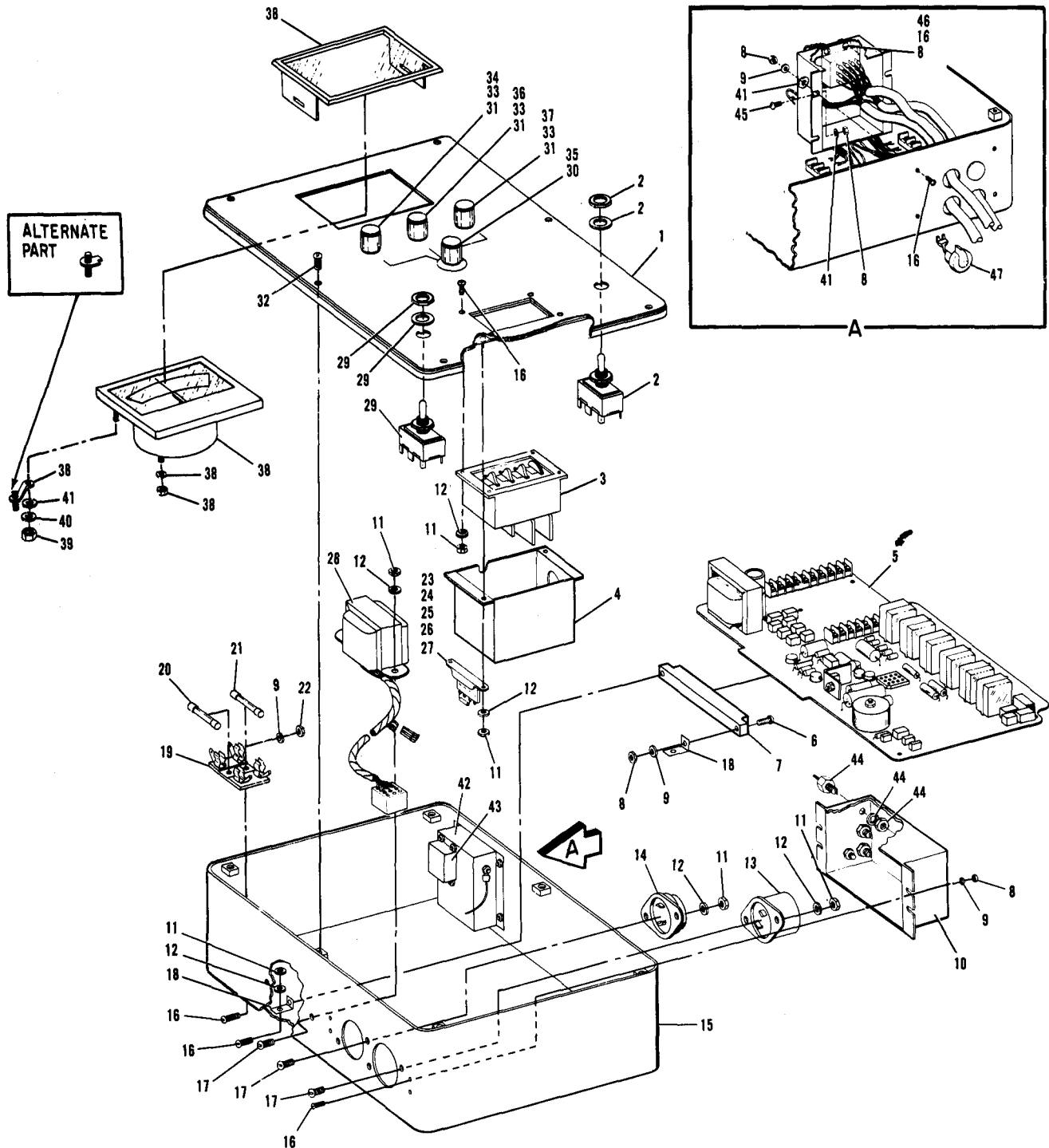
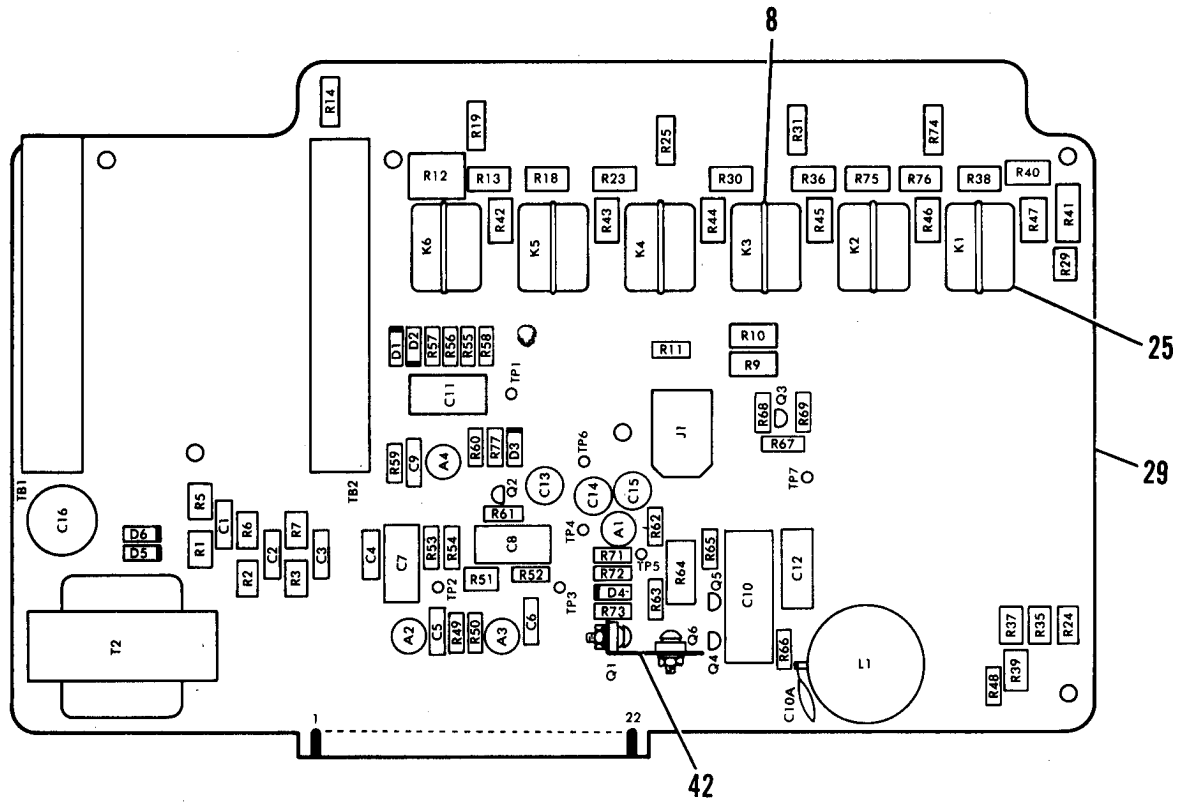

Figure C-3. Electronic Weighing Indicator

(1) ILLUSTRATION (A) FIG NO	(2) (B) ITEM NO	(3) SMR CODE	(4) NATIONAL STOCK NUMBER	(5) PART NUMBER	(6) FSCM DESCRIPTION	(7) USABLE ON CODE U/M	(8) QTY INC IN UNIT
					GROUP 02 - ELECTRONIC WEIGHING INDICATOR		
C-3	--	XDFFF	155692-09	50625	INDICATOR, ELECTRONIC WEIGHING	EA	1
C-3	1	XAFZZ	155698-04	50625	COVER ASSEMBLY, INDICATOR	EA	1
C-3	2	XDFZZ	325717-04	50625	SWITCH, DPDT, ON-OFF-MOM ON (S103)	EA	1
C-3	3	PBFZZ	6625-00-306-9439	328958-01	50625 SWITCH, THUMBWHEEL (S104) (KELVIN-VARLEY VOLTAGE DIVIDER CKT)	EA	1
C-3	4	XDFZZ	155782-00	50625	SHIELD, SWITCH	EA	1
C-3	5	XDFFF	155691-04	50625	CIRCUIT CARD ASSEMBLY, AMPLIFIER/ OSCILLATOR (REFER TO FIG. C-4)	EA	1
C-3	6	XDFZZ	326958-03	50625	SCREW, RD-HD, NO. 4-40 X 1/2	EA	2
C-3	7	XDFZZ	327398-22	50625	CONNECTOR, P/C (P101)	EA	1
C-3	8	XDFZZ	328728-02	50625	NUT, HEX, NO. 4-40	EA	15
C-3	9	XDFZZ	328546-02	50625	WASHER, LOCK, NO. 4	EA	14
C-3	10	XDFZZ	162011-00	50625	BAFFLE, RFI SHIELD (POWER)	EA	1
C-3	11	XDFZZ	328728-03	50625	NUT, HEX, NO. 6-32	EA	6
C-3	12	XDFZZ	328546-04	50625	WASHER, LOCK NO. 6	EA	8
C-3	13	PBFZZ	5935-00-178-8069	328459-01	50625 CONNECTOR, MALE, 2-WIRE, FLUSH BASE (J104)	EA	1
C-3	14	XDFZZ	320568-01	50625	CONNECTOR, MALE, 3-WIRE, FLUSH BASE (J103)	EA	1
C-3	15	XDFZZ	155696-01	50625	HOUSING ASSEMBLY, INDICATOR	EA	1
C-3	16	XDFZZ	326958-13	50625	SCREW, RD-HD, NO. 4-40 X 1/4	EA	14
C-3	17	XDFZZ	327584-09	50625	SCREW, PAN-HD, NO. 6-32 X 3/8	EA	6
C-3	18	XDFZZ	153957-00	50625	BRACKET, CONNECTOR	EA	2
C-3	19	XDFZZ	304080-02	50625	FUSEHOLDER	EA	1
C-3	20	XDOZZ	320055-02	50625	FUSE, 1/4A (F101)	EA	1
C-3	21	XDOZZ	320055-03	50625	FUSE, 1/2A (F102)	EA	1
C-3	22	XDFZZ	320553-00	50625	NUT, HEX, SMALL-PATTERN, NO. 6-32	EA	2
C-3	23	XDFZZ	327379-04	50625	TERMINAL BOARD (TB101)	EA	1
C-3	24	XDFZZ	327279-02	50625	DIODE, 1N4002 (D101)	EA	1
C-3	25	XDFZZ	328598-01	50625	RESISTOR, 1 MEGOHM, MC60D, 1% (R105,R108)	EA	2
C-3	26	XDFZZ	600306-37	50625	RESISTOR, 340K OHMS, RN60C, 1% (R106)	EA	1
C-3	27	XDFZZ	600305-34	50625	RESISTOR, 4.7K OHMS, 1/4W, 5% (R107)	EA	1
C-3	28	XDFZZ	155702-01	50625	TRANSFORMER ASSEMBLY, OSCILLATOR (T101)	EA	1
C-3	29	XDFZZ	325717-07	50625	SWITCH, DPDT, ON-OFF-ON (S102)	EA	1
C-3	30	XDFZZ	328974-04	50625	SWITCH, ROTARY (S101)	EA	1
C-3	31	XDFZZ	327626-03	50625	ZERO SET CONTROL, 2K OHMS, HT (R101,R102,R103)	EA	3
C-3	32	XDFZZ	328952-02	50625	SCREW, CAPTIVE, NO. 8-32	EA	6
C-3	33	XDFZZ	328956-05	50625	KNOB, CONTROL	EA	3
C-3	34	XDFZZ	328969-01	50625	INSERT, KNOB, RED	EA	1
C-3	35	XDFZZ	328957-01	50625	KNOB, POINTER	EA	1
C-3	36	XDFZZ	328969-02	50625	INSERT, KNOB, YELLOW	EA	1
C-3	37	XDFZZ	328969-03	50625	INSERT, KNOB, BLUE	EA	1
C-3	38	PBFZZ	6625-00-308-7716	328955-00	50625 METER, BEZEL, AND CLAMP	EA	1
C-3	39	XDFZZ	328728-02	50625	NUT, HEX, NO. 4-40	EA	2
C-3	40	XDFZZ	328902-01	50625	WASHER, LOCK, NO. 4	EA	2
C-3	41	XDFZZ	328630-19	50625	WASHER, FLAT, NO. 4	EA	9
C-3	42	XDFZZ	162012-02	50625	BAFFLE, RFI SHIELD (LOAD CELLS)	EA	1
C-3	43	XDFZZ	330121-02	50625	FILTER (FL1)	EA	1
C-3	44	XDFZZ	330243-00	50625	FILTER (FL3, FL4, FL5)	EA	3
C-3	45	XDFZZ	326958-11	50625	SCREW, RD-HD, NO. 4-40 X 3/8	EA	1
C-3	46	XDFZZ	600471-04	50625	WASHER, FLAT. NO. 4	EA	3
C-3	47	XDFZZ	326255-04	50625	BUSHING, STRAIN RELIEF	EA	3



LEGEND									
REF DES	ITEM NO.	REF DES	ITEM NO.	REF DES	ITEM NO.	REF DES	ITEM NO.	REF DES	ITEM NO.
A1	7	D4	44	R9	19	R43	14	R65	15
A2	7	D5	53	R10	19	R44	14	R66	15
A3	7	D6	53	R11	18	R45	14	R67	28
A4	7	K1	9	R12	10	R46	14	R68	15
C1	4	K2	9	R13	13	R47	14	R69	27
C2	4	K3	9	R14	2	R48	32	R71	43
C3	4	K4	9	R18	17	R49	46	R72	43
C5	48	K5	9	R19	2	R50	43	R73	45
C6	48	K6	9	R23	17	R51	50	R74	2
C7	11	L1	33	R24	30	R52	46	R75	21
C8	11	Q1	38	R25	2	R53	51	R76	21
C9	4	Q2	49	R29	24	R54	51	R77	16
C10	35	Q3	26	R30	17	R55	12	T2	54
C11	11	Q4	36	R31	2	R56	6	TB1	1
C12	34	Q5	36	R35	31	R57	6	TB2	1
C13	40	Q6	38	R36	20	R58	12	XX1	25
C14	40	R1	52	R37	24	R59	3	XX2	25
C15	40	R2	52	R38	22	R60	15	XX3	25
C16	55	R3	52	R39	31	R61	47	XX4	25
D1	5	R5	50	R40	23	R62	39	XX5	25
D2	5	R6	50	R41	10	R63	41	XX6	25
D3	5	R7	50	R42	14	R64	37		

Figure C-4. Circuit Card Assembly, Amplifier/Oscillator

(1) ILLUSTRATION (A) FIG NO	(2) (B) ITEM NO	(3) SMR CODE	(4) NATIONAL STOCK NUMBER	(5) PART NUMBER	(6) FSCM DESCRIPTION	(7) USABLE ON CODE U/M	(8) QTY INC IN UNIT
GROUP 03 - AMPLIFIER/OSCILLATOR PRINTED CIRCUIT CARD							
C-4	1	XDFZZ	328720-09	50625	TERMINAL BLOCK (TB1,TB2)	EA	2
C-4	2	XDFZZ	328776-05	50625	RESISTOR, VARIABLE, 10 OHMS (R14,R19,R25,R31,R74)	EA	5
C-4	3	XDFZZ	600306-13	50625	RESISTOR, FIXED, 499K OHMS, RN 60 (R59)	EA	1
C-4	4	XDFZZ	327693-01	50625	CAPACITOR, -001 UF, 100V (C1,C2,C3,C9)	EA	4
C-4	5	XDFZZ	327917-00	50625	DIODE, 1N3064 (D1,D2,D3)	EA	3
C-4	6	XDFZZ	600305-10	50625	RESISTOR, 1.5K OHMS, 1/4W, 5% (R56,R57)	EA	2
C-4	7	XDFZZ	327933-00	50625	AMPLIFIER, U5B7741393 (A1,A2,A3,A4)	EA	4
C-4	8	XDFZZ	328153-01	50625	RETAINER, RELAY	EA	6
C-4	9	XDFZZ	328183-01	50625	RELAY (K1,K2,K3,K4,K5,K6)	EA	6
C-4	10	XDFZZ	328954-02	50625	RESISTOR, 81K OHMS, 0.1% (R12,R41)	EA	2
C-4	11	XDFZZ	327693-46	50625	CAPACITOR, 0.33 UF, 50V (C7,C8,C11)	EA	3
C-4	12	XDFZZ	600305-23	50625	RESISTOR, 27K OHMS, 1/4W, 5% (R55,R58)	EA	2
C-4	13	XDFZZ	328282-10	50625	RESISTOR, 179.5 OHMS, 0.1% (R13)	EA	1
C-4	14	XDFZZ	328282-27	50625	RESISTOR, 980.0 OHMS, 0.02% (R42,R43, R44,R45,R46,R47)	EA	6
C-4	15	XDFZZ	600305-03	50625	RESISTOR, 10K OHMS, 1/4W, 5% (R60,R65, R66,R68)	EA	4
C-4	16	XDFZZ	600305-05	50625	RESISTOR, 1 MEGOHM, 1/4W, 5% (R77)	EA	1
C-4	17	XDFZZ	328282-00	50625	RESISTOR, 174.5 OHMS, 0.1% (R18,R23,R30)	EA	3
C-4	18	XDFZZ	600306-36	50625	RESISTOR, 453 OHMS, RN60C (R11)	EA	1
C-4	19	XDFZZ	600248-18	50625	RESISTOR, 16K OHMS, 1% (R9,R10)	EA	2
C-4	20	XDFZZ	328282-08	50625	RESISTOR, 177.0 OHMS, 0.1% (R36)	EA	1
C-4	21	XDFZZ	328282-17	50625	RESISTOR, 5.0 OHMS, 0.1% (R75,R76)	EA	2
C-4	22	XDFZZ	328282-11	50625	RESISTOR, 182.0 OHMS, 0.1% (R38)	EA	1
C-4	23	XDFZZ	328383-18	50625	RESISTOR, 621.0 OHMS, 0.1% (R40)	EA	1
C-4	24	XDFZZ	328776-07	50625	RESISTOR, VARIABLE, 100 OHMS (R29,R37)	EA	2
C-4	25	XDFZZ	328152-03	50625	SOCKET, RELAY (XK1,XK2,XK3,XK4,XK5,XK6)	EA	6
C-4	26	XDFZZ	327417-01	50625	TRANSISTOR, 2N4125 (Q3)	EA	1
C-4	27	XDFZZ	600305-04	50625	RESISTOR, 100K OHMS, 1/4W, 5% (R69)	EA	1
C-4	28	XDFZZ	600305-26	50625	RESISTOR, 330K OHMS, 1/4W, 5% (R67)	EA	1
C-4	29	XDFZZ	600282-00	50625	BOARD - P/C, AMPLIFIER/OSCILLATOR	EA	1
C-4	30	XDFZZ	328282-05	50625	RESISTOR, 1406.0 OHMS, 0.1% (R24)	EA	1
C-4	31	XDFZZ	328282-15	50625	RESISTOR, 2000.0 OHMS, 0.1% (R35,R39)	EA	2
C-4	32	XDFZZ	600305-99	50625	RESISTOR, SOT, 1/4W, 5% (R48)	EA	1
C-4	33	XDFZZ	327627-00	50625	INDUCTOR-TOROID, 400MH (L1)	EA	1
C-4	34	XDFZZ	327693-45	50625	CAPACITOR, 0.22 UF, 50V (C12)	EA	1
C-4	35	XDFZZ	327693-19	50625	CAPACITOR, 1.0 UF, 100V (C10)	EA	1
C-4	36	XDFZZ	328191-00	50625	TRANSISTOR, 2N5088 (Q4,Q5)	EA	2
C-4	37	XDFZZ	327827-00	50625	RESISTOR, 150 OHMS, 2W, 5% (R64)	EA	1
C-4	38	XDFZZ	327197-01	50625	TRANSISTOR, 2N4921 (Q1,Q6)	EA	2
C-4	39	XDFZZ	600305-39	50625	RESISTOR, 5.6 OHMS, 1/4W, 5% (R62)	EA	1
C-4	40	XDFZZ	329890-68	50625	CAPACITOR, 50 UF, 35V (C13,C14,C15)	EA	3
C-4	41	XDFZZ	600305-13	50625	RESISTOR, 1.8 OHMS, 1/4W, 5% (R63)	EA	1
C-4	42	XDFZZ	155911-00	50625	HEATSINK	EA	1

(1) ILLUSTRATION (A) FIG NO	(2) (B) ITEM NO	(3) SMR CODE	(4) NATIONAL STOCK NUMBER	(5) PART NUMBER	(6) FSCM DESCRIPTION	(7) USABLE ON CODE	(8) QTY INC IN UNIT
C-4	43	XDFZZ	600306-29	50625	RESISTOR, 1K OHMS, RN60C, 1% (R50,R71,R72)	EA	3
C-4	44	XDFZZ	328279-13	50625	DIODE, 1N5250 (D4)	EA	1
C-4	45	XDFZZ	600305-07	50625	RESISTOR, 1.2K OHMS, 1/4W, 5% (R73)	EA	1
C-4	46	XDFZZ	600306-30	50625	RESISTOR, 100K OHMS, RN60C, 1% (R49,R52)	EA	2
C-4	47	XDFZZ	600305-02	50625	RESISTOR, 1K OHMS, 1/4W, 5% (R61)	EA	1
C-4	48	XDFZZ	327693-05	50625	CAPACITOR, 0.0047 UF, 100V (C5,C6)	EA	2
C-4	49	XDFZZ	328190-00	50625	TRANSISTOR, FIELD-EFFECT, 2N5457 (Q2)	EA	1
C-4	50	XDFZZ	328776-02	50625	RESISTOR, VARIABLE, 5K OHMS (R5,R6,R7,R51)	EA	4
C-4	51	XDFZZ	600306-16	50625	RESISTOR, 10K OHMS, RN60C, 1% (R53,R54)	EA	2
C-4	52	XDFZZ	328776-01	50625	RESISTOR, VARIABLE, 50K OHMS (R1,R2,R3)	EA	3
C-4	53	XDFZZ	327279-02	50625	DIODE, 1N4002 (D5,D6)	EA	2
C-4	54	XDFZZ	327921-00	50625	TRANSFORMER POWER (T2)	EA	1
C-4	55	XDFZZ	329890-86	50625	CAPACITOR, 500 UF, 50V (C16)	EA	1

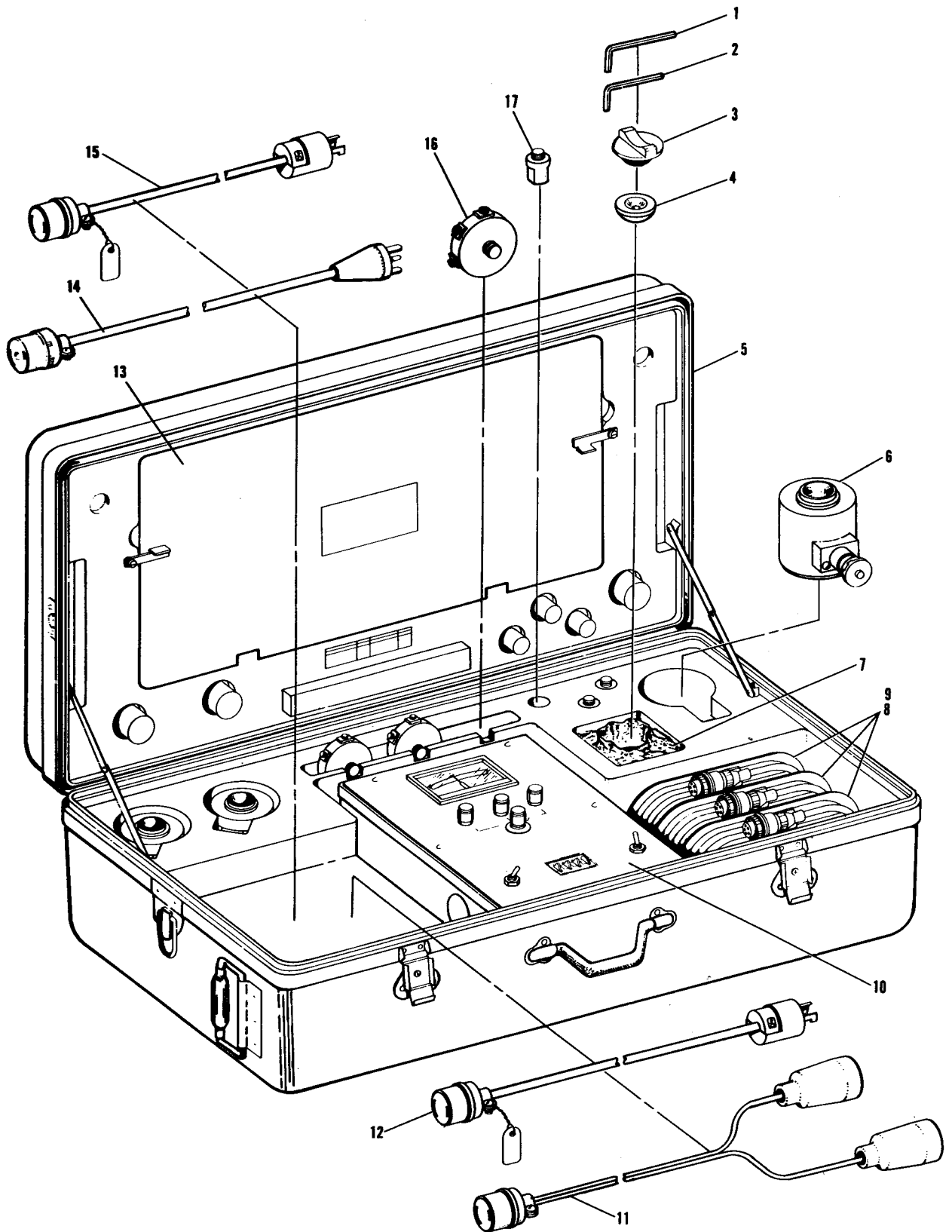

Figure C-5. Cable Assemblies, Cells, Weighing Accessories

(1) ILLUSTRATION (A) FIG NO	(2) (B) ITEM NO	(3) SMR CODE	(4) NATIONAL STOCK NUMBER	(5) PART NUMBER	(6) DESCRIPTION FSCM	(7) USABLE ON CODE U/M	(8) QTY INC IN UNIT
GROUP 04-CABLE ASSEMBLIES, CELLS, WEIGHING ACCESSORIES							
C-5	1	XDOZZ		302115-00	50625 WRENCH	EA	1
C-5	2	XDOZZ		302115-04	50625 WRENCH	EA	1
C-5	3	XDOZZ		102110-00	50625 ADAPTER, PIPE	EA	2
C-5	4	PBOZZ	6625-00-898-5367	105832-00	50625 ADAPTER, SPHERICAL	EA	3
C-5	5	XBFDD		155802-01	50625 CASE ASSEMBLY	EA	1
C-5	6	PBFZZ	6670-00-653-9329	146170-00	50625 LOAD CELL, HERMETICALLY-SEALED, AIRCRAFT 50,000-LB CAPACITY	EA	3
C-5	7	XDOZZ		320051-00	50625 BAG, CLOTH	EA	1
C-5	8	XDOZZ		140138-00	50625 REEL ASSEMBLY	EA	3
C-5	9	XDFZZ	6670-00-064-4534	141048-01	50625 CABLE ASSEMBLY	EA	3
C-5	10	XDOZZ		155692-09	50625 INDICATOR, ELECTRONIC WEIGHING (SEE GROUP 03)	EA	1
C-5	11	XDFZZ	6150-00-134-6597	102499-01	50625 CABLE ASSEMBLY, BATTERY	EA	1
C-5	12	XDFZZ		102498-03	50625 CABLE ASSEMBLY	EA	1
C-5	13	XCOZZ		140430-00	50625 KIT, ACCESSORY (SEE GROUP 01)	EA	1
C-5	14	XDFZZ		142117-03	50625 CORD ASSEMBLY	EA	1
C-5	15	XDFZZ	6670-00-064-4489	102498-01	50625 CABLE ASSEMBLY EXTENSION	EA	1
C-5	16	PBOZZ	6670-00-833-2767	102106-00	50625 ADAPTER ASSEMBLY, RING	EA	3
C-5	17	PBOZZ	6670-00-998-3501	102108-00	50625 ADAPTER, PLUG	EA	3
SECTION III. SPECIAL TOOLS							
(1) ILLUSTRATION (A) FIG NO	(2) (B) ITEM NO	(3) SMR CODE	(4) NATIONAL STOCK NUMBER	(5) PART NUMBER	(6) DESCRIPTION FSCM	(7) USABLE ON CODE U/M	(8) QTY INC IN UNIT
C-6	1	PBFZZ	5120-00-928-2036	R-29	50625 PLIERS, HEYCO	EA	1

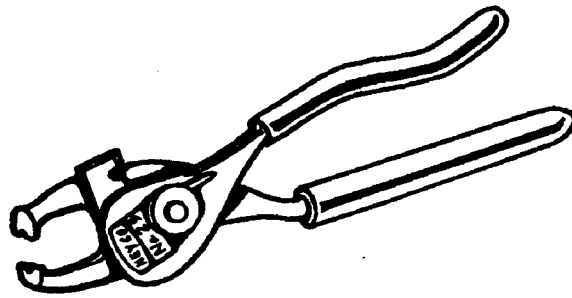

Figure C-6. Heyco R29 Pliers.

TM55-6670-201-13&P
SECTION IV. NATIONAL STOCK NUMBER AND PART NUMBER INDEX

STOCK NUMBER	FIGURE NO	ITEM NO	STOCK NUMBER	FIGURE NO	ITEM NO
4020-00-133-6526	C-2	9	6630-00-657-0018	C-2	6
5210-00-223-9607	C-2	14	6670-00-064-4489	C-5	15
5210-00-935-5142	C-2	13	6670-00-064-4534	C-5	9
5935-00-178-8069	C-3	13	6670-00-653-9329	C-5	6
6150-00-134-6597	C-5	11	6670-00-833-2767	C-5	16
6625-00-306-9439	C-3	3	6670-00-833-2774	C-2	4
6625-00-308-7716	C-3	38	6670-00-890-2478	C-2	1
6625-00-898-5367	C-5	4	6670-00-998-3501	C-5	17

PART NUMBER	FSCM	FIG NO	ITEM NO	PART NUMBER	FSCM	FIG NO	ITEM NO
102102-00	50625	C-2	3	162011-00	50625	C-3	10
102104-00	50625	C-2	4	162012-02	50625	C-3	42
102106-00	50625	C-5	16	302112-00	50625	C-2	7
102108-00	50625	C-5	3	302115-00	50625	C-5	1
102110-00	50625	C-5	3	302115-04	50625	C-5	2
102113-01	50625	C-2	6	304080-02	50625	C-3	19
102264-00	50625	C-2	8	320049-00	50625	C-2	11
102498-01	50625	C-5	15	320051-00	50625	C-2	10
102498-03	50625	C-5	12	320051-00	50625	C-5	7
102499-01	50625	C-5	11	320055-02	50625	C-3	20
105832-00	50625	C-5	4	320055-03	50625	C-3	21
140138-00	50625	C-5	8	320069-00	50625	C-2	1
140283-00	50625	C-2	13	320131-00	50625	C-2	14
140430-00	50625	C-1	1	320134-00	50625	C-2	12
140430-00	50625	C-5	13	320553-00	50625	C-3	22
141048-01	50625	C-5	9	320568-01	50625	C-3	14
141170-00	50625	C-5	6	325717-04	50625	C-3	2
142117-03	50625	C-5	14	325717-07	50625	C-3	29
145997-00	50625	C-2	2	326255-04	50625	C-3	47
153957-00	50625	C-3	18	326958-03	50625	C-3	6
155691-04	50625	C-3	5	326958-11	50625	C-3	45
155692-09	50625	C-1	2	326958-13	50625	C-3	16
155692-09	50625	C-3	--	327197-01	50625	C-4	38
155692-09	50625	C-5	10	327279-02	50625	C-3	24
155696-01	50625	C-3	15	327279-02	50625	C-4	53
155698-04	50625	C-3	1	327379-04	50625	C-3	23
155702-01	50625	C-3	28	327398-22	50625	C-3	7
155782-00	50625	C-3	4	327417-01	50625	C-4	26
155802-01	50625	C-5	5	327584-09	50625	C-3	17
155911-00	50625	C-4	42	327626-03	50625	C-3	31
157908-01	50625	C-2	5	327627-00	50625	C-4	33
				327693-01	50625	C-4	4

PART NUMBER	FSCM	FIG NO	ITEM NO	PART NUMBER	FSCM	FIG NO	ITEM NO
327693-05	50625	C-4	48	328952-02	50625	C-3	32
327693-19	50625	C-4	35	328954-02	50625	C-4	10
327693-45	50625	C-4	34	328955-00	50625	C-3	38
327693-46	50625	C-4	11	328956-05	50625	C-3	33
327827-00	50625	C-4	37	328957-01	50625	C-3	35
327917-00	50625	C-4	5	328958-01	50625	C-3	3
327921-00	50625	C-4	54	328969-01	50625	C-3	34
327933-00	50625	C-4	7	328969-02	50625	C-3	36
328152-03	50625	C-4	25	328969-03	50625	C-3	37
328153-01	50625	C-4	8	328974-04	50625	C-3	30
328183-01	50625	C-4	9	329890-68	50625	C-4	40
328190-00	50625	C-4	49	329890-86	50625	C-4	55
328191-00	50625	C-4	36	330121-02	50625	C-3	43
328279-13	50625	C-4	44	330243-00	50625	C-3	44
328282-00	50625	C-4	17	600248-18	50625	C-4	19
328282-05	50625	C-4	30	600282-00	50625	C-4	29
328282-08	50625	C-4	20	600305-02	50625	C-4	47
328282-10	50625	C-4	13	600305-03	50625	C-4	15
328282-11	50625	C-4	22	600305-04	50625	C-4	27
328282-15	50625	C-4	31	600305-05	50625	C-4	16
328282-17	50625	C-4	21	600305-07	50625	C-4	45
328282-27	50625	C-4	14	600305-10	50625	C-4	6
328383-18	50625	C-4	23	600305-13	50625	C-4	41
328459-011	50625	C-3	13	600305-23	50625	C-4	12
328546-02	50625	C-3	9	600305-26	50625	C-4	28
328546-04	50625	C-3	12	600305-34	50625	C-3	27
328598-01	50625	C-3	25	600305-39	50625	C-4	39
328630-19	50625	C-3	41	600305-99	50625	C-4	32
328720-09	50625	C-4	1	600306-13	50625	C-4	3
328728-02	50625	C-3	8	600306-16	50625	C-4	51
328728-03	50625	C-3	11	600306-29	50625	C-4	43
328776-01	50625	C-4	52	600306-30	50625	C-4	46
328776-02	50625	C-4	50	600306-36	50625	C-4	18
328776-05	50625	C-4	2	600306-37	50625	C-3	26
328776-07	50625	C-4	24	600398-00	50625	C-2	9
328902-1	50625	C-3	40	600471-04	50625	C-3	46

APPENDIX D

EXPENDABLE SUPPLIES AND MATERIALS LIST

SECTION I. INTRODUCTION

D-1. SCOPE

This appendix lists expendable supplies and materials you will need to operate and maintain the (Aircraft Weighing Kit). These items are authorized to you by CTA 50-970, Expendable Items (Except Medical, Class V, Repair Parts, and Heraldic Items).

D-2. EXPLANATION OF COLUMNS.

a. Column (1) - Item number. This number is assigned to the entry in the listing and is referenced in the narrative instructions to identify the material (e.g., "Use cleaning compound, item 5, App. D").

b. Column (2) - Level. this column identifies the lowest level of maintenance that requires the listed item.

C - Operator/Crew
O - Aviation Unit Maintenance
F - Aviation Intermediate Maintenance
D - Depot

c. column (3) - National Stock Number. This is the National stock number assigned to the item; use it to request or requisition the item.

d. column (4) - Description. Indicates the Federal item name and, if required, a description to identify the item. The last line for each item indicates the Federal Supply Code for Manufacturer (FSCM) in parentheses followed by the part number.

e. Column (5) - Unit of Measure (U/M). Indicates the measure used in performing the actual maintenance function. This measure is expressed by a two-character alphabetical abbreviation (e.g., ea, in, pr). If the unit of measure differs from the unit of issue, requisition the lowest unit of issue that will satisfy your requirements.

TM55-6670-201-13&P
SECTION II. EXPENDABLE SUPPLIES AND MATERIALS LIST

(1)	(2)	(3)	(4)	(5)
ITEM NUMBER	LEVEL	STOCK NUMBER	DESCRIPTION	U/M
1	C		ISOPROPYL ALCOHOL	AR
2	O		LOCKTITE TYPE A OR TYPE 222 GENERAL PURPOSE (-02 TUBE)	AR
3	C		CLEANING SOLVENT M-14 (JOHN B. MOORE CO.)	AR
4	O	7920-00-205-1711	CLOTH	AR
5	F		HEAT SHRINK TUBING	AR
6	F	3437-00-555-4629	SOLDER QQS-571-SN60-W-RA-P2 DIA. 0.31, 1b. ROLL	AR
7	F	7510-00-550-7126	TAPE, PRESSURE SENSITIVE, RED	AR
		7510-00-550-7125	TAPE, PRESSURE SENSITIVE, YELLOW	AR
		7510-00-550-7124	TAPE, PRESSURE SENSITIVE, BLUE	AR
8	F		CABLE TIE, TYP-23M, MIL-23190	AR

GLOSSARY

ac	- Alternating Current
AR	- Army Reference Manual
AVIM	- Aviation Intermediate Maintenance
AVUM	- Aviation Unit Maintenance
BITE	- Built-in Test Equipment
BOI	- Basis of Issue
Cps	- Cycles per Second
CG	- Center of Gravity
CRC	- Calibration Repair Center
DA PAM	- Department of the Army Pamphlet
dc	- Direct Current
DX	- Direct Exchange Program
EIR	- Equipment Improvement Recommendations
emf	- Electromotive force
EMI	- Electromagnetic Interference
FM	- Field Manual
FSCM	- Federal Supply Code for Manufacturer
GSE	- Ground Support Equipment
Hz	- Hertz; unit of alternating current frequency measurement
MAC	- Maintenance Allocation Chart
MOS	- Military Occupational Specialty
MSD	- Most Significant Digit
MTOE	- Modified Table of Organization and Equipment
NIIN	- National Item Identification Number
NSN	- National Stock Number
PMCS	- Preventive Maintenance Checks and Services
RFI	- Radio Frequency Interference
RPSTL	- Repair Parts and Special Tools List
SMR	- Source, Maintenance and Recoverability
TAMMS	- The Army Maintenance Management System
TB	- Technical Bulletin
TM	- Technical Manual
TMDE	- Test, Measurement, and Diagnostic Equipment
U/M	- Unit of Measure
Vac	- Volts Alternating Current
Vac pp	- Volts Alternating Current Peak-to-Peak
Vdc	- Volts Direct Current
mV/V	- Millivolts per Volt
LSD	- Least Significant Digit
rms	- Root Mean Square
S.O.T.	- Select On Test

ALPHABETICAL INDEX

Subject	Paragraph
A	
Ac and Dc Power Cable Inspection/Replacement (TASK 6)	3-18
Ac and Dc Power Cable Replacement (TASK 25)	4-56
Ac Power Supply Function Fault Isolation	4-18
Accessory Kit Inspection (TASK 3)	3-15
Aircraft Weighing Kit Inspection (TASK 2)	3-14
Aircraft Weighing Kit Inspection Fault Isolation	4-14
Aircraft Weighing Kit Maintenance	4-38
Aircraft Weighing Kit Performance Checks (TASK 7)	4-12
AVIM Maintenance Instructions - General	4-1
AVUM Maintenance Instructions - General	3-1
B	
Before You Operate	2-6
Bench Alignment (TASK 27)	4-58
C	
Circuit Card Assembly Amplifier Oscillator Removal/Replacement (TASK 20)	4-51
Circuit Card Assembly Components Removal/Replacement (TASK 24)	4-55
Cleaning (AVIM)	4-8
Cleaning (AVUM)	3-8
Common Tools and Equipment (AVIM)	4-3
Common Tools and Equipment (AVUM)	3-3
Connector P101 Removal/Replacement (TASK 22)	4-53
D	
Dc External Power Check Fault Isolation	4-20
Destruction of Army Material to Prevent Enemy Use	1-3
Determining Center of Gravity	2-5
Differences Between Models	1-8
E	
Equipment Characteristics, Capabilities and Features	1-6
(AVIM) Extreme Environmental Maintenance	4-10
(AVUM) Extreme Environmental Maintenance	3-10

Subject	Paragraph
F	
Functional Description	1-9
Fuseholder Removal/Replacement (TASK 19)	4-50
(AVIM) Fuse Removal/Replacement (TASK 10)	4-41
(AVUM) Fuse Removal/Replacement (TASK 5)	3-17
G	
General Description	1-10
I	
(AVIM) Indicator Cover Removal/Install (TASK 8)	4-39
(AVUM) Indicator Cover Removal/Install (TASK 4)	3-16
Indicator Housing Removal/Reinstall (TASK 17)	4-48
Indicator Inspection/Fault Isolation	4-15
L	
Load Cell Cable Removal/Replacement (TASK 26)	4-57
Location and Description of Major Components	1-7
(AVIM) Lubrication	4-9
(AVUM) Lubrication	3-9
M	
Maintenance Allocation Chart (MAC)	Appendix B
Maintenance Forms, Records, Reports	1-2
(AVIM) Maintenance Operations	4-2
(AVUM) Maintenance Operations	3-2
Maintenance Procedures - General	4-37
Minimum Amplitude Waveshape Adjustment Fault Isolation	4-26
N	
Normal Operation Conditions	2-7
Null Indication Stability (115 Vat)	4-35
Null Indication Stability (24 Vdc)	4-36
Null Meter Function Check (TASK 1)	3-12
Null Meter Removal/Replacement (TASK 11)	4-42
Null Meter Function Check Fault Isolation	4-23
O	
Operating Instructions - General	2-1
Operational Procedures	2-4
Operation Under Unusual Conditions	2-8

Subject	Paragraph
P	
(AVIM) Performance Checks	4-11
(AVUM) Performance Checks	3-11
Power Receptacles Removal/Replacement (TASK 12)	4-43
Pre-operation Procedures	2-2
(AVIM) Preparation for Shipment	4-60
(AVUM) Preparation for Shipment	3-20
(AVIM) Preparation for Storage	4-59
(AVUM) Preparation for Storage	3-19
Preparation for Storage or Shipment	1-4
Preparation for Weighing Aircraft	2-3
Preventive Maintenance Checks and Services (PMCS) - General	4-7
Principles of Operation	1-11
Power Receptacle RFI Baffle Shield/Filter Removal/Replacement (TASK 23)	4-54
R	
References	Appendix A
(AVIM) Repair Parts	4-5
(AVUM) Repair Parts	3-5
Repair Parts and Special Tools List (RPSTL)	Appendix C
Reporting Equipment Improvement Recommendations (EIR)	1-5
RFI Baffle Shield and EMI Filter Removal/Replacement (TASK 18)	4-49
Rotary Switch S101 Removal/Replacement (TASK 14)	4-45
R14 Fault Isolation, Adjustment of	4-33
R19 Fault Isolation, Adjustment of	4-32
R25 Fault Isolation, Adjustment of	4-31
R29 Fault Isolation, Adjustment of	4-28
R31 Fault Isolation, Adjustment of	4-30
R37 Fault Isolation, Adjustment of	4-27
R74 Fault Isolation, Adjustment of	4-29
S	
Scope	1-1
(AVIM) Service Upon Receipt - General	4-6
(AVUM) Service Upon Receipt - General	3-6
(AVIM) Special Tools, TMDE, and Support Equipment	4-4
(AVUM) Special Tools, TMDE, and Support Equipment	3-4
Stability of Calibration	4-34

Subject	Paragraph
T	
Terminal Board Removal/Replacement (TASK 13)	4-44
Test Point Voltage Check Fault Isolation	4-19
Thumbwheel Switch Removal/Replacement (TASK 16)	4-47
TP-4 Stable Voltage Check Fault Isolation	4-21
Transformer T101 Output Check Fault Isolation	4-25
Transformer T101 Removal/Replacement (TASK 21)	4-52
Toggle Switch Removal/Replacement (TASK 9)	4-40
(AVIM) Troubleshooting - General	4-13
(AVUM) Troubleshooting - General	3-13
Y	
Yellow Band Check Fault Isolation	4-24
Z	
Zero Set Control Removal/Replacement (TASK 15)	4-46
Zero Set Controls Fault Isolation	4-22
115-Vac Receptacle Resistance Fault Isolation	4-16
24-Vdc Receptacle Fault Isolation	4-17

By Order of the Secretary of the Army:

Official:

JOHN A. WICKHAM, JR.
General, United States Army
Chief of Staff

DONALD J. DELANDRO
Brigadier General, United States Army
The Adjutant General

DISTRIBUTION:

To be distributed in accordance with DA Form 12-31, AVIM and AVUM requirements for All Fixed Wing Aircraft and All Rotary Wing Aircraft.



THEN... JOT DOWN THE DOPE ABOUT IT ON THIS FORM, CAREFULLY TEAR IT OUT, FOLD IT AND DROP IT IN THE MAIL!

SOMETHING WRONG WITH THIS PUBLICATION?

FROM: (PRINT YOUR UNIT'S COMPLETE ADDRESS)

PFC JOHN DOE
COA, 3d ENGINEER BN
FT. LEONARD WOOD, MO 63108

DATE SENT

PUBLICATION NUMBER

TM 55-6670-201-13&P

PUBLICATION DATE

17 Jun 85

PUBLICATION TITLE

Operator's Aviation Unit, And Intermediate Maintenance Manual

BE EXACT... PIN-POINT WHERE IT IS

PAGE NO.	PARA-GRAPH	FIGURE NO.	TABLE NO.
6	2-1 a		
B1		4-3	
125	line 20		

IN THIS SPACE TELL WHAT IS WRONG AND WHAT SHOULD BE DONE ABOUT IT:

In line 6 of paragraph 2-1a the manual states the engine has 6 cylinders. The engine on my set only has 4 cylinders. Change the manual to show 4 cylinders.

Callout 16 on figure 4-3 is pointing at a bolt. In key to figure 4-3, item 16 is called a shim - Please correct one or the other.

I ordered a gasket, item 19 on figure B-16 by NSN 2 910-00-762-3001. I got a gasket but it doesn't fit. Supply says I got what I ordered, so the NSN is wrong. Please give me a good NSN

PRINTED NAME, GRADE OR TITLE, AND TELEPHONE NUMBER

JOHN DOE, PFC (268) 317-7111

SIGN HERE

JOHN DOE

TEAR ALONG PERFORATED LINE

FILL IN YOUR
UNIT'S ADDRESS

FOLD BACK

DEPARTMENT OF THE ARMY

OFFICIAL BUSINESS
PENALTY FOR PRIVATE USE \$300

POSTAGE AND FEES PAID
DEPARTMENT OF THE ARMY
DOD 314



COMMANDER
U S ARMY AVIATION SYSTEMS COMMAND
ATTN: AMSAV-MPSD
4300 GOODFELLOW BOULEVARD
ST. LOUIS, MO 63120-1798

TEAR ALONG PERFORATED LINE

RECOMMENDED CHANGES TO EQUIPMENT TECHNICAL PUBLICATIONS



THEN... JOT DOWN THE DOPE ABOUT IT ON THIS FORM. CAREFULLY TEAR IT OUT. FOLD IT AND DROP IT IN THE MAIL!

SOMETHING WRONG WITH THIS PUBLICATION?

FROM: (PRINT YOUR UNIT'S COMPLETE ADDRESS)

DATE SENT

PUBLICATION NUMBER

TM 55-6670-201-13&P

PUBLICATION DATE

17 Jun 85

PUBLICATION TITLE

Operator's Aviation Unit, And Intermediate Maintenance Manual

BE EXACT... PIN-POINT WHERE IT IS

PAGE NO.	PARA-GRAPH	FIGURE NO.	TABLE NO.
----------	------------	------------	-----------

IN THIS SPACE TELL WHAT IS WRONG AND WHAT SHOULD BE DONE ABOUT IT:

TEAR ALONG PERFORATED LINE

PRINTED NAME, GRADE OR TITLE, AND TELEPHONE NUMBER

SIGN HERE:

DA FORM 2028-2
1 JUL 79

PREVIOUS EDITIONS ARE OBSOLETE.
DRSTS-M Overprint 2, 1 Nov 80.

P.S.--IF YOUR OUTFIT WANTS TO KNOW ABOUT YOUR RECOMMENDATION MAKE A CARBON COPY OF THIS AND GIVE IT TO YOUR HEADQUARTERS.

FILL IN YOUR
UNIT'S ADDRESS

FOLD BACK

DEPARTMENT OF THE ARMY

OFFICIAL BUSINESS
PENALTY FOR PRIVATE USE \$300

POSTAGE AND FEES PAID
DEPARTMENT OF THE ARMY
DOD 314



TEAR ALONG PERFORATED LINE

COMMANDER
U S ARMY AVIATION SYSTEMS COMMAND
ATTN: AMSAV-MPSD
4300 GOODFELLOW BOULEVARD
ST. LOUIS, MO 63120-1798

RECOMMENDED CHANGES TO EQUIPMENT TECHNICAL PUBLICATIONS



THEN... JOT DOWN THE DOPE ABOUT IT ON THIS FORM, CAREFULLY TEAR IT OUT, FOLD IT AND DROP IT IN THE MAIL!

SOMETHING WRONG WITH THIS PUBLICATION?

FROM: (PRINT YOUR UNIT'S COMPLETE ADDRESS)

DATE SENT

PUBLICATION NUMBER

TM 55-6670-201-13&P

PUBLICATION DATE

17 Jun 85

PUBLICATION TITLE

Operator's Aviation Unit, And Intermediate Maintenance Manual

BE EXACT... PIN-POINT WHERE IT IS

PAGE NO.

PARA-GRAPH

FIGURE NO.

TABLE NO.

IN THIS SPACE TELL WHAT IS WRONG AND WHAT SHOULD BE DONE ABOUT IT:

TEAR ALONG PERFORATED LINE

PRINTED NAME, GRADE OR TITLE, AND TELEPHONE NUMBER

SIGN HERE:

DA FORM 2028-2
1 JUL 79

PREVIOUS EDITIONS ARE OBSOLETE.
DRSTS-M Overprint 2, 1 Nov 80.

P.S.--IF YOUR OUTFIT WANTS TO KNOW ABOUT YOUR RECOMMENDATION MAKE A CARBON COPY OF THIS AND GIVE IT TO YOUR HEADQUARTERS.

FILL IN YOUR
UNIT'S ADDRESS

FOLD BACK

DEPARTMENT OF THE ARMY

OFFICIAL BUSINESS
PENALTY FOR PRIVATE USE \$300

POSTAGE AND FEES PAID
DEPARTMENT OF THE ARMY
DOD 314



COMMANDER
U S ARMY AVIATION SYSTEMS COMMAND
ATTN: AMSAV-MPSD
4300 GOODFELLOW BOULEVARD
ST. LOUIS, MO 63120-1798

TEAR ALONG PERFORATED LINE

FILL IN YOUR
UNIT'S ADDRESS

FOLD BACK

DEPARTMENT OF THE ARMY

OFFICIAL BUSINESS
PENALTY FOR PRIVATE USE \$300

POSTAGE AND FEES PAID
DEPARTMENT OF THE ARMY
DOD 314



TEAR ALONG PERFORATED LINE

COMMANDER
U S ARMY AVIATION SYSTEMS COMMAND
ATTN: AMSAV-MPSD
4300 GOODFELLOW BOULEVARD
ST. LOUIS, MO 63120-1798

CABLE INTERCONNECTIONS			
NO.	FROM	TO	LEAD COLOR
1	P101-1	CABLE SHIELD	DRAIN WIRE
	P101-X	S104 RED DOT	RED
	P101-Y	S104 BLK DOT	BLK
	P101-12	S104 LSD SLIDER	GRN
			} GREY COVER
2	P101-A	BAFFLE STUD	BLK
	FL5	F102-1	RED
			} TWISTED PAIR
3	FL3	F101-1	RED
	P101-2	FL4	BLK
	P101-1	BAFFLE STUD	DRAIN WIRE
			} GREY COVER
4	F101-2	S102-4	RED
	S102-6	P101-3	BLK
	CABLE SHIELD	P101-1	DRAIN WIRE

COMPONENT INTERCONNECTIONS		
TO	FROM	WITH
S102-1 R105	R105 TB101-3	LEADS OF R105
S102-5 R106	R106 TB101-1	LEADS OF R106
S102-5 R107	R107 TB101-2	LEADS OF R107
TB101-1 R108	R108 TB101-3	LEADS OF R108
TB101-4 D101-AN	D101-CA S102-3	LEADS OF D101
T101-6 P101-17	P101-17 P1-4	BLUE CUT OUT LEADS OF TRANSFORMER HARNESS
T101-9 P101-S	P101-S P1-7	WHT CUT OUT LEADS OF TRANSFORMER HARNESS

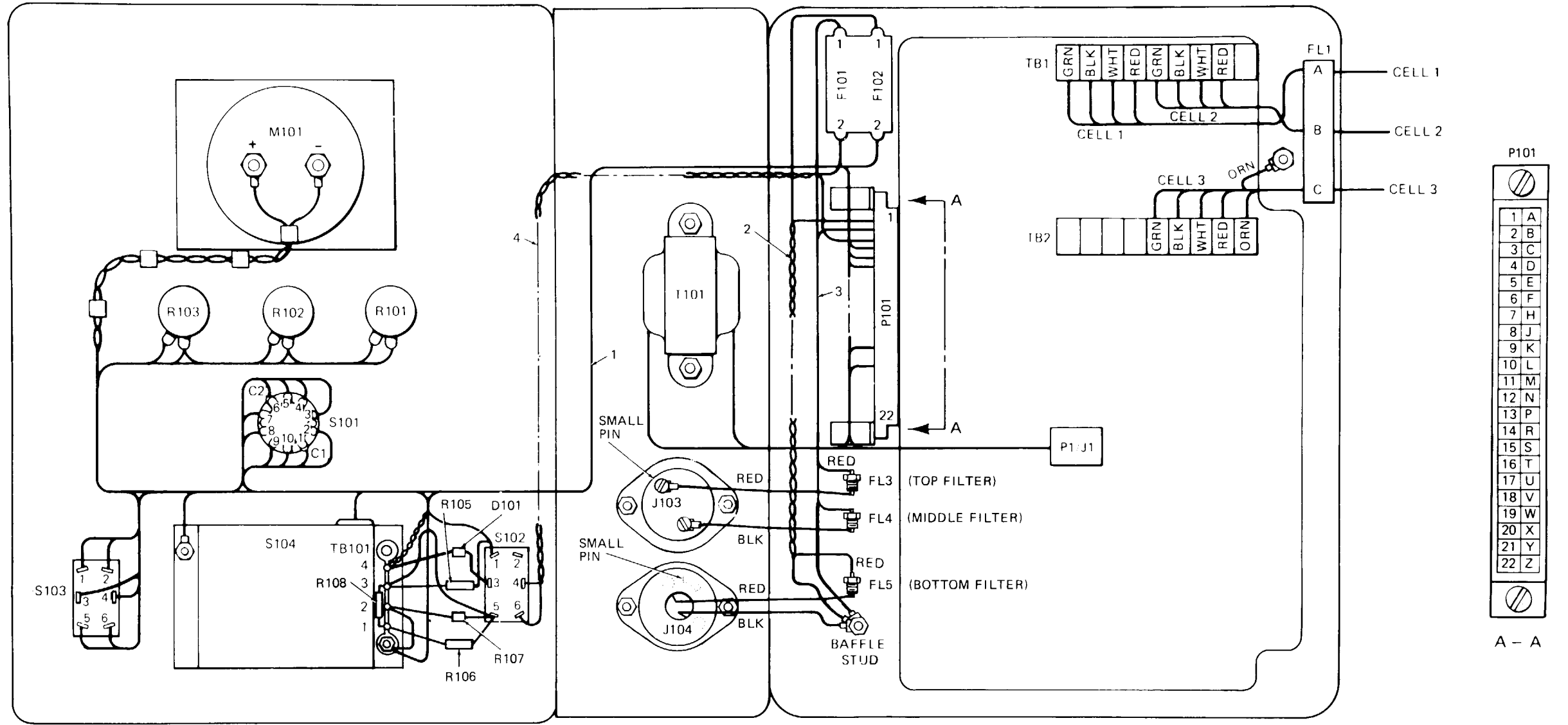

NOTES 1. CONNECTOR (P101) AND MATING CONNECTOR (J102) HAVE NUMERIC FINGERS (1-22) ON COMPONENT SIDE OF BOARD, ALPHABETIC FINGERS (A-Z, LESS G,I,O,Q) ON REVERSE SIDE OF BOARD.

2. "BAFFLE STUD" IS RFI SHIELD GROUND

3.

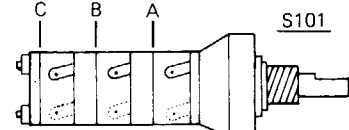

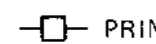
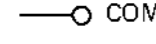
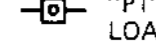

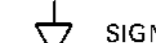

Figure FO-1. Aircraft Weighing Kit A/S 37M-1, Indicator Wiring Diagram

NOTES:

- UNLESS OTHERWISE SPECIFIED:
ALL RESISTANCES ARE IN OHMS
ALL RESISTORS ARE 1/4W, 5%
ALL CAPACITANCES ARE IN MICROFARADS
ALL CAPACITORS ARE 50V
ALL OP. AMPLIFIERS U5B7741393
- VOLTAGE READINGS FOR TP-1 THRU TP-6 TAKEN WITH TRIPLETT MODEL 630PL VOLT-OHM-MILLIAMMETER; MEASURED WITH RESPECT TO CASE GROUND.
TP-1 (NULL): EQUAL TO OR LESS THAN 0.5 VAC rms (OUTPUT)
TP-2 (F.S. INPUT FROM LOAD CELL): 0.5 VAC (Ø1) rms
TP-3 (F.S. INPUT FROM S104): 0.5 VAC (Ø2) rms
TP-4: +20 VDC
TP-5: 0 VDC
TP-6: +10 VDC

- OSCILLOSCOPE READINGS FOR TP-7 & TP-8 TAKEN WITH TEKTRONIX MODEL 565 OSCILLOSCOPE (OR EQUIVALENT OSCILLOSCOPE WITH 11 MEGOHM INPUT AND 10:1 PROBE); MEASURED WITH RESPECT TO CASE GROUND.
TP-7
20 VDC
2.0 MSEC
0.5 MSEC
TP-8 (GRN TERMINAL - TB1 OR TB2)
≈400 cps
≈3.5 V rms

4. PRINTED CIRCUIT BOARD EDGE CONNECTOR (P101) HAS NUMERIC FINGERS (1-22) ON COMPONENT SIDE OF BOARD, ALPHABETIC FINGERS (A-Z, LESS G, I, O, Q) ON REVERSE SIDE OF BOARD; NUMBER 1 AND LETTER A ARE LOCATED AT SAME END OF CONNECTOR.

- SYMBOL LEGEND
 PRINTED CIRCUIT FINGER
 COMMON TIE POINT
 "P1" SECTION FILTER (FL1) LOAD CELL TERMINATION
 "L" SECTION FILTER (FL3, FL4, FL5)
 SIGNAL COMMON
 CHASSIS GROUND

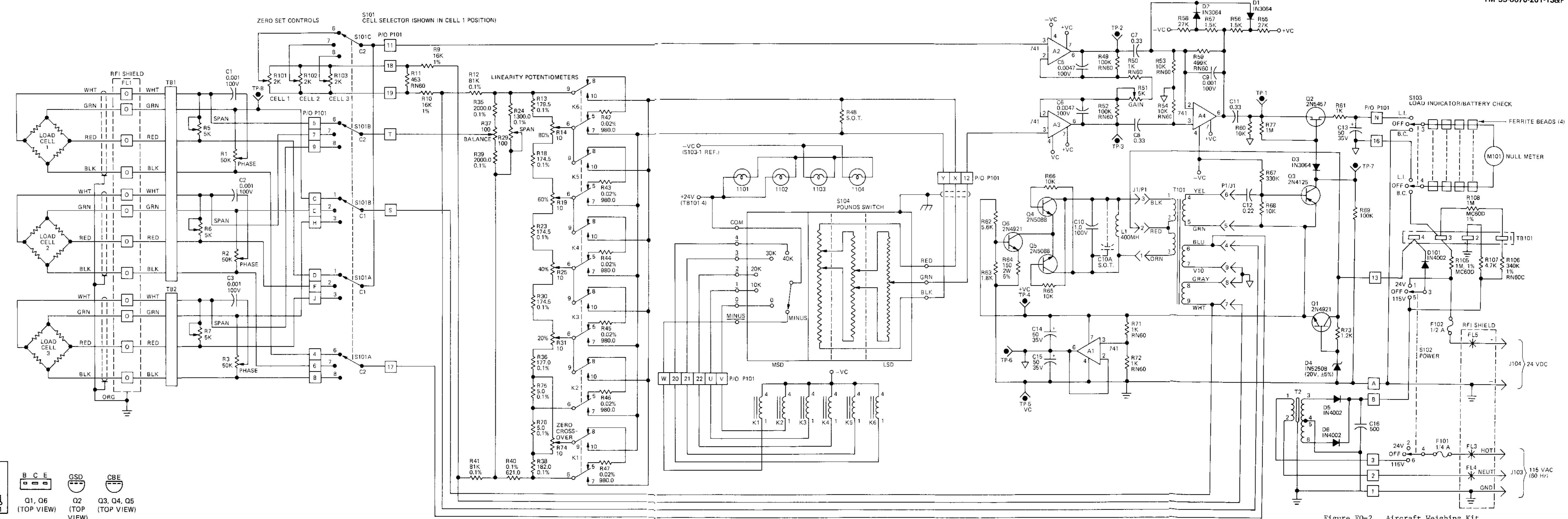
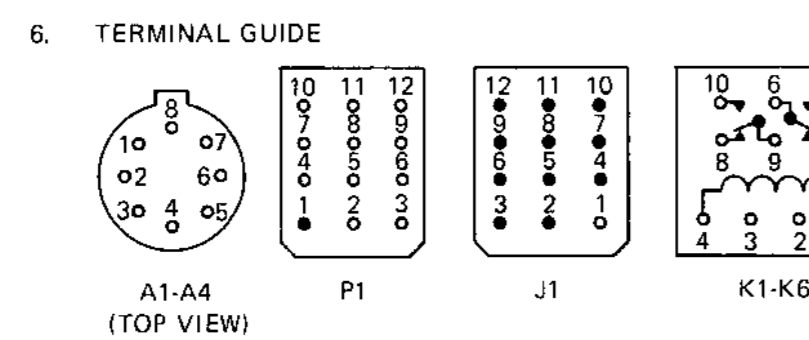

Figure FO-2. Aircraft Weighing Kit A/S 37M-1, Schematic Diagram

PART NO.	LENGTH (IN)±.250			FROM	TO	MAKE FROM	COLOR (REF.)	PART NO.	LENGTH (IN)±.250			FROM	TO	MAKE FROM	COLOR (REF.)
	A	B							A	B					
601221-00	.25	.25		P101-1	S104 SHIELD MTG, STUD	325012-00	GRN	601221-30	.25	.25		P101-W	S104MSD-9	325012-52	YEL/BRN
601221-01	.25	.25		P101-4	S101A-6	325012-04	YEL	601221-31	.25	.25		S101A-C1	S101C-C2	325012-37	WHT/BLK/VIO
601221-02	.25	.25		P101-5	S101B-6	325012-54	WHT/BLK/GRAY	601221-32	.25	.25		S101C-6	R101-SL	325012-09	ORN
601221-03	.25	.25		P101-6	S101A-7	325012-30	WHT/BLK	601221-33	.25	.25		S101C-7	R102-SL	325012-53	YEL/GRAY
601221-04	.25	.25		P101-7	S101B-7	325012-11	VIO	601221-34	.25	.25		S101C-8	R103-SL	325012-01	RED
601221-05	.25	.25		P101-8	S101A-8	325012-33	WHT/BLU	601221-35	.25	.25		R101-CCW	R102-CCW	325012-39	TAN
601221-06	.25	.25		P101-9	S101B-8	325012-32	WHT/YEL	601221-35	.25	.25		R102-CCW	R103-CCW	325012-39	TAN
601221-07	.25	.25		P101-11	S101A-C1	325012-37	WHT/BLK/VIO	601221-36	.25	.25		S103-3	M101-+	325012-43	YEL/BLK
601221-08	.25	.25		P101-13	TB101-4	325012-01	RED	601221-37	.25	.25		S103-4	M101--	325012-09	ORN
601221-09	.25	.25		TB101-3	S103-2	325012-38	WHT/ORN	601221-38	.25	.25		F102-2	S102-1	325012-01	RED
601221-10	.25	.25		P101-16	S103-6	325012-13	WHT/RED	601221-39	.25	.25		TB101-4	ILLUMINATION LAMPS	325012-01	RED
601221-11	.25	.25		P101-17	S101A-C2	325012-10	BLU	601221-40	.25	.25		S103-1	ILLUMINATION LAMPS	325012-02	BLK
601221-12	.25	.25		P101-18	R103-CCW	325012-39	TAN	601221-41	.25	.25		TB101-4	S104-MSD COMMON	325012-01	RED
601221-13	.25	.25		P101-19	R103-CW	325012-40	PINK	601221-42	.25	.25		R103-CW	R102-CW	325012-40	PINK
601221-14	.25	.25		P101-20	S104MSD-4	325012-41	YEL/BLU	601221-42	.25	.25		R102-CW	R101-CW	325012-40	PINK
601221-15	.25	.25		P101-21	S104MSD-3	325012-42	YEL/GRN	601221-43	.25	.25		FL1-A4	CELL1-GRN	325012-19	GRN
601221-16	.25	.25		P101-22	S104MSD-2	325012-43	YEL/BLK	601221-44	.25	.25		FL1-A3	CELL1-BLK	325012-15	BLK
601221-17	.25	.25		P101-A	S103-1	325012-02	BLK	601221-45	.25	.25		FL1-A2	CELL1-WHT	325012-14	WHT
601221-18	.25	.25		P101-B	A102-5	325012-13	WHT/RED	601221-46	.25	.25		FL1-A1	CELL1-RED	325012-17	RED
601221-19	.25	.25		P101-C	S101B-1	325012-08	BRN	601221-43	.25	.25		FL1-B4	CELL2-GRN	325012-19	GRN
601221-20	.25	.25		P101-D	S101A-1	325012-31	WHT/BRN	601221-44	.25	.25		FL1-B3	CELL2-BLK	325012-15	BLK
601221-21	.25	.25		P101-E	S101B-2	325012-34	WHT/VIO	601221-45	.25	.25		FL1-B2	CELL2-WHT	325012-14	WHT
601221-22	.25	.25		P101-F	S101A-2	325012-12	GRAY	601221-46	.25	.25		FL1-B1	CELL2-RED	325012-17	RED
601221-23	.25	.25		P101-H	S101B-3	325012-44	YEL/VIO	601221-43	.25	.25		FL1-C4	CELL3-GRN	325012-19	GRN
601221-24	.25	.25		P101-J	S101A-3	325012-14	WHT/GRN	601221-44	.25	.25		FL1-C3	CELL3-BLK	325012-15	BLK
601221-25	.25	.25		P101-N	S103-5	325012-47	WHT/BLK/ORN	601221-45	.25	.25		FL1-C2	CELL3-WHT	325012-14	WHT
601221-26	.25	.25		P101-S	S101B-C1	325012-48	WHT/BLK/BLU	601221-46	.25	.25		FL1-C1	CELL3-RED	325012-17	RED
601221-27	.25	.25		P101-T	S101B-C2	325012-49	WHT/BLK/RED	601221-47	.25	.25		FL4	J103-LARGE	325012-15	BLK
601221-28	.25	.25		P101-U	S104MSD-1	325012-50	YEL/ORN	601221-48	.25	.25		BAFFLE STUD	J104-LARGE	325012-15	BLK
601221-29	.25	.25		P101-V	S104MSD-0	325012-51	YEL/RED	601221-49	.25	.25		FL3	J103-SMALL	325012-17	RED
								601221-50	.25	.25		FL5	J104-SMALL	325012-17	RED
								601221-51	.25	.25		TB101-2	TS101-MTG STUD	325012-19	GRN
								601221-52	.25	.25		FL1 MTG STUD	CELL 1, 2 AND 3 COMMON	325012-29	ORN

FIGURE F0-3. AIRCRAFT WEIGHING KIT
A/S 37M-1, WIRE RUN LIST

The Metric System and Equivalents

Linear Measure

1 centimeter = 10 millimeters = .39 inch
 1 decimeter = 10 centimeters = 3.94 inches
 1 meter = 10 decimeters = 39.37 inches
 1 dekameter = 10 meters = 32.8 feet
 1 hectometer = 10 dekameters = 328.08 feet
 1 kilometer = 10 hectometers = 3,280.8 feet

Weights

1 centigram = 10 milligrams = .15 grain
 1 decigram = 10 centigrams = 1.54 grains
 1 gram = 10 decigrams = .035 ounce
 1 dekagram = 10 grams = .35 ounce
 1 hectogram = 10 dekagrams = 3.52 ounces
 1 kilogram = 10 hectograms = 2.2 pounds
 1 quintal = 100 kilograms = 220.46 pounds
 1 metric ton = 10 quintals = 1.1 short tons

Liquid Measure

1 centiliter = 10 milliliters = .34 fl. ounce
 1 deciliter = 10 centiliters = 3.38 fl. ounces
 1 liter = 10 deciliters = 33.81 fl. ounces
 1 dekaliter = 10 liters = 2.64 gallons
 1 hectoliter = 10 dekaliters = 26.42 gallons
 1 kiloliter = 10 hectoliters = 264.18 gallons

Square Measure

1 sq. centimeter = 100 sq. millimeters = .155 sq. inch
 1 sq. decimeter = 100 sq. centimeters = 15.5 sq. inches
 1 sq. meter (centare) = 100 sq. decimeters = 10.76 sq. feet
 1 sq. dekameter (are) = 100 sq. meters = 1,076.4 sq. feet
 1 sq. hectometer (hectare) = 100 sq. dekameters = 2.47 acres
 1 sq. kilometer = 100 sq. hectometers = .386 sq. mile

Cubic Measure

1 cu. centimeter = 1000 cu. millimeters = .06 cu. inch
 1 cu. decimeter = 1000 cu. centimeters = 61.02 cu. inches
 1 cu. meter = 1000 cu. decimeters = 35.31 cu. feet

Approximate Conversion Factors

To change	To	Multiply by	To change	To	Multiply by
inches	centimeters	2.540	ounce-inches	newton-meters	.007062
feet	meters	.305	centimeters	inches	.394
yards	meters	.914	meters	feet	3.280
miles	kilometers	1.609	meters	yards	1.094
square inches	square centimeters	6.451	kilometers	miles	.621
square feet	square meters	.093	square centimeters	square inches	.155
square yards	square meters	.836	square meters	square feet	10.764
square miles	square kilometers	2.590	square meters	square yards	1.196
acres	square hectometers	.405	square kilometers	square miles	.386
cubic feet	cubic meters	.028	square hectometers	acres	2.471
cubic yards	cubic meters	.765	cubic meters	cubic feet	35.315
fluid ounces	milliliters	29.573	cubic meters	cubic yards	1.308
pints	liters	.473	milliliters	fluid ounces	.034
quarts	liters	.946	liters	pints	2.113
gallons	liters	3.785	liters	quarts	1.057
ounces	grams	28.349	liters	gallons	.264
pounds	kilograms	.454	grams	ounces	.035
short tons	metric tons	.907	kilograms	pounds	2.205
pound-feet	newton-meters	1.356	metric tons	short tons	1.102
pound-inches	newton-meters	.11296			

Temperature (Exact)

°F	Fahrenheit temperature	5/9 (after subtracting 32)	Celsius temperature	°C
----	------------------------	----------------------------	---------------------	----

